

SPECIFICATIONS

Tie bar gage ring for inspection

- Specifications

P/No. : TGR- * * *
 Diameter for applied tie bar : ϕ 40 to 200
 Material : Aluminum alloy(Main body), Alloy steel (Others)

- Options

Applicable gage : UX010 (LB)
 Special indicator : TSD-591
 Torque wrench : TSR-T

- Outline dra

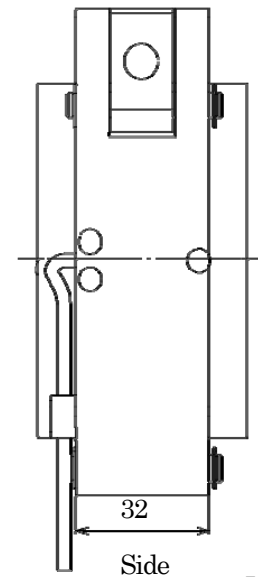
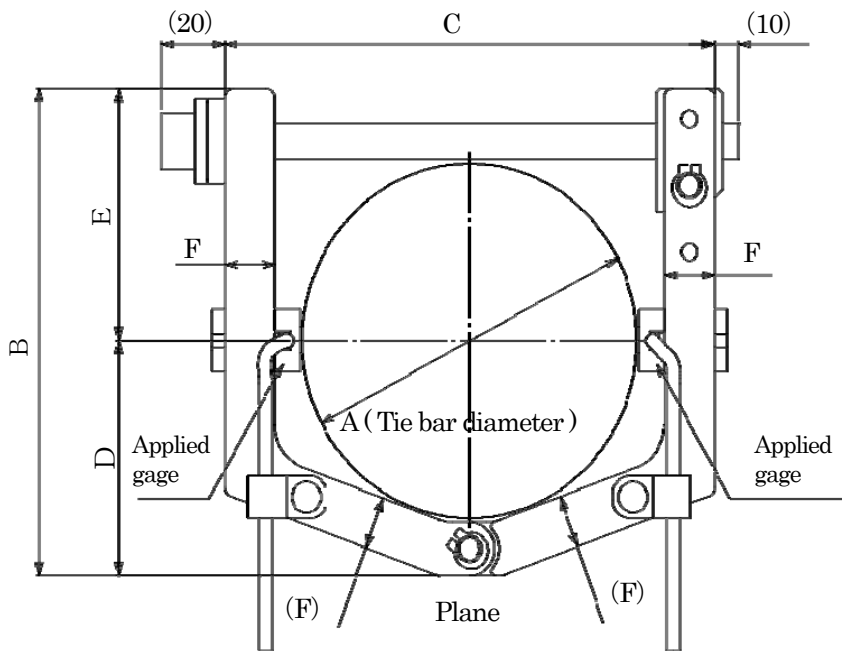

Unit:mm

Unit:mm

Outline dimension table

P/NO.	Applicable tie bar diameter	Outline dimensions					Tightening torque (cNm)	Weight (Approx.g)
		B	C	D	E	F		
TGR-(A)	A	B	C	D	E	F	140	
TGR-040	40	70	77	33	37	12		80
TGR-045	45	75	82	35.5	39.5	12		90
TGR-050	50	80	87	38	42	12		100
TGR-055	55	85	92	40.5	44.5	12		110
TGR-056	56	86	93	41	45	12		112
TGR-070	70	100	107	48	52	12		140
TGR-080	80	110	117	53	57	12		160
TGR-082	82	112	119	54	58	12		160
TGR-090	90	120	127	58	62	12		180
TGR-120	120	160	173	81	79	20		240
TGR-125	125	165	178	83.5	81.5	20		250
TGR-130	130	170	183	86	84	20		260
TGR-145	145	185	198	93.5	91.5	20		290
TGR-200	200	240	253	121	119	20		400

Specifications and outline dimensions and so on which have printed may subject to change for the purpose of improvement without notice.