

SPECIFICATIONS

Mounting attachment with slide stop mechanism CCACC010-※※B※

Spec. No. EN216111-C

1/5

Check rod method mounting attachment with slide stop mechanism for CC010-500K~50T

(※Minebea will respond to the customer's consultation about the mounting size.)

● P/No. : CCACC010-3B※
 Allowable horizontal load : ±29.42 kN {±3 tf}
 Allowable horizontal moving length : ±3 mm (without directionality), (Refer to note-2)
 Allowable lifting load : 29.42 kN {3 tf}
 Material : SS400 or equivalent (Electro less nickel plating)
 Weight : Approx. 15 kg

● P/No. : CCACC010-6B※
 Allowable horizontal load : ±58.84 kN {±6 tf}
 Allowable horizontal moving length : ±3 mm (without directionality), (Refer to note-2)
 Allowable lifting load : 58.84 kN {6 tf}
 Material : SS400 or equivalent (Electro less nickel plating)
 Weight : Approx. 20 kg

● P/No. : CCACC010-12B※
 Allowable horizontal load : ±117.7 kN {±12 tf}
 Allowable horizontal moving length : ±3 mm (without directionality), (Refer to note-2)
 Allowable lifting load : 117.7 kN {12 tf}
 Material : SS400 or equivalent (Electro less nickel plating)
 Weight : Approx. 29 kg

● P/No. : CCACC010-30B※
 Allowable horizontal load : ±294.2 kN {±30 tf}
 Allowable horizontal moving length : ±3 mm (without directionality), (Refer to note-2)
 Allowable lifting load : 294.2 kN {30 tf}
 Material : SS400 or equivalent (Electro less nickel plating)
 Weight : Approx. 55 kg

● Accessories : Guide plate 2 pieces
 Hexagon socket head cap screws (M8×L15) 8 pieces
 Instruction manual 1 piece
 Dummy load cell 1 piece
 Lift-off protection fitting 1 piece
 Washer 4 pieces
 Earth cable 1 piece

SPECIFICATIONS

Mounting attachment with slide stop mechanism CCACC010-※※B※

Spec. No.EN216111-C

2/5

● Model detail

CCACC010-※※B※

Allowable horizontal load

Loadcell Capacity

	1	2	3	4
3	500K/1T	2T/3T	5T/30T	50T
6	500K/1T	2T/3T	5T/30T	50T
12	500K/1T	2T/3T	5T/30T	50T
30	500K/1T	2T/3T	5T/30T	50T

Note* Depending on the capacity of load cell applied, the corresponding form shall differ.

When you request the installing metals, specify the capacity of load cell (P/N) together with them.

SPECIFICATIONS

Mounting attachment with slide stop mechanism CCACC010-※※B※

Spec. No. EN216111-C

3/5

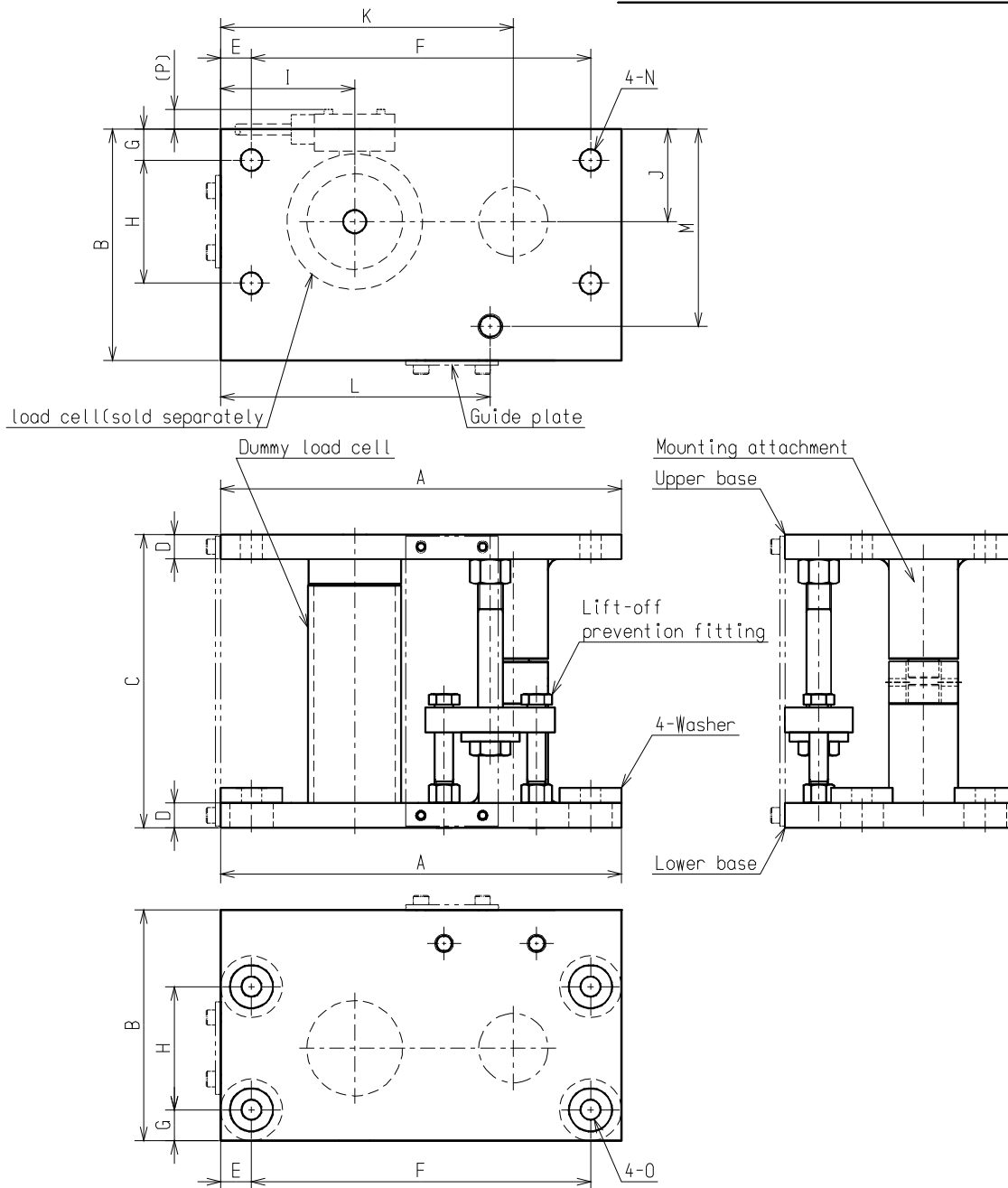

Outline dimension table (*The following is the represented example.)

Unit : mm

P/No.	A	B	C	D	E	F	G	H	I	J
CCACC010-3B※	260	150	190.5	16	20	220	20	80	87	60
CCACC010-6B※	280	180	190.5	16	25	230	25	85	90	67.5
CCACC010-12B※	300	200	196.5	19	28	244	28	90	94	73
CCACC010-30B※	350	230	214.5	28	32	286	32	100	100	82
P/No.	K	L	M	N	O	P	Washer			
CCACC010-3B※	190	175	128	φ 14	φ 28	13	Out dia. : φ 40 In dia. : φ 13 Height : 10			
CCACC010-6B※	195	140	150	φ 18	φ 32	5.5	Out dia. : φ 45 In dia. : φ 18 Height : 10			
CCACC010-12B※	204	150	165	φ 22	φ 36	-	Out dia. : φ 50 In dia. : φ 22 Height : 12			
CCACC010-30B※	226	175	190	φ 33	φ 46	-	Out dia. : φ 60 In dia. : φ 33 Height : 15			

※ Specifications and outline dimensions and so on which have printed may subject to change for the purpose of improvement.

SPECIFICATIONS

Mounting attachment with slide stop mechanism CCACC010-※※B※

Spec. No. EN216111-C

4/5

● Note

1. Please design strength of the bracket and rack where the mounting attachment with slide stop mechanism is installed to endure the load enough.
2. Please construct it deliberately because the bracket and the rack where the mounting attachment with slide stop mechanism is installed are important parts that support the load.
3. Please construct that the surface of the bracket and rack where the mounting attachment with slide stop mechanism is installed is set at the right angles to the direction of load. (The horizontal degree of the rack is within 1/2 degree. If the high accuracy is required, please set is within 1/4 degree.)
4. Please keep the jack-up space between the bracket and rack of the tank because there is the necessity for lifting the tank in adjusting the level of the tank or exchanging the load cell.
5. Please consider the drainage measures so that water should not collect when you set up the mounting attachment with slide stop mechanism in the pit.
6. Please protect cover so that neither direct sunshine, nor wind, nor rain may strike directly to the mounting attachment with slide stop mechanism in outdoor. The cover might be detached when maintaining it, and please make the cover a structure that can be detached.
7. Installed height recommends the position near the center of gravity of the tank.
8. Please set the connecting rod turning outside. (Refer to the figure below.)
9. Please note the structure when mounting attachment with slide stop mechanism is set up to consider the thermal expansion of the tank. The example of installing direction is as follows;

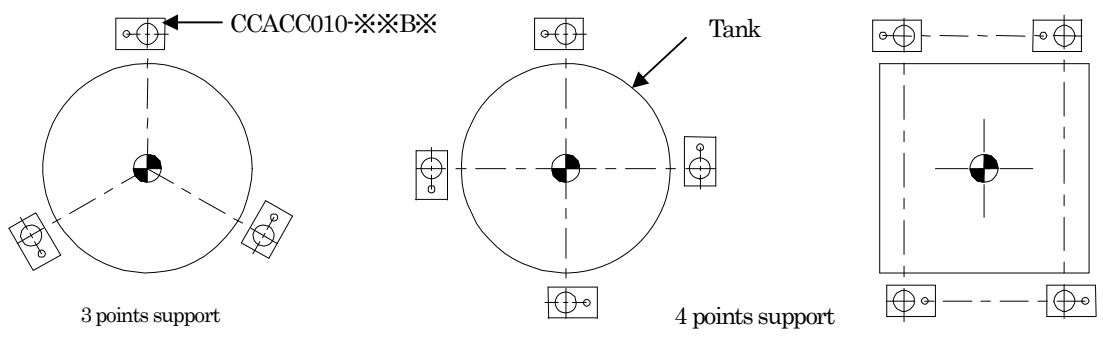

10. Please install the bolt surely in consideration of the locking when you set it up.
11. Don't weld the mounting attachment with slide stop mechanism with the structure (such as beam or bracket, etc.,) directly.
12. Don't execute the welding operation in the condition of the load cell in the mounting attachment.
Please take the earth near the welding part when executing it by all means so that the welding current should not flow to the load cell. Moreover, please remove the load cell cable from the amplifier for safety.
13. Don't cut the load cell cable. The calibration value might shift when cutting it.
14. The side lock plate on the tank side might not be able to be detached for the installation of example II of 4-points support. Please take the side lock plate on the tank side beforehand for such an installation or keep the space between tanks as it is removable.
15. Install the lower base by the attached washer.
16. The load cell must become vertical for the installation side of the mounting attachment with slide stop mechanism.

SPECIFICATIONS

Mounting attachment with slide stop
mechanism CCACC010-※※B※

Spec. No. EN216111-C

5/5

- The spot facing hole has prepared so that the load button shall be inserted to the bearing plate. Be sure to insert the load button of load cell.

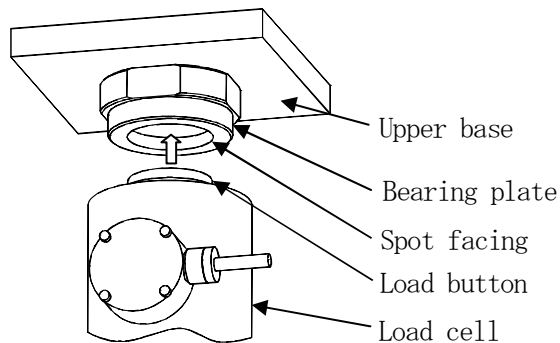

- The construction of bearing plate has made so that the bearing plate will be screwed to the upper base. This is the reason to put the shim plate between the upper base and bearing plate for the purpose of level adjustment. Use the bearing plate with fully screwed up. Never use the bearing plate with some space between the bearing plate and upper base, or never use the bearing plate instead of a jack.

