

# SPECIFICATIONS

## 1. Outline

When the cable of the strain gage applied transducer is extended, this junction box is used.

## 2. General specifications

- Parts No. B-304B-A-※ (standard product: B-304B-A-10)
- Protective construction IP67
- Applicable cable diameter  $\phi$  3 mm to  $\phi$  7 mm (Internal diameter of gasket  $\phi$  7 mm:6)  
 $\phi$  7 mm  $\phi$  11 mm (Internal diameter of gasket  $\phi$  11 mm:10)
- Materials of case ADC-12A (Aluminum die casting)
- Painting color Metallic silver
- Operating temperature range -10 °C to 70 °C
- Weight approx 800 g

## 3. Name of P/N

Name of P/N
B-304B-A-6
B-304B-A-10
B-304B-A-6-10

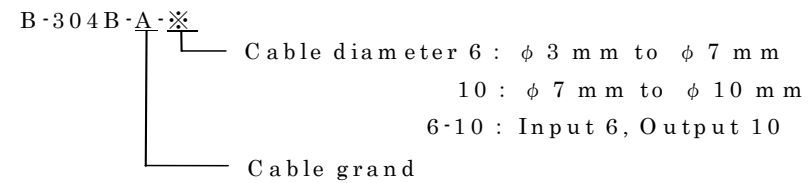

## Note)

- 1) when the instrument is installed in outdoors, be sure to locate with the upper cover upward or in the vertical direction.  
And when you install it vertically, set it in the status of drawing direction of cable grand in parallel to the ground or set it in the downward direction.
- 2) when deterioration of insulation is considered due to wide range of temperature change and dew condensation, fill the instrument with white Vaseline after cable connection is completed.  
Instead, you can use a desiccant.  
※ Specifications and outline dimensions and so on which have printed may subject to change for the purpose of improvement.

## Terminal connection

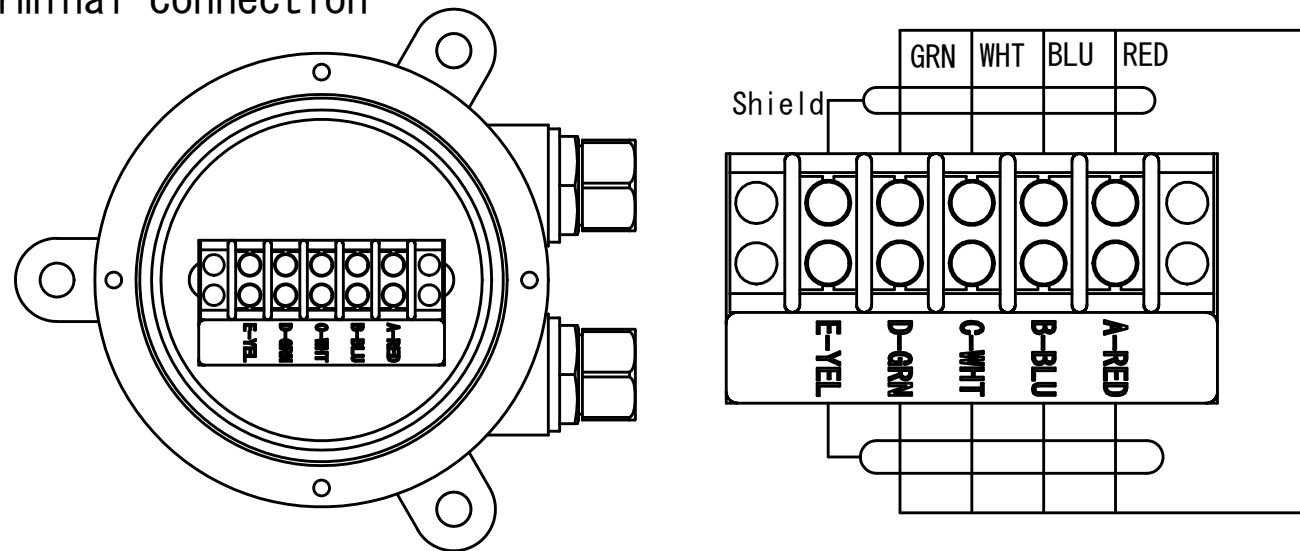

## Outline dimensions

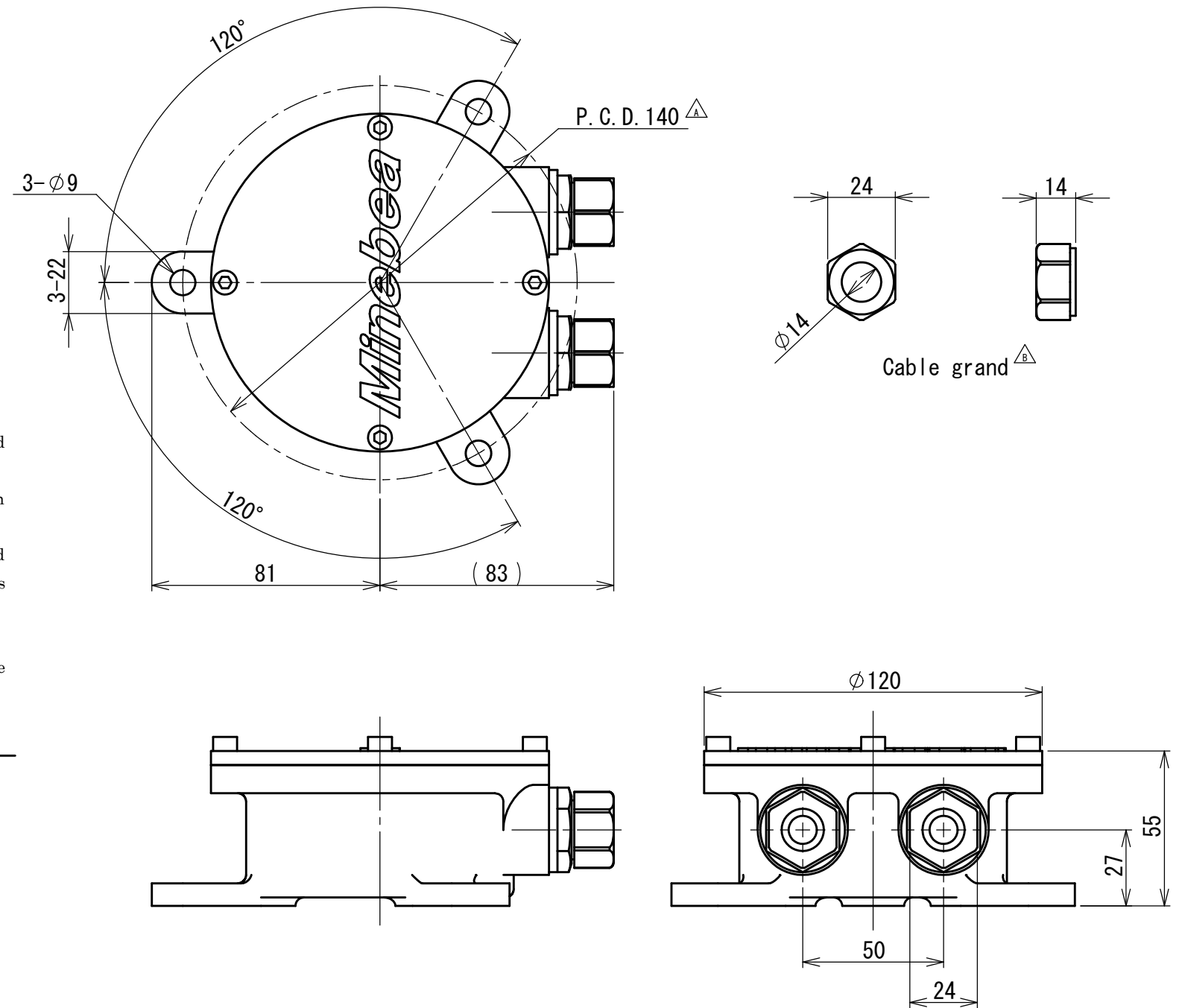

				<b>ミネベア株式会社</b> <b>MINEBEA CO., LTD.</b> 計測機器事業部			単位 UNIT mm 尺度 SCALE 1:2	材質 MATERIAL 表面粗サ SURF. ROUGH. 熱処理 HEAT TREAT. 表面処理 FINISH	作成日 DATE 2007/09/04 品名 DESCRIPTION <b>Specification drawings</b> 品番 PART NO. (MODEL NO.) B-304B-A-※ 図番 DRAWING NO. KX51912-2-ENG	葉番 SHEET 1 / 1 改訂 REV. B
B	07/09/04	FN07-01042		APPROVED	CHECKED	DRAWN	寸法公差 TOL			
A	07/07/09	FN07-01037					L ≤ 4 ±0.1 4 < L ≤ 16 ±0.2 16 < L ≤ 63 ±0.3 63 < L ≤ 250 ±0.5 250 < L ≤ 1000 ±0.8 角度 DEG ±0.5			
符号 MARK	日付 DATE	変更事由 REASON	ECN NO.	担当 ENGINEER	承認 APPROVED	能登 原 田中				