

Minebea

***DIGITAL TRANSMITTER
OPT-563B***

Quick Instruction Manual

Introduction

Thank you for purchasing OPT-563B Digital Transmitter for flange type torque transducers using optical transmission.

This instruction manual is a [quick] instruction manual primarily intended to describe the procedure for calibration by inputting numerical torque values.

For detailed instructions on how to use the OPT-563B, refer to Instruction Manual EN294-1596*.

Note that handling or operating the device incorrectly may result in malfunctions. Read the instruction manual EN294-1596* thoroughly before use for safety and optimal results.

The guaranteed accuracy when calibrating by inputting numerical torque values will be approximately 1/500 ($\pm 0.2\%$ RO).

Note also that symmetry correction cannot be adjusted using numerical input.

Keep this instruction manual in a location where it is readily accessible to end users.

Pictograms and conventions used in this manual

This manual uses the following pictograms to indicate actions to avoid at all times, aspects requiring caution, and other noteworthy matters.

Be sure to read the descriptions provided alongside these pictograms.



WARNING

This indicates circumstances in which incorrect handling may result in death or serious injury to users.

Avoid the actions described here at all times.



CAUTION

This indicates circumstances in which incorrect handling may result in injury to users or damage to property.









This indicates operating or procedural precautions or restrictions. Always read the details included here to avoid malfunctioning.

Revision History

Date	Manual No.	Revision reason (details)
2015/12	DRW. No.EN294-1723	1st issue
2016/06	DRW. No.EN294-1723-A	Due to ECN No, FN16-02057 -Deletion- Delete 'Minebea Co., Ltd. Measuring Components Business Unit' from the front cover.
2017/09	DRW. No.EN294-1723-B	Due to ECN FN17-02017 •Delete the company name in the cover page. •Delete the company name in the contents.

Contents

INTRODUCTION	I
PICTOGRAMS AND CONVENTIONS USED IN THIS MANUAL	I
REVISION HISTORY	II
CONTENTS	III
1. PART NAMES AND FUNCTIONS	5
1-1. Front Panel	5
1-2. Rear Panel.....	7
2. OPERATING INSTRUCTIONS	8
2-1.  Key	8
2-1-1. When Operated in Measurement Mode	8
2-2.  Key	8
2-2-1. When Operated in Measurement Mode	8
2-2-2. When Operated in Other Modes.....	8
2-3.  Key	8
2-3-1. When Operated in Measurement Mode	8
2-3-2. When Operated in Other Modes.....	8
2-4.  Key.....	8
2-4-1. When Operated in Measurement Mode	8
2-4-2. When Operated in Other Modes.....	9
2-5.  Key.....	9
2-5-1. When Operated in Measurement Mode	9
2-5-2. When Operated in Other Modes.....	9
2-6.  Key.....	9
2-6-1. When Operated in Measurement Mode	9
2-6-2. When Operated in Other Modes.....	9
2-7.  Key.....	9
3. CALIBRATION	10
3-1. Settings Required for Calibration.....	10

3-2. Settings to be Altered As Necessary After Calibration	10
3-3. Calibration Procedure.....	11
3-3-1. Calibration in Measurement Mode	11
3-3-2. Selecting Calibration Mode	12
3-3-3. Minimum Scale Division Setting.....	12
3-3-4. Torque Setting	13
3-3-5. Actual Torque Setting	14
3-3-6. Zero Calibration.....	15
3-3-7. Span Calibration.....	16
3-3-8. Calibration End.....	17
3-4. Zero/Span Fine Adjustment Function	18
3-4-1. Selecting Zero Point Fine-adjustment Mode.....	18
3-4-2. Selecting Span Point Fine-adjustment Mode.....	19
4. FUNCTION MODE	20
4-1. Selecting Function Mode.....	20
4-2. Function List.....	21

1. Part Names and Functions

1-1. Front Panel

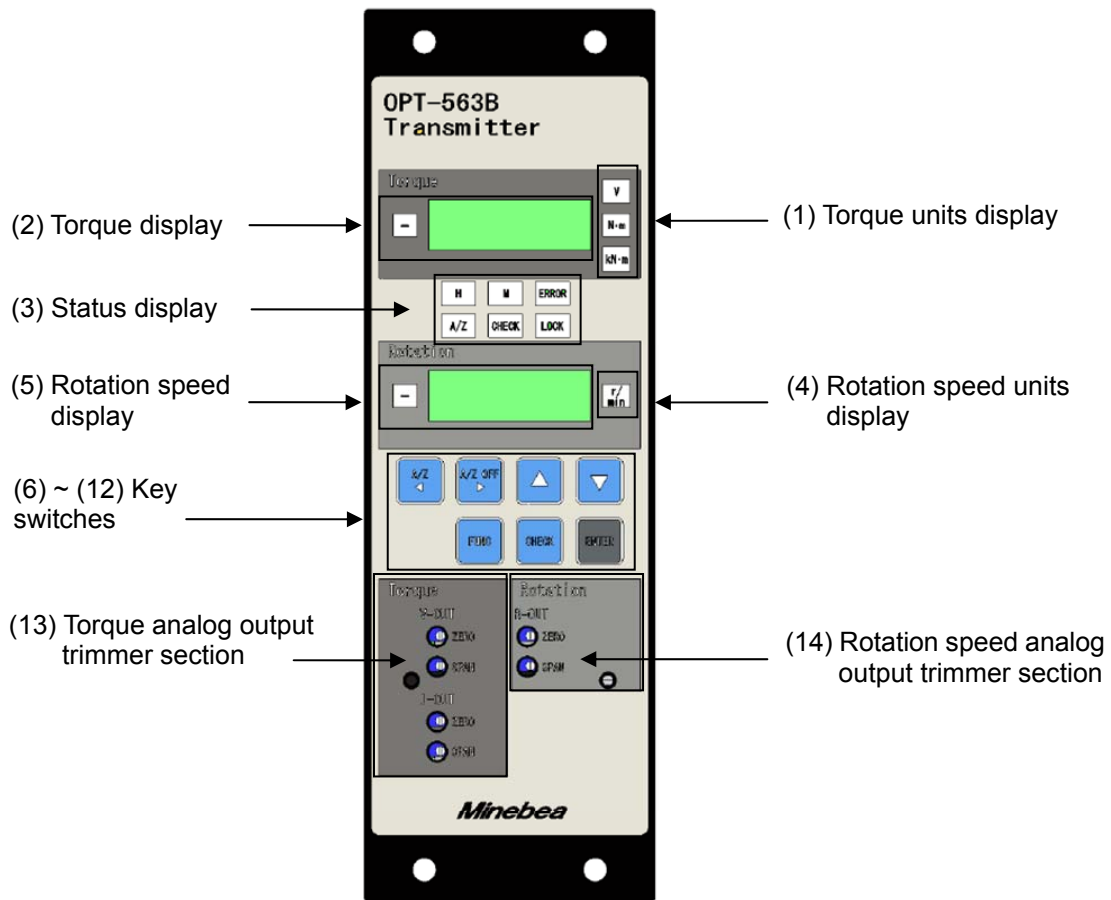

(1) Torque units display

Displays the measurement units set.

(2) Torque display

Displays the torque reading and [OL] (for over limit).

(3) Status display

Indicates the OPT-563B status.

H : Illuminates when the torque meter light level is normal.

M : Illuminates when the torque meter light level is low.

Note that [M] does not illuminate if used in conjunction with the DBX-001 power supply box.

A/Z : Illuminates when the A/Z function operates.

CHECK : Illuminates when the  key is pressed to turn CHECK on.

LOCK : Illuminates when external control input LOCK to COM1 is short-circuited.

ERROR : Illuminates when an error signal is output.

(4) Rotation speed units display

Displays the rotation speed units.

(5) Rotation speed display

Displays the rotation speed and [OS] (for overspeed).

(6)  key

Turns on the A/Z function. Also moves the setting digit to the left when setting numerical values.

(7)  key

Turns off the A/Z function. Also moves the setting digit to the right when setting numerical values.

(8)  key

Increments the digit selected when setting numerical values.

(9)  key

Decrements the digit selected when setting numerical values.

(10)  key

Used to select function mode. Also used to return to measurement mode without entering the value when setting. Depress for at least 2 seconds to select function mode.

(11)  key

Used to turn the CHECK value on or off. Depress for at least 2 seconds to turn on the CHECK value.

(12)  key

Used for registering settings.

(13) Torque analog output trimmer section

Torque analog output (VOUT and IOUT) zero point and span point trimmer adjustment (fine adjustment) section

(14) Rotation speed analog output trimmer section

Rotation speed analog output (ROUT) zero point and span point adjustment (fine adjustment) section

1-2. Rear Panel

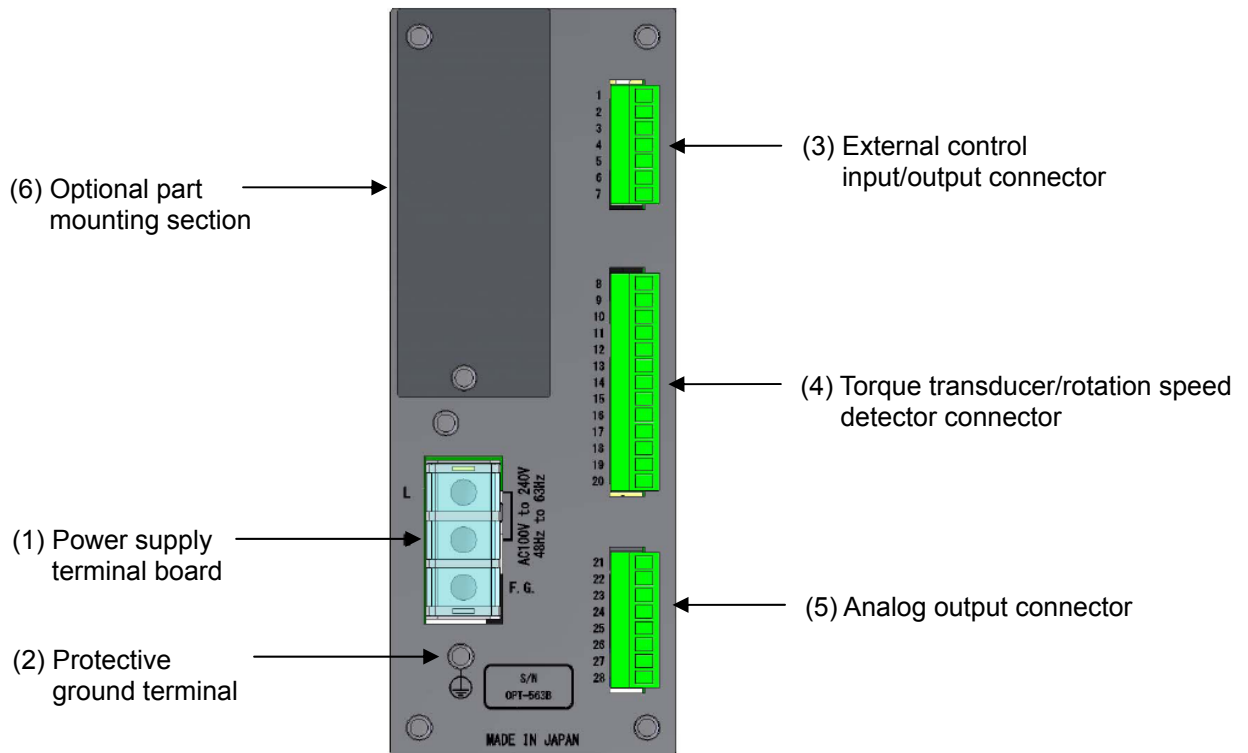

(1) Power supply terminal board

Connected to the AC power supply and grounding wire.

(2) Protective ground terminal

Connect this to ground to eliminate noise effects such as static electricity. Do not connect any wires other than the grounding wire.

This connector is internally linked to F.G. on the power supply terminal board.

(3) External control input/output connector

Used to connect the external control device.

(4) Torque transducer/rotation speed detector connector

Connect the signal cable to the torque transducer/rotation speed detector (MP-9820).

(5) Analog output connector

Connect the signal cable to the analog input device.

(6) Optional part mounting section

One optional part (RS-232C, RS-422/485, PROFIBUS, or CANopen) can be mounted.

2. Operating Instructions

This section describes how to operate the equipment using the keys on the front panel.



CAUTION

Stop measuring before operating the keys. There is a risk of malfunctioning if the keys are operated while measurement is in progress.



Key operations in measurement mode are enabled by depressing for approximately 1 second.

2-1. Key

2-1-1. When Operated in Measurement Mode

This selects function mode and  is displayed on the setting display. Function setting or other modes can be selected in this mode.

2-2. Key

2-2-1. When Operated in Measurement Mode

Pressing this button activates the auto-zero function and zeros the torque reading if the value displayed on the torque display is 10% or less of the maximum value. [A/Z] is also displayed on the status display.

2-2-2. When Operated in Other Modes

Pressing the  key when a setting is displayed causes the flashing digit to move to the left in the sequence 10^1 , 10^2 , 10^3 , 10^4 . (Note that the range of movement will vary depending on the number of digits and sign displayed.)

2-3. Key

2-3-1. When Operated in Measurement Mode

This cancels the auto-zero function, and [A/Z] disappears on the status display.

2-3-2. When Operated in Other Modes

Pressing the  key when a setting is displayed causes the flashing digit to move to the right in the sequence 10^4 , 10^3 , 10^2 , 10^1 . (Note that the range of movement will vary depending on the number of digits and sign displayed.)

2-4. Key

2-4-1. When Operated in Measurement Mode

This has no effect.

2-4-2. When Operated in Other Modes

Setting increment

Pressing the  key when a setting is displayed increments the value in sequence from 0 to 9, and then back to 0.

Fine adjustment increment

Pressing the  key for fine adjustment of the zero point, span point, asymmetry correction, linearization correction, or analog output increments the corresponding value.

2-5. Key

2-5-1. When Operated in Measurement Mode

This has no effect.

2-5-2. When Operated in Other Modes

Setting decrement

Pressing the  key when a setting is displayed decrements the value in sequence from 0 to 1, and then back to 0.

Fine adjustment decrement

Pressing the  key for fine adjustment of the zero point, span point, asymmetry correction, linearization correction, or analog output decrements the corresponding value.

2-6. Key

2-6-1. When Operated in Measurement Mode

[CHECK] illuminates on the status display, and the value (CHECK value) set in function mode F-20 is output from the torque analog output (V-OUT/I-OUT). For further details, refer to Section 9-2.

2-6-2. When Operated in Other Modes

This has no effect.

2-7. Key

Pressing the  key registers the setting altered within the system.

3. Calibration

Calibration refers to the process of adjusting the display reading to match the torque acting on the torque transducer in order to ensure that the electrical signal from the torque transducer is displayed as an accurate torque figure.

For example, this adjustment ensures that an accurate reading of 1000.0 N·m is given when a torque of 1,000 N·m acts on the torque transducer.

The equipment must always be calibrated before using for the first time or after replacing a torque transducer.

When calibrating the equipment before using for the first time, calibrate by entering the numerical values, referring to the calibration certificate sheet provided when the torque transducer was purchased.

When calibrating the equipment after replacing a torque transducer, calibrate by entering the numerical values, referring to the calibration certificate sheet provided with the torque transducer purchased.

3-1. Settings Required for Calibration

- (1) Minimum scale division
The minimum measurement interval. The available settings are [1], [2], [5], and [10].
The value set for [SPAN value/MIN. SCALE DIVISION] will form the display resolution.
- (2) SPAN value
The maximum torque value that can be measured by the torque transducer.
- (3) ZERO calibration
The setting to be calibrated to ensure that the equipment torque reading is zero when no torque is applied to the torque transducer (initial torque state). This can be calibrated either using the torque value (initial torque state) or by entering the torque transducer output value.
- (4) SPAN calibration
The setting to be calibrated to ensure that the variations in the electrical signal from the torque transducer are displayed on the equipment correctly as the torque when a torque is applied to the torque transducer. This can be calibrated either using the torque value (span torque state) or by entering the torque transducer output value.
- (5) Calibration data selection
The equipment can save up to four sets of calibration data. Select the location for saving the calibration data by selecting Calibration Data 1 to 4 before calibrating using F-59. If the equipment is jointly calibrated at our site, the calibration data will be stored to [Calibration Data 1].

3-2. Settings to be Altered As Necessary After Calibration

For details of the setting instructions, refer to Instruction Manual EN294-1596*.

- (1) Symmetry correction
This function corrects torsional span errors in the clockwise and counter-clockwise directions.
- (2) Linearization correction
This function minimizes measuring errors by correcting up to five points, excluding zero and span.
- (3) Change polarity
This function inverts the polarity of the torque transducer output.
- (4) Decimal place
Sets the decimal place for the torque reading on the equipment.
- (5) Units
Adds units to the torque reading on the equipment.



- Recalibrate as necessary if the usage environment changes.
- The maximum readout resolution for valid performance is 10,000.
- In span calibration, use a value of at least 2/3 of the span to minimize calibration errors.

3-3. Calibration Procedure

3-3-1. Calibration in Measurement Mode

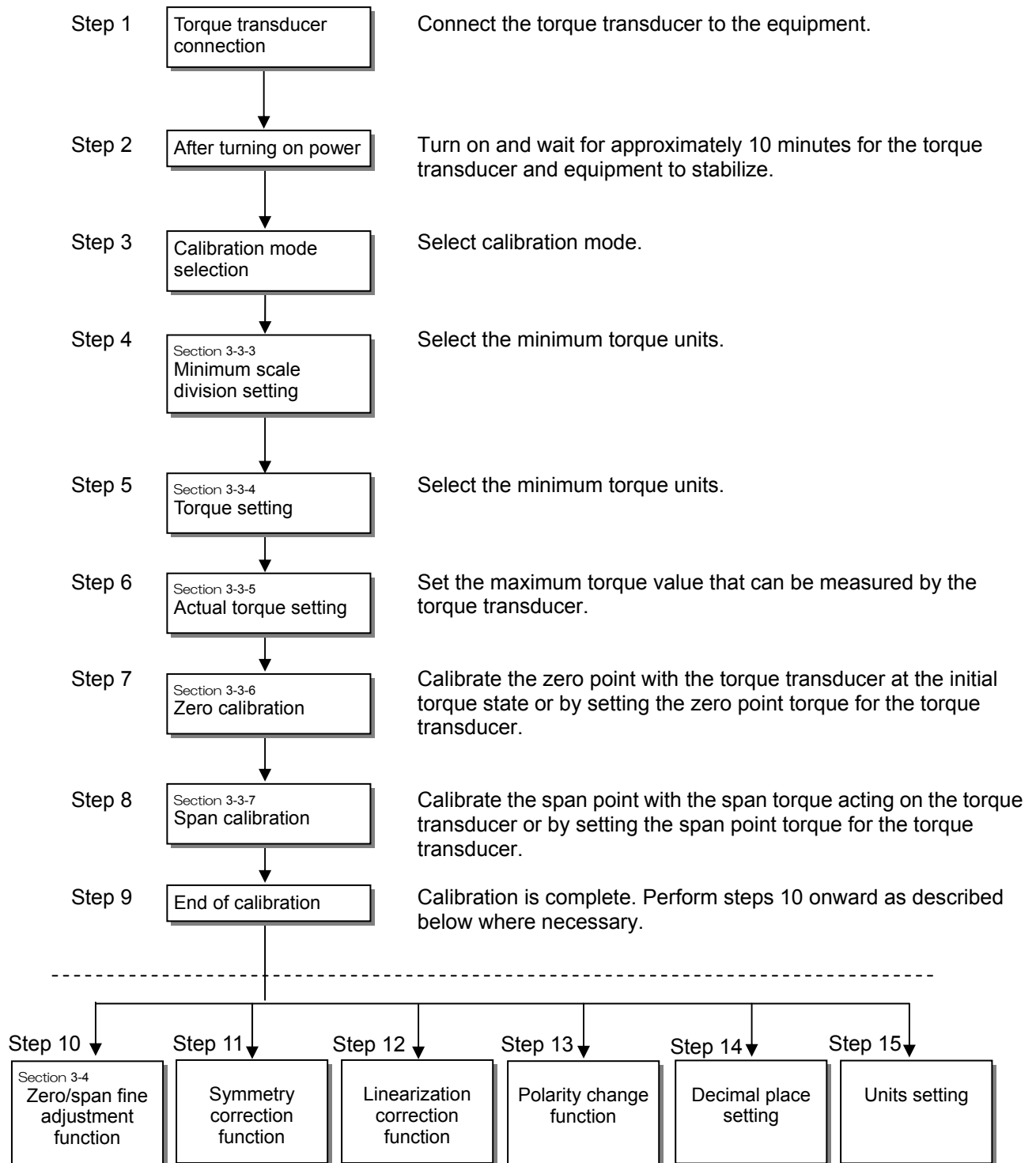

- Steps 4 to 9 must be carried out in sequence. The calibration results will not be updated if the procedure is not completed up to step 9.
- The A/Z function is canceled once calibration is completed (up to step 9).
- The A/Z function is canceled if step 10, 11, or 12 is performed.
- For details of steps 11 to 15, refer to Instruction Manual EN294-1596*.

3-3-2. Selecting Calibration Mode

Calibration mode can be selected from measurement mode as follows.

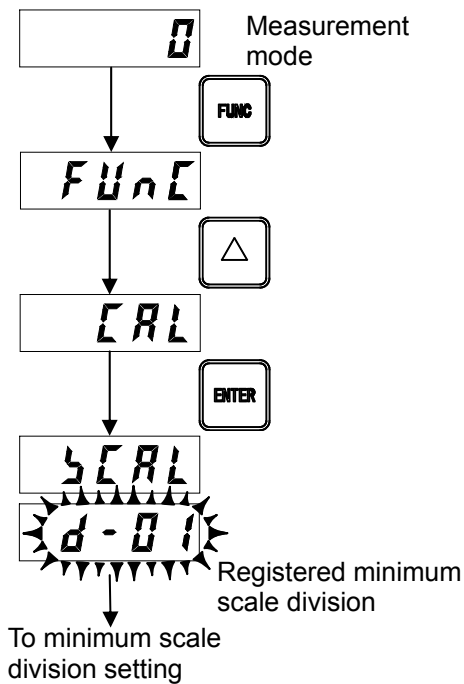

FuNC appears in the upper part when the key is depressed for approximately 2 seconds in measurement mode.

The upper display reads **CAL** when the key is pressed.

The upper display reads **SCAL** and **d-01** flashes on the lower display, indicating calibration mode has been selected when the key is pressed. (If the equipment has been previously calibrated, the minimum scale division registered at that time will be displayed.)

3-3-3. Minimum Scale Division Setting

Set the minimum scale division for torque.

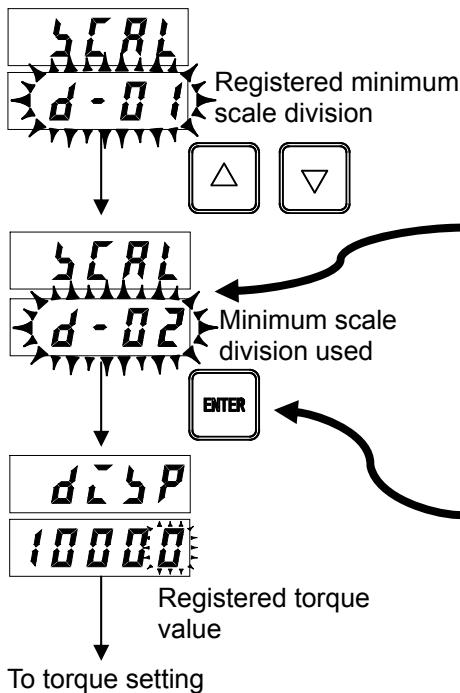

Use the or key to set the required minimum scale division on the lower display. Select from [1], [2], [5], or [10].

* Enter value (1) on the calibration certificate sheet. (No decimal point)
For example, if the minimum digit is 100.00 N·m, set to [d-01].

: Selects the minimum scale division.

: Cancels the setting and returns to measurement mode.

: Registers the value displayed and proceeds to the next step.

Press the key after setting. (If the equipment has been previously calibrated, the torque value registered at that time will be displayed.)



The maximum readout resolution for valid performance is 10,000.



3-3-4. Torque Setting

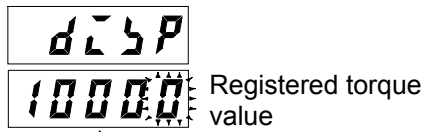

Set the maximum torque displayed.





Use the     keys to change the torque on the lower display to the required value.

* Enter value (2) on the calibration certificate sheet. (No decimal point)
For example, if the maximum indication is 100.00 N·m, set to [10000].

  : Alters the value of the digit to be altered.

  : Selects the digit to be altered.

 : Cancels the setting and returns to measurement mode.

 : Registers the value displayed and proceeds to the next step.

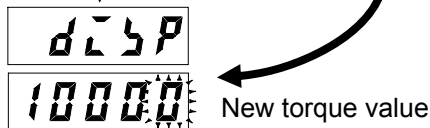

Press the  key after setting.

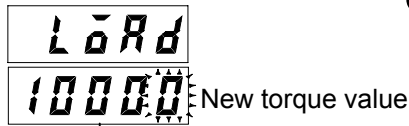

To actual torque setting

3-3-5. Actual Torque Setting

Set actual torque acting on the torque transducer (or torque transducer output).

When calibrating by entering numerical values, set the same value as set in "3-3-4 Torque Setting".

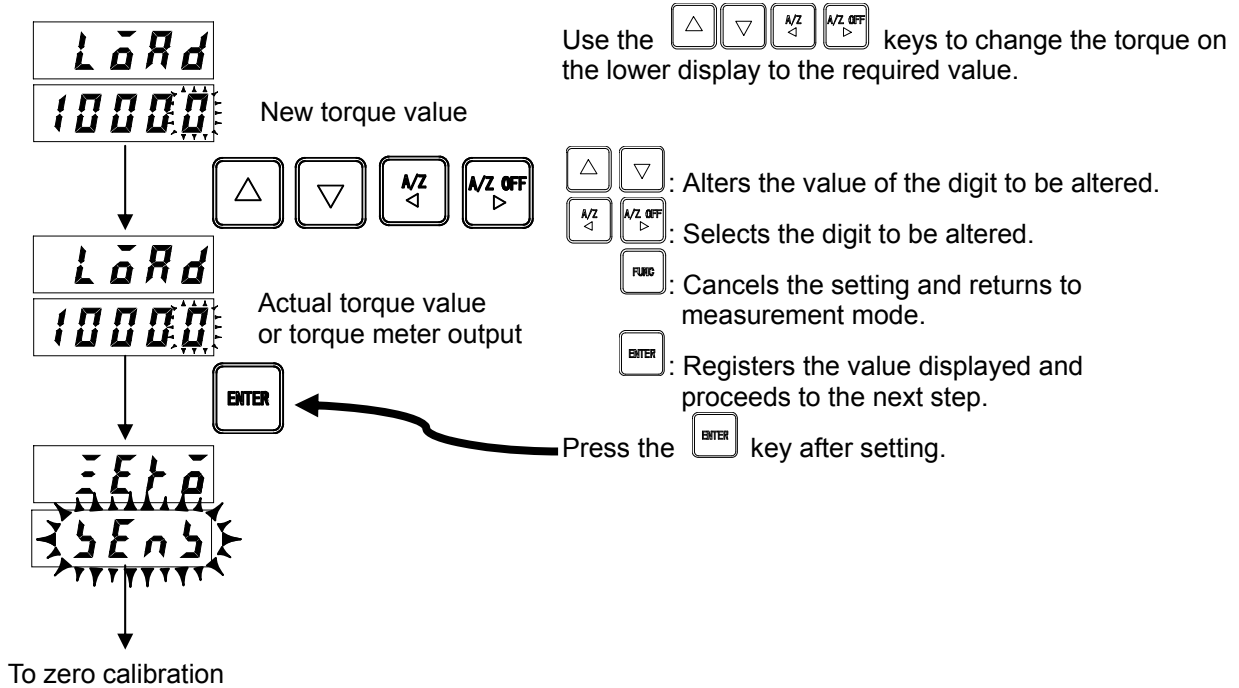

* Enter value (3) on the calibration certificate sheet. (No decimal point)

For example, if the maximum indication is 100.00 N·m, set to [10000].



3-3-6. Zero Calibration



Register the input at the zero point.

To calibrate by entering the torque value for the torque transducer, press the  key and then press the  key.

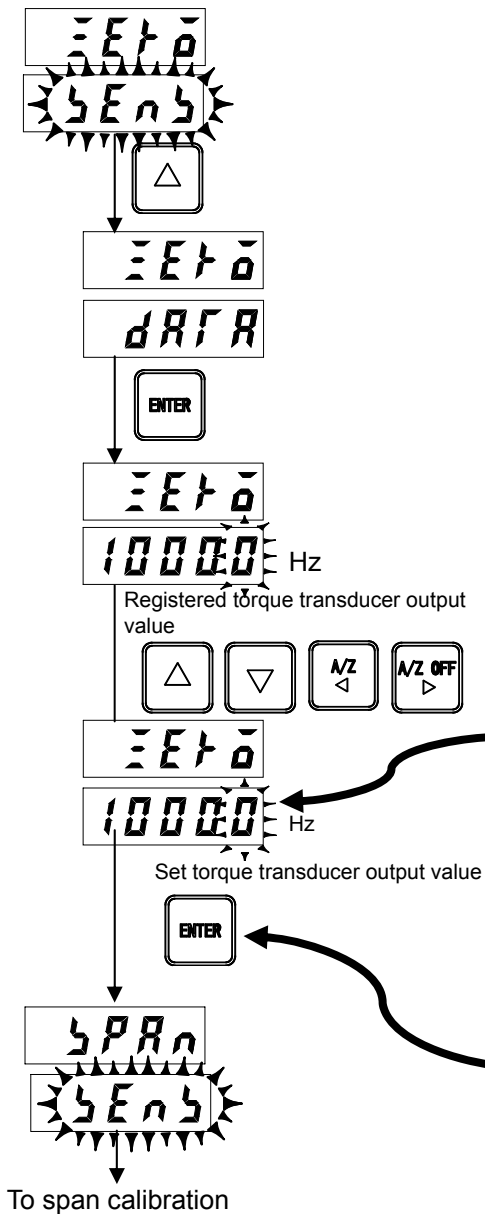
Calibrate zero by entering the zero point torque (frequency) for the torque transducer.



Calibration by entering the torque value for the torque transducer

Press the  key to display  in the lower display, and then press the  key to display the value.



The value displayed will be the output frequency for the torque transducer at the initial torque state previously registered.



Set the torque value (frequency) corresponding to the zero point in 1 Hz intervals.

* Enter the torque calibration value zero frequency included on the calibration certificate sheet for the torque transducer.

* Enter value (4) on the calibration certificate sheet. (No decimal point)

For example, if the torque calibration value (zero) is 9.957 kHz, set to [9957].

  : Alters the value of the digit to be altered.

  : Selects the digit to be altered.

 : Cancels the setting and returns to measurement mode.

 : Registers the value displayed and proceeds to the next step.

Press the  key after setting.

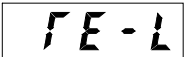

Zero calibration error display

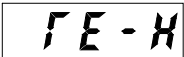
 : The display flashes for approximately 2 seconds when the torque transducer frequency output is less than 9,500 Hz or if the value entered is less than 9,500 Hz.

 : The display flashes for approximately 2 seconds when the torque transducer frequency output exceeds 10,500 Hz or if the value entered exceeds 10,500 Hz.

3-3-7. Span Calibration



Register the input at the span point.

To calibrate by entering the torque value for the torque transducer, press the  key and then press the  key.

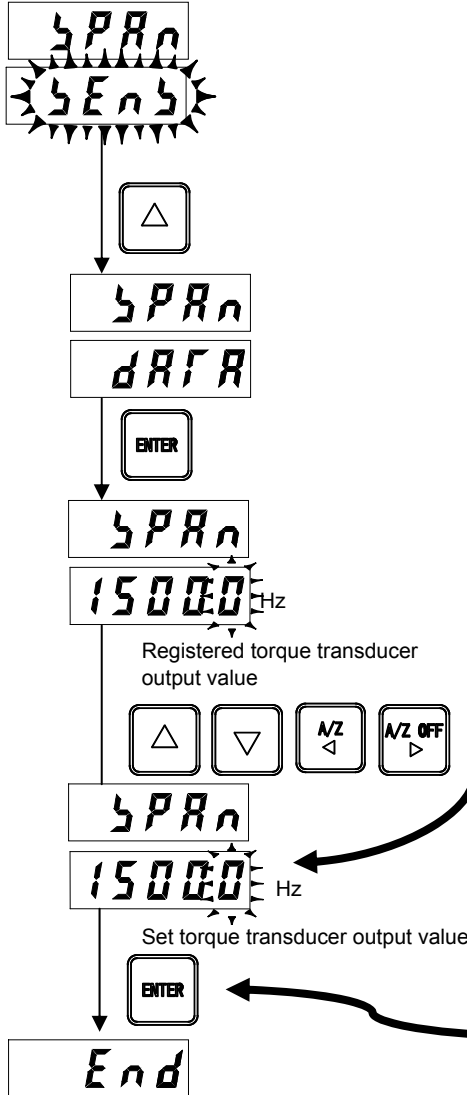
Calibrate span by entering the span point torque (frequency) for the torque transducer.





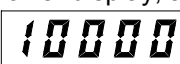



Calibration by entering the torque value for the torque transducer

Press the  key to display  in the lower display, and then press the  key to display . The value displayed will be the output frequency for the torque transducer at the span point previously registered. Set the torque value (frequency) corresponding to the span point in 1 Hz intervals.

* Enter the torque calibration value span frequency included on the calibration certificate sheet for the torque transducer.

* Enter value (5) on the calibration certificate sheet. (No decimal point)

For example, if the torque calibration value (span) is 14.913 kHz, set to [14913].

-   : Alters the value of the digit to be altered.
-   : Selects the digit to be altered.
-  : Cancels the setting and returns to measurement mode.
-  : Registers the value displayed and proceeds to the next step.

Press the  key after setting.

Span calibration error display

 : The display flashes for approximately 2 seconds when [span point torque transducer output frequency or span point torque transducer value entered] - [zero point torque transducer output frequency or zero point torque transducer value entered] ≤ 0 or when the torque transducer output frequency is less than 14,500 Hz or if the value entered is less than 14,500 Hz.

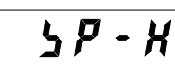
 : The display flashes for approximately 2 seconds when the torque transducer output frequency exceeds 15,500 Hz or if the value entered exceeds 15,500 Hz.



In span calibration, use a torque value of at least 2/3 of the display torque to minimize calibration errors.

3-3-8. Calibration End

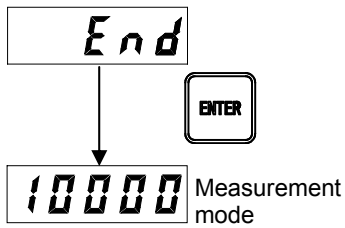

Displays  after span calibration ends.

Press the  key to exit calibration mode.

The system switches to measurement mode and the data set is registered.



- The calibration values (zero point and span) will not be entered unless the procedure is performed in sequence up to this step.
- Calibration can be performed only in the counter-clockwise torsional direction.
- The A/Z function is canceled once calibration is completed.

3-4. Zero/Span Fine Adjustment Function

This function fine-adjusts the zero point and span point if there are discrepancies between the actual torque and the reading displayed.

3-4-1. Selecting Zero Point Fine-adjustment Mode

Zero point fine-adjustment mode can be selected from measurement mode as follows.

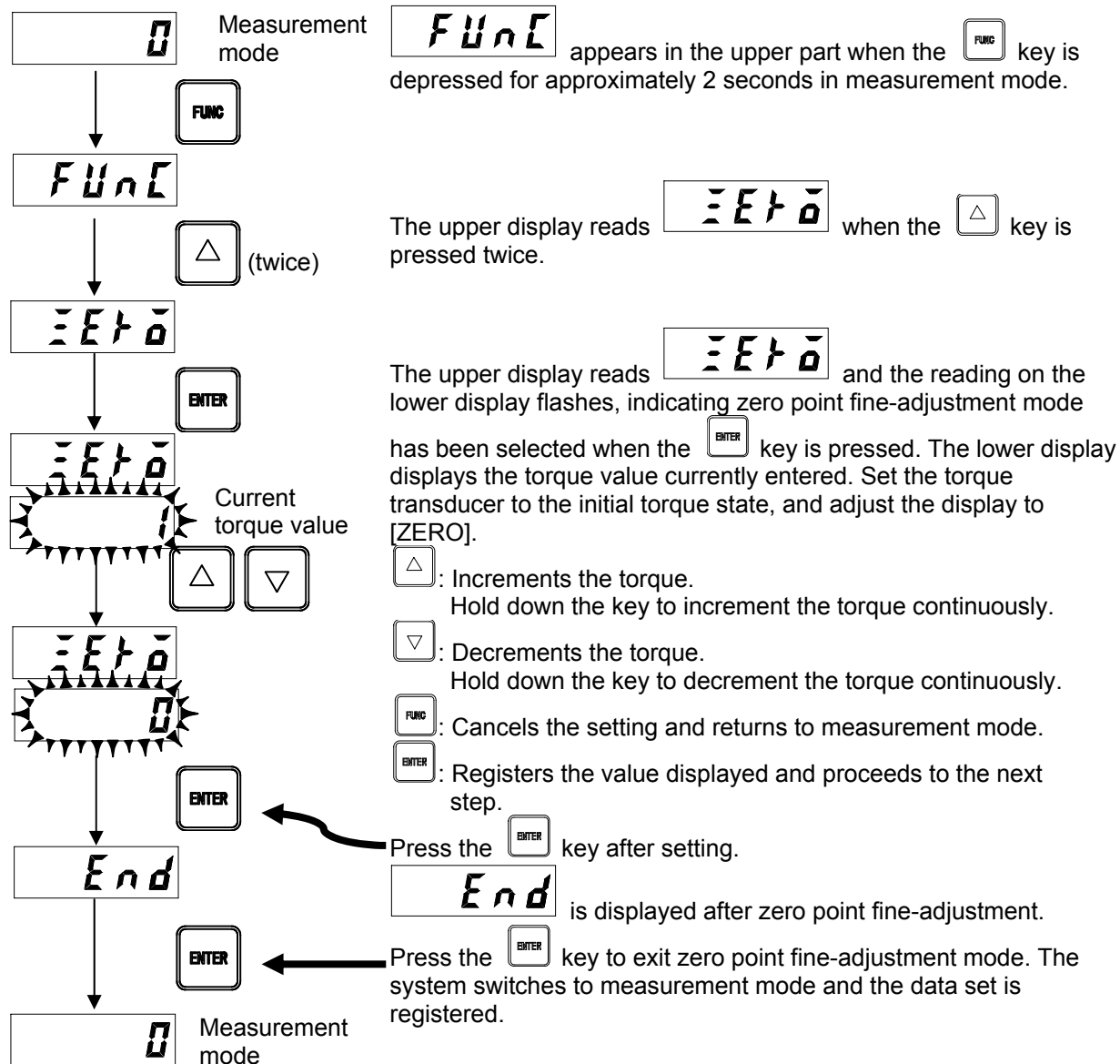

3-4-2. Selecting Span Point Fine-adjustment Mode

Span point fine-adjustment mode can be selected from measurement mode as follows.

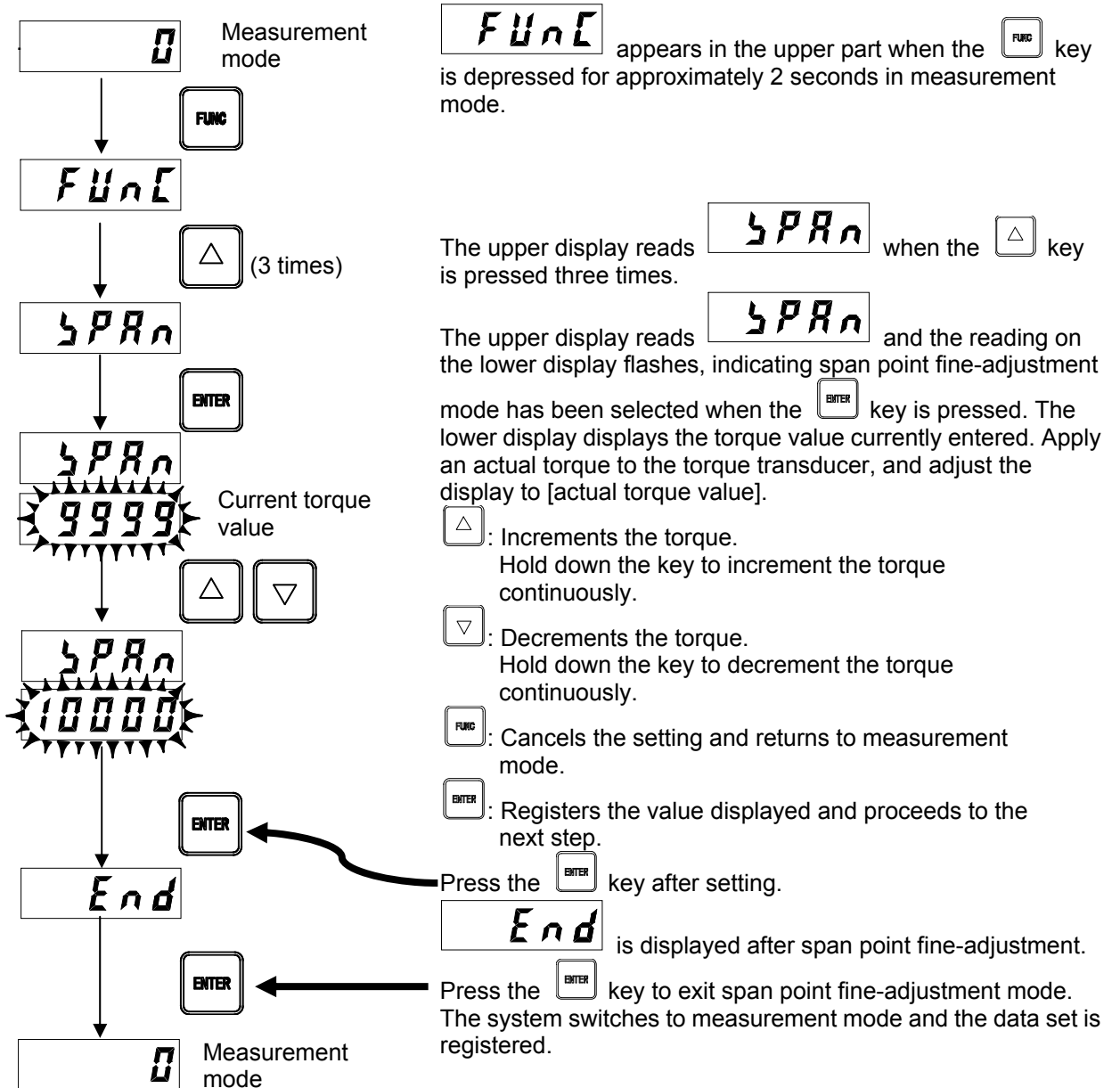

- The change polarity setting will be temporarily canceled for zero/span fine-adjustment. (Restored after adjustment)
- The A/Z function is canceled once the zero/span fine-adjustment function ends.

4. Function Mode

4-1. Selecting Function Mode

Function mode can be selected from measurement mode as follows.

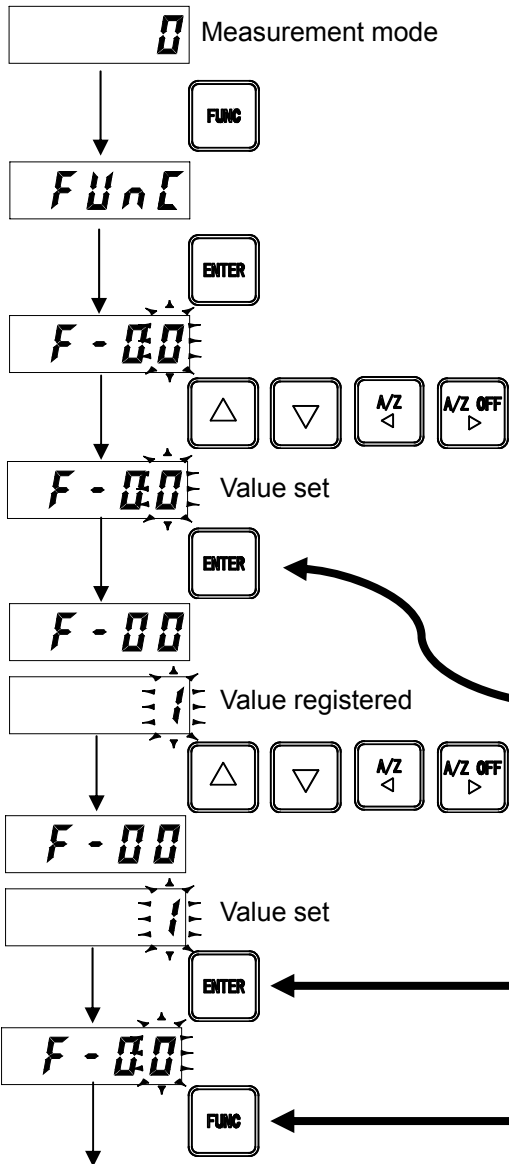

FUNC appears in the upper part when the **FUNC** key is depressed for approximately 2 seconds in measurement mode.

The upper display reads **F-00** when the **ENTER** key is pressed.

Use the **▲ ▼ ▲/Z ▲/Z OFF** keys to select the required function number on the upper display.

▲ ▼: Alters the value of the digit to be altered.

▲/Z ▲/Z OFF: Selects the digit to be altered.

FUNC: Cancels the setting and returns to measurement mode.

ENTER: Registers the value displayed and proceeds to the next step.

Press the **ENTER** key after setting. The lower display changes to display the function details.

Use the **▲ ▼ ▲/Z ▲/Z OFF** keys to select the required function number on the lower display.





The upper display reads **F-00** when the **ENTER** key is pressed, indicating that function registration is complete.

Press the **FUNC** key to exit function mode and return to measurement mode.

To measurement mode

4-2. Function List

Function No.	Item	Setting value	Details
F-01	Decimal place	●0	No decimal point
		1	1000.0
		2	100.00
		3	10.000
		4	1.0000
F-02	Torque display units	●0	N·m
		1	kN·m
		2	V
F-04	Display cycles	0	4 cycles/s
		●1	20 cycles/s
F-05	Torque analog filter	0	1 Hz
		1	10 Hz
		2	30 Hz
		3	50 Hz
		4	100 Hz
		5	300 Hz
		6	500 Hz
		●7	1 kHz
F-06	Torque digital filter	00~88	No. of moving-average samples = $2^m + 2^n$ m: 10^1 setting, n: 10^0 setting
		●00	
F-07	Rotation speed analog filter	0	1 Hz
		●1	10 Hz
F-08	Rotation speed digital filter	00~88	No. of moving-average samples = $2^m + 2^n$ m: 10^1 setting, n: 10^0 setting
		●00	
F-09	Torque stabilization filter No. of averaging	0	No. of moving-average samples: 1
		1	No. of moving-average samples: 2
		2	No. of moving-average samples: 4
		3	No. of moving-average samples: 8
		4	No. of moving-average samples: 10
		5	No. of moving-average samples: 12
		●6	No. of moving-average samples: 14
		7	No. of moving-average samples: 16
		8	No. of moving-average samples: 32
F-10	Torque stabilization filter Time width setting	000~999	Unit: 10 ms 000: Torque stabilization filter off
		●000	
F-11	Torque stabilization filter Data width setting	00~99	Unit: DIGIT 00: Torque stabilization filter off
		●20	

Function No.	Item	Setting value	Details
F-15	Rotation speed stabilization filter No. of averaging	0	No. of moving-average samples: 1
		1	No. of moving-average samples: 2
		2	No. of moving-average samples: 4
		3	No. of moving-average samples: 8
		4	No. of moving-average samples: 10
		5	No. of moving-average samples: 12
		●6	No. of moving-average samples: 14
		7	No. of moving-average samples: 16
		8	No. of moving-average samples: 32
F-16	Rotation speed stabilization filter Time width setting	000~999	Unit: 10 ms
		●000	000: Rotation speed stabilization filter off
F-17	Rotation speed stabilization filter Data width setting	00~99	Unit: DIGIT
		●20	00: Rotation speed stabilization filter off
F-18	Key lock	0000 ~1111 ●0000	0: Off 1: On 10 ⁰ digit:  10 ¹ digit:  10 ² digit:  10 ³ digit: 
F-19	Polarity change	●0	Torque in counter-clockwise direction is positive.
		1	Torque in clockwise direction is positive.
F-20	CHECK value	0~20	Refer to Section 9-2-3.
		●16	
F-21	Torque analog output Max. display value	1~99 999	Unit: DIGIT
		●10 000	
F-22	Rotation speed analog output Max. display value	1~27 500	Unit: DIGIT
		●25 000	
F-23	Rotation direction polarity	●0	+
		1	-
F-24	Rotation detection input signal format	●0	Off
		1	Measured using 2 rotation detectors
		2	Measured using 1 rotation detector. Rotation direction detected using external input signal
		3	Measured using 1 rotation detector. Rotation direction cannot be detected.

Function No.	Item	Setting value	Details
F-25	No. of rotation detection gears	●0	120
		1	240
		2	360
F-26	Selecting A/Z data save destination	●0	RAM
		1	EEPROM
F-30	RS-232C operating mode	●0	Command mode
		1	Stream mode
F-31	RS-232C stream output target	●0	Torque display data
		1	Input torque A/D data
		2	Rotation speed display data
		3	Frequency data
F-32	RS-232C/RS-422/RS-485 Baud rate	0	1,200 bps
		1	2,400 bps
		2	4,800 bps
		●3	9,600 bps
		4	19,200 bps
		5	38,400 bps
		6	57,600 bps
		7	115,200 bps
F-33	RS-232C/RS-422/RS-485 Data bit length	●0	7 bit
		1	8 bit
F-34	RS-232C/RS-422/RS-485 Parity bit	0	None
		●1	Odd
		2	Even
F-35	RS-232C/RS-422/RS-485 Stop bit	●0	1 bit
		1	2 bit
F-36	RS-232C/RS-422/RS-485 Terminator	0	CR
		●1	CR+LF
F-37	RS-232C/RS-422/RS-485 Decimal point	●0	No
		1	Yes
F-38	RS-422/485 address	00~31	
		●00	
F-39	RS-422/485 selection	●0	RS-422
		1	RS-485
F-40	RS-485 data delay time	000~999	Unit: 10 ms Can be set in range 0~9.99 s.
		●001	

Function No.	Item	Setting value	Details
F-41	PROFIBUS Station No.	000~125	
		●000	
F-42	CANopen Node ID	001~127	
		●001	
F-43	CANopen Baud rate	0	10 kbps
		1	20 kbps
		2	50 kbps
		3	100 kbps
		4	125 kbps
		5	250 kbps
		6	500 kbps
		●8	1 Mbps
F-45	CANopen PDO output frequency	0~100	0: Off
		●100	Unit: 1 ms
F-50	Maintenance 1	00000	0~99 999 (Do not use)
F-51	Maintenance 2	00000	0~99 999 (Do not use)
F-55	Calibration prohibited	0000	0: Calibration permitted 1: Calibration prohibited 10 ⁰ digit: Calibration data 1 10 ¹ digit: Calibration data 2 10 ² digit: Calibration data 3 10 ³ digit: Calibration data 4
F-56	Symmetry correction clear	0	Clear data corrected using symmetry correction function.
F-57	Clearing counter-clockwise linearization correction	0	Clear data corrected using linearization correction function. (Counter-clockwise direction)
F-58	Clearing clockwise linearization correction	0	Clear data corrected using linearization correction function. (Clockwise direction)
F-59	Calibration data selection	●0	Calibration data 1
		1	Calibration data 2
		2	Calibration data 3
		3	Calibration data 4
F-60	Calibration 1 Increment	1	Datum value (initial value)
F-61	Calibration 1 Maximum display value	10000	Datum value (initial value)
F-62	Calibration 1 Actual torque value	10000	Datum value (initial value)
F-63	Calibration 1 ZERO A/D	0x1FFFF	Datum value (initial value)
F-64	Calibration 1 +SPAN A/D	0x3AAAA	Datum value (initial value)
F-65	Calibration 1 -SPAN A/D	0x5555	Datum value (initial value)
F-66	Calibration 1 ZERO frequency conversion value	10000	Datum value (initial value)
F-67	Calibration 1 +SPAN frequency conversion value	15000	Datum value (initial value)
F-68	Calibration 1 -SPAN frequency conversion value	5000	Datum value (initial value)

Function No.	Item	Setting value	Details
F-70	Calibration 2 Increment	1	Datum value (initial value)
F-71	Calibration 2 Maximum display value	10000	Datum value (initial value)
F-72	Calibration 2 Actual torque value	10000	Datum value (initial value)
F-73	Calibration 2 ZERO A/D	0x1FFFF	Datum value (initial value)
F-74	Calibration 2 +SPAN A/D	0x3AAAA	Datum value (initial value)
F-75	Calibration 2 -SPAN A/D	0x5555	Datum value (initial value)
F-76	Calibration 2 ZERO frequency conversion value	10000	Datum value (initial value)
F-77	Calibration 2 +SPAN frequency conversion value	15000	Datum value (initial value)
F-78	Calibration 2 -SPAN frequency conversion value	5000	Datum value (initial value)
F-80	Calibration 3 Increment	1	Datum value (initial value)
F-81	Calibration 3 Maximum display value	10000	Datum value (initial value)
F-82	Calibration 3 Actual torque value	10000	Datum value (initial value)
F-83	Calibration 3 ZERO A/D	0x1FFFF	Datum value (initial value)
F-84	Calibration 3 +SPAN A/D	0x3AAAA	Datum value (initial value)
F-85	Calibration 3 -SPAN A/D	0x5555	Datum value (initial value)
F-86	Calibration 3 ZERO frequency conversion value	10000	Datum value (initial value)
F-87	Calibration 3 +SPAN frequency conversion value	15000	Datum value (initial value)
F-88	Calibration 3 -SPAN frequency conversion value	5000	Datum value (initial value)
F-90	Calibration 4 Increment	1	Datum value (initial value)
F-91	Calibration 4 Maximum display value	10000	Datum value (initial value)
F-92	Calibration 4 Actual torque value	10000	Datum value (initial value)
F-93	Calibration 4 ZERO A/D	0x1FFFF	Datum value (initial value)
F-94	Calibration 4 +SPAN A/D	0x3AAAA	Datum value (initial value)
F-95	Calibration 4 -SPAN A/D	0x5555	Datum value (initial value)
F-96	Calibration 4 ZERO frequency conversion value	10000	Datum value (initial value)
F-97	Calibration 4 +SPAN frequency conversion value	15000	Datum value (initial value)
F-98	Calibration 4 -SPAN frequency conversion value	5000	Datum value (initial value)
F-99	Memory clear	-	Returns function settings to default settings.

試験成績表

Calibration Certificate

トルク変換器(Torque Transducer)	型式(Type)	TMHS-100NM	製造番号(S/N)	K330253
トランスミッタ(Transmitter)	型式(Type)	OPT-563B	製造番号(S/N)	1320432
ケーブル長さ(Cable length)	10 m	最高回転数: Max.Speed	25000 rpm	
試験年月日(Date)	2013/3/6	温度(Temp.)°C	25	湿度(Humi.)% 50

検量試験(Torque Performance Test)

基準値(Specification)			+側(+Side)				-側(-Side)			
トルク (Torque)	表示 (Display)	出力電圧 (Output)	加重 (Increase)	減重 (Decrease)	加重 (Increase)	減重 (Decrease)	加重 (Increase)	減重 (Decrease)	加重 (Increase)	減重 (Decrease)
N·m	N·m	V	N·m		V		N·m		V	
0	0.00	0.000	0.00	0.01	0.000	0.001	0.01	0.00	0.001	0.000
20	20.00	2.000	0.00	0.00	0.000	0.000	0.00	0.00	0.000	0.000
40	40.00	4.000	0.00	0.00	0.000	0.000	0.00	0.00	0.000	0.000
60	60.00	6.000	0.00	0.00	0.000	0.000	0.00	0.00	0.000	0.000
80	80.00	8.000	0.00	0.00	0.000	0.000	0.00	0.00	0.000	0.000
100	100.00	0.000	0.00	0.00	0.000	0.000	0.00	0.00	0.000	0.000
検量精度 (Accuracy)	0.02%R.O.	0.05%R.O.	100.00 %R.O.		100.00 %R.O.		100.00 %R.O.		100.00 %R.O.	

トルク校正値 (Calibration value)	ZERO	9.957 kHz	(4)
	SPAN	14.913 kHz	(5)
CHECK値(CHECK value)	8.000	V	

最小読取(Minimum digit)	0.01 N·m	(1)
最大表示(Max indication)	100.00 N·m	(2)(3)

工場出荷時のFunction No.設定値(Registered value of each Function No. at the factory)

Function No.	01						
設定値(Setting value)	2						

* 上記はデフォルト値から変更した値です。上記以外のFunction No.の設定値は、取扱説明書をご参照下さい。
(See Instruction manual for the other set value except above Function No.)

回転試験(Revolution Performance Test)

試験内容(Test Contents)	単位 (Unit)	基準値 (Specification)	試験結果 (Result)
回転による零点変動(ノイズ) (Revolution effect on Zero Balance/noise)	%R.O.p-p	0.5	0.41

検査者(Inspector)

検査責任者(Supervisor)

●The contents of this manual may subject to change without notice.

HEAD QUARTER: **MinebeaMitsumi Inc.**

4106-73 Miyota, Miyota-machi, Kitasaku gun, Nagano-ken 389-0293 Japan
Tel: +81-267-32-2200 Fax: +81-267-31-1350

Sensing Device Product Sales Management:

1-1-1, Katase, Fujisawa-shi, Kanagawa-ken, 251-8531 Japan
Tel: +81-466-23-2681 Fax: +81-466-22-7191

Sensing Device Business Unit

FUJISAWA PLANT 1-1-1, Katase, Fujisawa-shi, Kanagawa-ken, 251-8531 Japan
Tel: +81-466-22-7151 Fax: +81-466-22-1701

KARUIZAWA PLANT 4106-73 Miyota, Miyota-machi, Kitasaku gun, Nagano-ken 389-0293 Japan
Tel: +81-267-31-1309 Fax: +81-267-31-1353

HOME PAGE ADDRESS <http://www.minebea-mcd.com>