

Minebea

TORQUE TRANSDUCER

TMNR-~~※~~NM

(for Torque Transducer)

Instruction Manual

MinebeaMitsumi Inc.

Sensing Device Business Unit

Read this instruction manual thoroughly prior to start use of this product.
 Be sure to observe the notes and cautions mentioned in this text of instruction manual.
 You will please file this manual in such a way that it is available anytime immediately whenever
 you want to refer to.

The following are the marks and symbols used in this instruction manual. The following are the marks and symbols for the matters which you must not do absolutely or to which you must pay full attention or you must refer to. Be sure to peruse the paragraphs marked with these marks and symbols.

	<p>CAUTION If not observed , it will cause troubles of injury or damage done to properties or result in endangering a human life. DO NOT DO THE MATTERS MAKED WITH THIS MARK ABSOLUTELY.</p>
-----------------------------------------------------------------------------------	-----------------------------------------------------------------------------------------------------------------------------------------------------------------------------------------------------------------

	<p>This mark shows the limitation or attention which you must pay when operating or working . Be sure to read thoroughly in order to avoid making a mistake in operational procedure.</p>
-----------------------------------------------------------------------------------	-------------------------------------------------------------------------------------------------------------------------------------------------------------------------------------------

1. Preface

Thank you very much for your purchase of our product MinebeaMitsumi TYPE TORQUE TRANSDUCER .
 First of all , you will please check whether or not there is any damage done to the transducer in transit or the model of the unit delivered is as specified in the order sheet .
 If there are any doubtful or unknown points , be sure to contact the dealer or our sales office .

Refer to the catalogues or specifications for the specification of related models .

2. Outline

This unit is a torque transducer combining a torque detecting shaft which has been calibrated by sticking a strain gage and a rotary transformer taking out a signal from a rotary body non-contact. This torque transducer makes it possible to make measurement both kinds of static and dynamic torques. Furthermore, gears for detection of revolution have been built in. Therefore, fitting a revolution detector to this torque transducer makes it possible to make measurement of both torque value and rpm at the same time.



CAUTION

- Be sure to use this unit within the range of rated capacities .
- Be sure not to apply a voltage exceeding the maximum allowable applying voltage .
- Fit this unit , using hexagonal bolts (holed) The size of bolts to be used is mentioned in this text of instruction manual as well as specification . Selection of bolts shall be made in accordance with STRENGTH DIVISION 10.9 OR HIGHER OF JIS B 1051 .
- In the environment where screws and bolts tend to loosen easily , retighten them periodically or provide a detent thereto .
- In case this unit is fitted to medical treatment apparatuses or machines influencing human life , be sure to provide a protective circuit in preparation for the failure of function of this unit .
- In case this unit is used under special environmental conditions , be sure to consult with us before use .

3. Construction

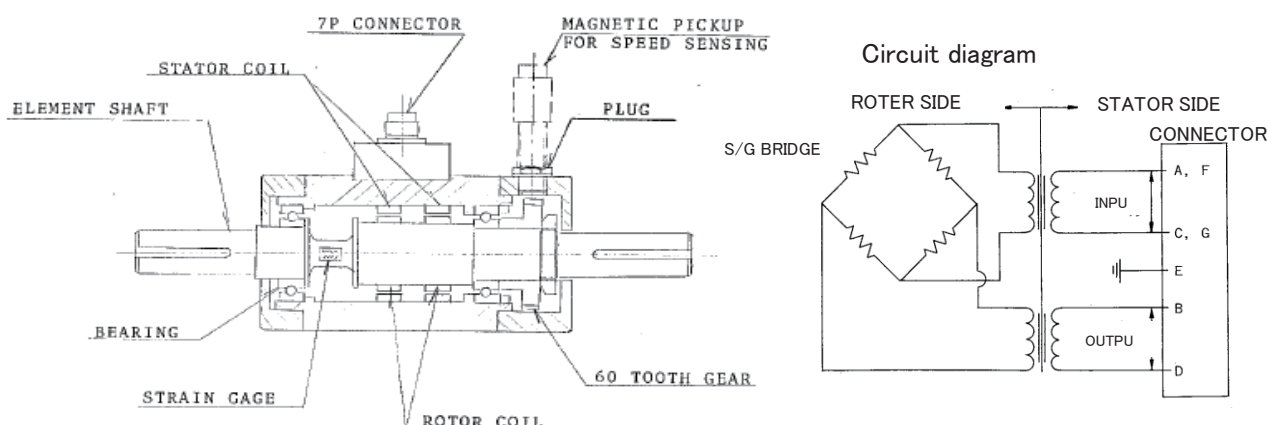

4. Fitting method

4-1. Selection of coupling

Jointing to the partner machine, be sure to use a flexible coupling, not making rigid coupling. Do not make such coupling as giving a bending load e.g. belt, chain etc.

As for coupling, be sure to select such a one which is light and good in rotating balance, referring to the chart for loading at shaft end. If the loading at shaft end is larger than an allowable value, there will be a possibility that injurious influence is exerted over torque accuracy by bending or increase in vibration at high speed revolution due to decrease in critical speed of shaft. Therefore, never use it.

4-2. Fitting method of coupling

The fitting method of coupling must be shrink fit. The hold diameter of coupling and tightening and tightening allowance of shaft diameter must be $0.5 \mu\text{m}$ per 1 mm of shaft dia.

The appropriate heating temperature is $120\text{--}150^\circ\text{C}$. If caught in the midway, stop the operation at once and disconnect it and then, check whether or not there is burr in the fitting part.

Returning the temperature of coupling and shaft to the normal temperature, measure the inner and outer diameters and key dimensions.

After finishing the fitting at normal position, cool it forcibly with compressed air and make the temperature conducted to the shaft to be as low as possible. Also, do not turn the shaft until the temperature of coupling and shaft to the normal temperature. If fitted as follows, the torque transducer will be damaged, centering will be wrong or revolving vibration will be generated.

Therefore, be sure to avoid doing so.

- ① Fitting with a gap coupling and shaft
- ② Contact of coupling and body (stator)
- ③ Forced pressing-in with a hammer or by press

4-3. Dynamic balance

If unbalance is caused in the key grooves of coupling, a trouble of generation of vibration will be caused. Therefore, dynamic balance must be taken by overall adjustment after combining torque transducer with a coupling.

4-4. Fitting method

As for the fitting method, make the side where a heavy load is applied (test piece side) to be a double bearings side. We recommend you to adopt the following fitting method.

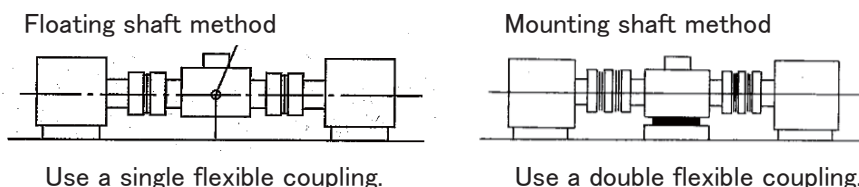

Whirl-stop method for floating

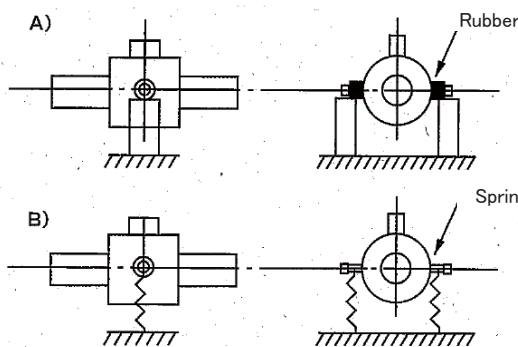

Use a rubber mount or spring.

Mount shaft baseplate

Exclusive baseplate(NRBS) is option.

Please assy torque transducer and baseplate(NRBS) by a companion bolt. (4 point)

Model	Torque transducer	Bolt
NRBS-1	TMNR-10NM/20NM/50NM/100NM/200NM	M5*1.6L
NRBS-2	TMNR-500NM/1KNM	M6*20L
NRBS-3	TMNR-2KNM/3KNM/5KNM	M8*25L
NRBS-4	TMNR-10KNM	M10*25L

4-5.

As illustrated in right side, with B side as reference, measure the parallel wrong alignment with ① dial gage and wrong angle with ② dial gage.

Then, adjust it in such a way that they become minimum. For adjustment, insert a liner between the fitting base at A side and make adjustment. At the same time, adjust the shaft to shaft dimensions ③. A side is torque transducer and B side, motor.

Allowable errors of ① ② and ③, maker's recommended values are fixed according to the coupling to be used. Basically speaking, set it based on the catalogue value of coupling. In the case of high speed revolution, deviation from direct coupling accuracy causes vibration. We recommend you to do as follows.

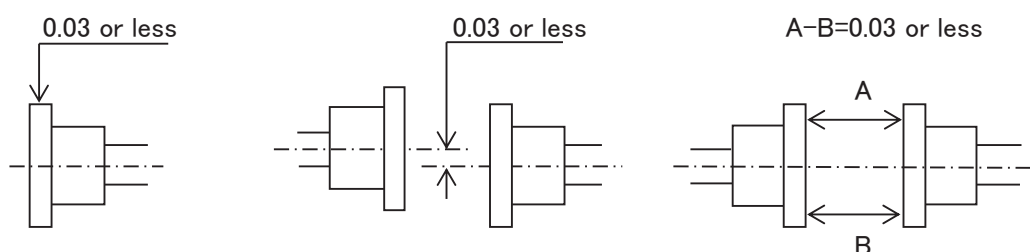
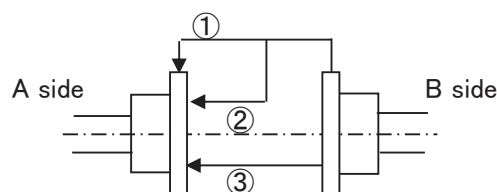

4-6. Important points for installation

- ① Selection of fitting bolts in accordance with the STRENGTH DIVISION 10.9 OR ABOVE OF JIS B 1051 shall be made .
- ② The fitting length of screws shall be longer than nominal diameters of screws .
- ③ Pedestal of fixing section of stator shall be fully rigid and flat .
- ④ Fit it in such a way that no dust or foreign matter enter it .
- ⑤ Proper tightening torques are shown in the following table .

NOMINAL DIA . OF BOLT	PROPER TIGHTENING TORQUE	
	(N·m)	
	(N·m)	(kgf·cm)
M 5	7.85	80
M 6	13.7	140
M 8	33.3	340
M 10	65.7	670

5. Preparation for measurement

5-1. Wiring

Connect the unit with a transmitter to be combined with an attached cable of this unit . Refer to the instruction manual for the details of transmitter (CSA-561) for the details .

5-2. Calibration

When no load is applied , adjust zero point and calibrate the output .

Refer to the instruction manual for the details of transmitter (CSA -561) .

As for torque outputs , when the rotor is twisted counterclockwise , a plus output will be outputted .

If you want to change the polarity , wire the + and - of the transmitter output cable reversely .

5-3. The installation of accessories: ROTARY DETECTOR MP-981(OPTION)

Please perform the following procedure to attach MP-981

- ① Remove a hexagon cover
- ② Screw a rotary detector(MP-981)
- ③ Screw calmly till touch the gear
- ④ Return half~one lap of screw
Half lap : gap is 0.5mm
One lap : gap is 1mm
(M16 × P1)
- ⑤ The Detector must be positioned properly with respect to the gear
Decide a direction in the range of 0.5-1mm gap

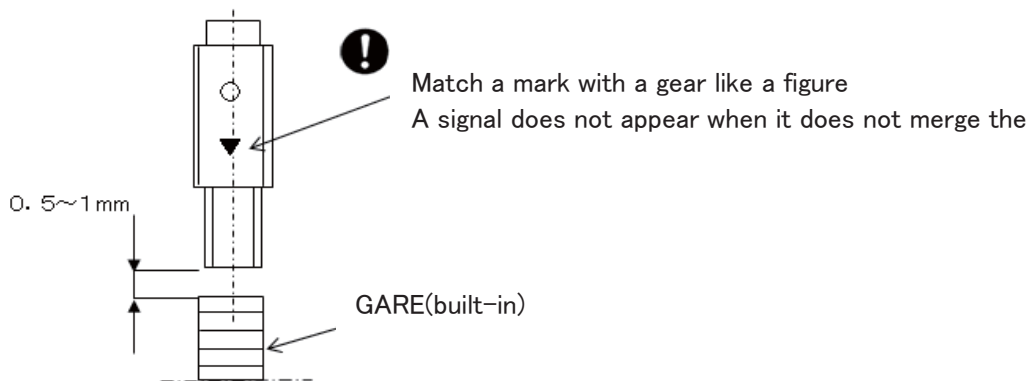

- ⑥ Lock it with a nut
Confirm that there is not contact with turning an axis by hand
- ⑦ After wiring, check the operation

5-4. Trial operation

Carrying out trial operation at a low speed , check and confirm that there are no abnormal output , sound , temperature , vibration etc . and carry out measuring operations .



6. Inspection and maintenance

Because using ZZ(shield)-type bearing, the bearing life is a grease exchange limit
The grease exchange limit changes by the use number of times
Please convert it than a lower list, and check it
Please ask it for bearing exchange repair

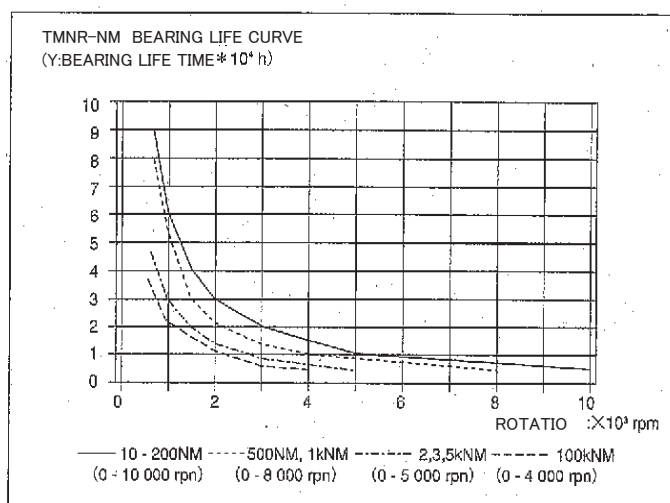



7. Cautions for use

- ① For official examination of this unit. Combined calibration has been made by dynamic strain gage in the test table and the specified cable length. Therefore, when using other type of dynamic strain gage than that in the test table and changed cable length, official examination must be conducted once again.
- ② Be sure to couple directly this unit and dynamic strain gage by an attached cable.
If other cable is used for direct coupling, there will arise such troubles as poor accuracy, generation of noise etc.
- ③ As it is a rotary body, be sure to fit a protective cover for prevention of flying away.
- ④ An unbalance caused by fitting of a coupling results in generation of vibration.
Therefore, dynamic balance must be adjusted overall after combining torque transducer and coupling etc.
- ⑤ If there should be impact load and vibration, a dynamic load caused by multiplying static load by acceleration will act on the torque transducer.
Therefore, the value calculated by taking acceleration into consideration shall not exceed the rated capacity of torque transducer.
- ⑥ If there is a possibility that an excess load acts on the torque transducer, provide a safety device against damage.
- ⑦ Provide full strength to the installing place.
- ⑧ Use the torque transducer at the ambient temperature within the temperature compensation range.
- ⑨ Be sure to avoid rapid change in temperature and direct exposure to heat.
- ⑩ Checking protection class, be sure to use the torque transducer in the environment free from formation of dew.
- ⑪ In the environmental condition where electric and magnetic fields are very intensive, noises will be generated in some times. Be sure to avoid using in such environment.
- ⑫ Transmission coil, luminous and light receiving elements tend to be damaged easily.
Therefore, full care must be taken when handling them.
- ⑬ Cable lead-out shall not be pulled forcibly or bent extremely. When carrying, do not suspend the stator section by holding the cable with hand.
- ⑭ In the vibrating environment, the cord shall be fixed in the vicinity of lead-out of cable and take a measure for prevention of vibration.
- ⑮ In the environment where screws and bolts tend to loosen, retighten periodically or provide a required detent thereto.
- ⑯ When fitting the torque transducer to medical treatment apparatuses or other machines influencing a human life, be sure to provide a protective circuit thereto in preparation for failure in function of the torque transducer.
- ⑰ Do not disassemble the torque transducer.
- ⑱ Avoid dropping an object on the unit or giving a shock thereto.
- ⑲ When disused, dispose of it, taking into full consideration environmental condition.

8. Countermeasures to be taken when abnormal

If an overload, RPM bending larger than allowable value or in a thrust direction should be applied, be sure to recalibrate in order to check whether or not it can be used normally.
If indication is unstable or abnormal, check whether or not connection with gages is correct or reliable or important points for use are observed and then, check the following points of torque transducer.

- ① With the CAL switch of transmitter, check whether or not the check values are normal.
- ② Check whether or not a change takes place when the rotor section is twisted with hand.
- ③ Check whether or not the output at the time of no loading (zero balance) is broken markedly.

If there is anything abnormal in the above values, contact with our company.

9 Reference data

9-1. TMNR-**NM mechanical property table

Model	10NM	20NM	50NM	100NM	200NM	500NM	1KNM	2KNM	3KNM	5KNM	10KNM
Technical spec.											
Inertia moment at rotor (kg·cm ²)	2.864	2.864	2.864	2.873	3.011	16.38	16.48	123.6	124.5	124.5	193.2
GD ² at rotor (kg·cm ²)	11.45	11.45	11.45	11.49	12.04	65.51	65.90	494.3	498.2	498.2	772.8
Torsional rigidity at rotor (kN·m/rad)	1.912	3.128	4.080	6.296	11.21	48.90	63.98	319.5	384.5	446.9	744.8
*1 Torsional inherent vibration number at rotor (kHz)	2.8	3.6	4.0	3.9	5.2	3.3	3.8	2.7	3.0	3.2	2.5
Mass at rotor (kg)	1.3	1.3	1.3	1.5	1.5	4.3	4.3	13.2	13.3	13.4	20.5
Rated torsional angle of rotor (°)	0.294	0.359	0.689	0.892	1.003	0.575	0.878	0.352	0.438	0.629	0.754
Max rpm (rpm)	10 000	10 000	10 000	10 000	10 000	8 000	8 000	5 000	5 000	5 000	4 000
*2 Allowable shaft end load (N)	9.807	14.71	14.71	29.42	34.32	49.03	98.07	245.2	294.2	441.3	980.7
Static allowable shaft end load (N)	9.807	29.42	49.03	98.07	196.1	490.3	980.7	1 470	1 961	2 942	4 903
*3 Static allowable shaft end thrust load (N)	98.07	98.07	98.07	98.07	98.07	294.2	294.2	490.3	490.3	490.3	490.3
Bearing used (P5)	6005ZZ	6005ZZ	6005ZZ	6005ZZ	6005ZZ	6008ZZ	6008ZZ	6014ZZ	6014ZZ	6014ZZ	6016ZZ
Total mass (kg)	3	3	3	3	3	7.5	7.5	21	21	21	32

Converted calculation to convention unit : 1 kgf = 9.80665 N

*1 Non coupling condition

*2 Value at maximum rpm. Refer to the shaft end load chart for the details.

*3 Please use it as a general rule not to put thrust load.

9-2. TMNR-**NM Shaft end load chart

