



***TORQUE TRANSDUCER***  
***TMNR-\*NME***

(for Torque Transducer)

**Instruction Manual**

**MinebeaMitsumi Inc.**

Sensing Device Business Unit

Read this instruction manual thoroughly prior to start use of this product.  
 Be sure to observe the notes and cautions mentioned in this text of inspection manual.  
 You will please file this manual in such a way that it is available anytime immediately whenever you want to refer to.

The following are the marks and symbols used in this inspection manual. The following are the marks and symbols for the matters which you must not do absolutely or to which you must pay full attention or you must refer to. Be sure to peruse the paragraphs marked with these marks and symbols.

	<p><b>CAUTION</b> If not observed , it will cause troubles of injury or damage done to properties or result in endangering a human life.  <b>DO NOT DO THE MATTERS MAKED WITH THIS MARK ABSOLUTELY.</b></p>
---	---

	<p>This mark shows the limitation or attention which you must pay when operating or working . Be sure to read thoroughly in order to avoid making a mistake in operational procedure.</p>
---	---

## 1. Preface

Thank you very much for your purchase of our product MinebeaMitsumi TYPE TORQUE TRANSDUCER .  
 First of all , you will please check whether or not there is any damage done to the transducer in transit or the model of the unit delivered is as specified in the order sheet .  
 If there are any doubtful or unknown points , be sure to contact the dealer or our sales office .

Refer to the catalogues or specifications for the specification of related models .

## 2. Outline

This unit is a torque transducer combining a torque detecting shaft which has been calibrated by sticking a strain gage and a rotary transformer taking out a signal from a rotary body non-contact. This torque transducer makes it possible to make measurement both kinds of static and dynamic torques. Adopting a dripping lubricating system has been adopted for bearings in order to improve high speed revolution performance and durability (Standard lubricating method for less than 3000 rpm is grease lubrication.) Furthermore, gears for detection of revolution have been built in. Therefore, fitting a revolution detector to this torque transducer makes it possible to make measurement of both torque value and rpm at the same time.



## CAUTION

- Be sure to use this unit within the range of rated capacities .
- Be sure not to apply a voltage exceeding the maximum allowable applying voltage .
- Fit this unit , using hexagonal bolts (holed ) The size of bolts to be used is mentioned in this text of inspection manual as well as specification . Selection of bolts shall be made in accordance with STRENGTH DIVISION 10.9 OR HIGHER OF JIS B 1051 .
- In the environment where screws and bolts tend to loosen easily , retighten them periodically or provide a detent thereto .
- In case this unit is fitted to medical treatment apparatuses or machines influencing human life , be sure to provide a protective circuit in preparation for the failure of function of this unit .
- In case this unit is used under special environmental conditions , be sure to consult with us before use .

### 3. Construction

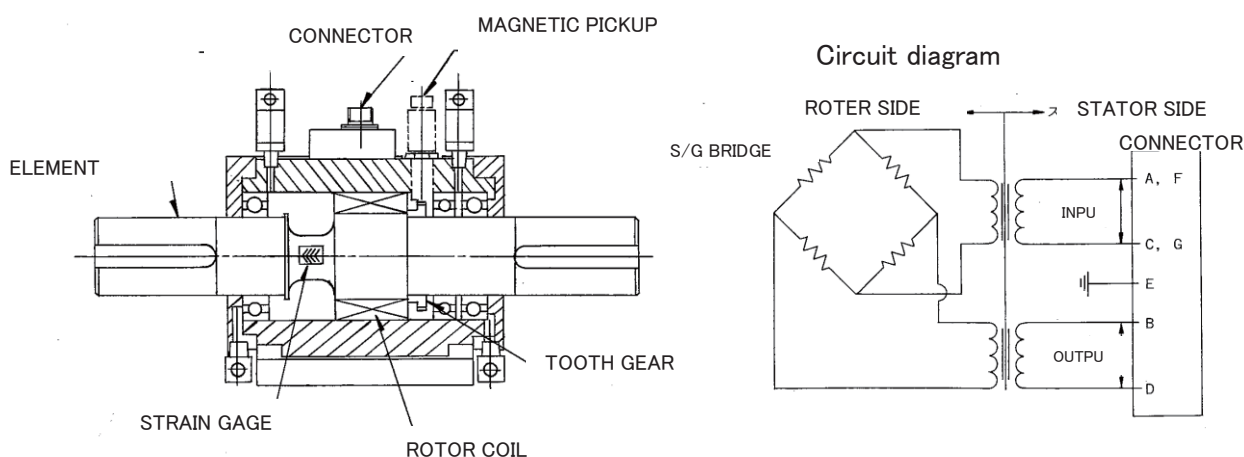

### 4. Fitting method

#### 4-1. Selection of coupling

Jointing to the partner machine, be sure to use a flexible coupling, not making rigid coupling.

Do not make such coupling as giving a bending load e.g. belt, chain etc.

As for coupling, be sure to select such a one which is light and good in rotating balance, referring to the chart for loading at shaft end. If the loading at shaft end is larger than an allowable value, there will be a possibility that injurious influence is exerted over torque accuracy by bending or increase in vibration at high speed revolution due to decrease in critical speed of shaft. Therefore, never use it.

4-2. Fitting method of coupling

The fitting method of coupling must be shrink fit. The hold diameter of coupling and tightening and tightening allowance of shaft diameter must be  $0.5 \mu\text{m}$  per 1 mm of shaft dia.

The appropriate heating temperature is  $120\text{--}150^\circ\text{C}$ . If caught in the midway, stop the operation at once and disconnect it and then, check whether or not there is burr in the fitting part.

Returning the temperature of coupling and shaft to the normal temperature, measure the inner and outer diameters and key dimensions.

After finishing the fitting at normal position, cool it forcibly with compressed air and make the temperature conducted to the shaft to be as low as possible. Also, do not turn the shaft until the temperature of coupling and shaft to the normal temperature. If fitted as follows, the torque transducer will be damaged, centering will be wrong or revolving vibration will be generated.

Therefore, be sure to avoid doing so.

- ① Fitting with a gap coupling and shaft
- ② Contact of coupling and body (stator)
- ③ Forced pressing-in with a hammer or by press

4-3. Dynamic balance

If unbalance is caused in the key grooves of coupling, a trouble of generation of vibration will be caused. Therefore, dynamic balance must be taken by overall adjustment after combining torque transducer with a coupling.

4-4. Fitting method

As for the fitting method, make the side where a heavy load is applied (test piece side) to be a double bearings side. We recommend you to adopt the following fitting method.

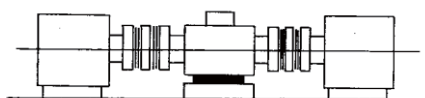

Use a double flexible coupling.

4-5. Aligning method

As illustrated in right side, with B side as reference, measure the parallel wrong alignment with ① dial gage and wrong angle with ② dial gage.

Then, adjust it in such a way that they become minimum. For adjustment, insert a liner between the fitting base at A side and make adjustment.

At the same time, adjust the shaft to shaft dimensions ③. A side is torque transducer and B side, motor.

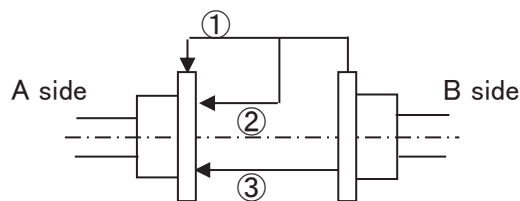

Allowable errors of ① ② and ③, maker's recommended values are fixed according to the coupling to be used. Basically speaking, set it based on the catalogue value of coupling. In the case of high speed revolution, deviation from direct coupling accuracy causes vibration. We recommend you to do as follows.

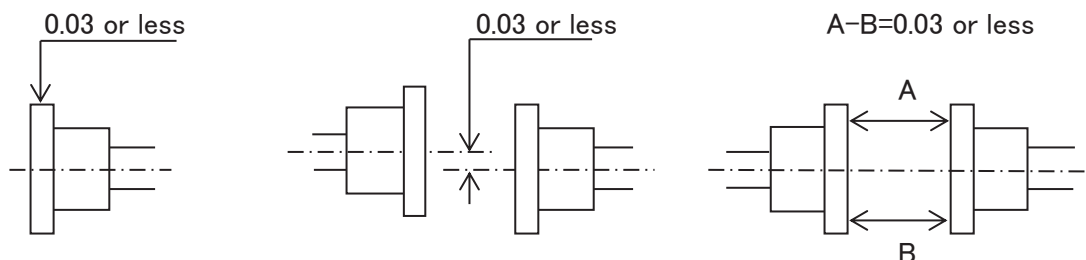



#### 4-6. Important points for installation

- ① Selection of fitting bolts in accordance with the STRENGTH DIVISION 10.9 OR ABOVE OF JIS B 1051 shall be made .
- ② The fitting length of screws shall be longer than nominal diameters of screws .
- ③ Pedestal of fixing section of stator shall be fully rigid and flat .
- ④ Fit it in such a way that no dust or foreign matter enter it .
- ⑤ Proper tightening torques are shown in the following table .

NOMINAL DIA . OF BOLT	PROPER TIGHTENING TORQUE (N·m)	
	(N·m)	(kgf·cm)
M 5	7.85	80
M 10	65.7	670
M 16	279	2850

#### 5. Preparation for measurement

##### 5-1. Wiring

Connect the unit with a transmitter to be combined with an attached cable of this unit .  
Refer to the instruction manual for the details of transmitter ( CSA-561 ) for the details .

##### 5-2. Calibration

When no load is applied , adjust zero point and calibrate the output .  
Refer to the instruction manual for the details of transmitter ( CSA -561 ) .  
As for torque outputs , when the rotor is twisted counterclockwise , a plus output will be outputted .  
If you want to change the polarity , wire the + and - of the transmitter output cable reversely.

##### 5-3. Fitting of accessories

###### (1) Earthing brush

When coupling directly with an electric motor etc, a large axial current (voltage) will run in the motor shaft depending on type of motor. Thus, noise will be caused in the signal of a torque transducer in some cases. It can be removed to some extent by LPF (low pass filter) of the dynamic strain gage. For removal of noise by more than 90%, the attached earthing brush must be placed on the coupling boss or fitted to any place on the revolving shaft before use.

The earthing brush for torque transducers composed of the following 2 places.

NAME: BRUSH HOLDER	TYPE: Gr 60
NAME: BRUSH	TYPE: Gr 61

###### ● Fitting method

- ① Prepare hardware for fitting an earthing brush. If installed on the coupling boss, be sure to use the attached brush adaptor (a crescent shaped hardware for fitting to the body).  
The brush adaptor may be fitted to either of single bearing side or double bearing side.  
If the abovementioned hardware is not used, use it by taking advantage of the thread of M18×P1.5 provided in the brush holder. Providing a screw hold of M18 or 18.5 dia or so through hold in the hardware, fix it with nut for fitting, The installing place must be located at coupling boss between motor and torque transducer or somewhere on the revolving shaft.
- ② Put a brush in the brush holder. Be sure to check and confirm that the brush can be moved smoothly against the inner cylinder of brush holder.

- ③ Installation to rotary shaft.  
Surface roughness of contact surface of brush must be less than 6S.  
Adjust the installation in such a way that the length of brush beyond brush holder is 3 mm.

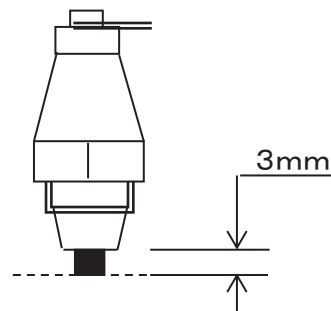

- ④ Cabling  
By taking advantage of the attached pressure terminal fit the cable wire.  
Install the cable wire must be provided at earthing line.

- (2) Rotary detector ( option )  
Refer to the attached instruction manual for the revolution detector for the fitting method and cabling method.

5-4. Confirmation of lubrication

In the case of dripping lubrication type, be sure to supply clean oil in the following manner.

- ① Kind of oil : FBK turbine 32 ( Sinnihon Petroleum Co.)
- ② Dripping quantity :  
Continuous dripping 60 drops ± 10 drops / minute  
( at normal temperature )  
Use of a dripping device makes it possible to adjust dripping quantity by means of a needle valve provided at the torque transducer.

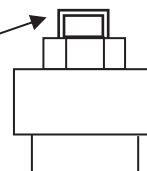

**【NOTES】**  
Select such a lubricating pump as possible to use under the abovementioned condition.  
If oil of which viscosity is different is used (other than 32) trouble will be caused. Therefore, do not use it absolutely.

5-5. Trial operation

Carrying out trial operation at a low speed , check and confirm that there are no abnormal output , sound , temperature , vibration etc . and carry out measuring operations .

6. Inspection and maintenance

6-1. Dripping lubrication type

If used, by circulating lubricating oil between torque transducer and lubricating pump, exchange lubricating oil for fresh one every 2500 total service hours.

6-2. Grease lubrication type

As for grease lubrication type, it is required to replenish grease thereto, periodically.

- ① Kind of grease : ALBANIYA NO.2
- ② Replenishing time of grease : Every 2000 total service hours
- ③ Replenishing quantity of grease : 500,1K,2KNME abt 35 g /bearing  
3KNME abt 45 g /bearing  
5KNME abt 55 g /bearing

Replenishing operation shall be carried out from grease nipples (R1/8 pin type) by a grease gun while operating (while revolving).



**【NOTES】**  
Different grease is no good.  
If replenishing quantity of grease is too much, much bearing heat will be generated.

## 6-3. Earthing brush

The earthing brush is made of carbon. Therefore, it wears by abrasion. If the length of brush is shorter than 10 mm, exchange it. Exchanging parts (brush Gr61) are separately priced. For reference, refer to the following simple calculation equation for the criterion for exchange time.

$$\text{Exchange time(h)} = \frac{1.13 \times 10^{11}}{S \text{ (mm)} \times 60 \times \text{Revolving speed (rpm)}}$$

S: Circumference length of contact revolution part

Calculation example:

Installing on the coupling boss of outer dia. 100, in case used at 5000 rpm

$$\frac{1.13 \times 10^{11}}{S \text{ (mm)} \times 60 \times \text{Revolving speed (rpm)}} = 1198 \text{ hours}$$



## 7. Cautions for use

- ① For official examination of this unit. Combined calibration has been made by dynamic strain gage in the test table and the specified cable length. Therefore, when using other type of dynamic strain gage than that in the test table and changed cable length, official examination must be conducted once again.
- ② Be sure to couple directly this unit and dynamic strain gage by an attached cable. If other cable is used for direct coupling, there will arise such troubles as poor accuracy, generation of noise etc.
- ③ As it is a rotary body, be sure to fit a protective cover for prevention of flying away.
- ④ An unbalance caused by fitting of a coupling results in generation of vibration. Therefore, dynamic balance must be adjusted overall after combining torque transducer and coupling etc.
- ⑤ If there should be impact load and vibration, a dynamic load caused by multiplying static load by acceleration will act on the torque transducer. Therefore, the value calculated by taking acceleration into consideration shall not exceed the rated capacity of torque transducer.
- ⑥ If there is a possibility that an excess load acts on the torque transducer, provide a safety device against damage.
- ⑦ Provide full strength to the installing place.
- ⑧ Use the torque transducer at the ambient temperature within the temperature compensation range.
- ⑨ Be sure to avoid rapid change in temperature and direct exposure to heat.
- ⑩ Checking protection class, be sure to use the torque transducer in the environment free from formation of dew.
- ⑪ In the environmental condition where electric and magnetic fields are very intensive, noises will be generated in some times. Be sure to avoid using in such environment.
- ⑫ Transmission coil, luminous and light receiving elements tend to be damaged easily. Therefore, full care must be taken when handling them.
- ⑬ Cable lead-out shall not be pulled forcibly or bent extremely. When carrying, do not suspend the stator section by holding the cable with hand.
- ⑭ In the vibrating environment, the cord shall be fixed in the vicinity of lead-out of cable and take a measure for prevention of vibration.
- ⑮ In the environment where screws and bolts tend to loosen, retighten periodically or provide a required detent thereto.
- ⑯ When fitting the torque transducer to medical treatment apparatuses or other machines influencing a human life, be sure to provide a protective circuit thereto in preparation for failure in function of

the torque transducer .

- ⑰ Do not disassemble the torque transducer .
- ⑱ Avoid dropping an object on the unit or giving a shock thereto .
- ⑲ When disused , dispose of it , taking into full consideration environmental condition .

#### 8. Countermeasures to be taken when abnormal

If an overload , RPM bending larger than allowable value or in a thrust direction should be applied .  
be sure to recalibrate in order to check whether or not it can be used normally .

If indication is unstable or abnormal , check whether or not connection with gages is correct or reliable or important points for use are observed and then , check the following points of torque transducer .

- ① With the CAL switch of transmitter , check whether or not the check values are normal .
- ② Check whether or not a change takes place when the rotor section is twisted with hand .
- ③ Check whether or not the output at the time of no loading ( zero balance ) is broken markedly .

If there is anything abnormal in the above values , contact with our company .

#### 9. Reference data

##### 9-1. TMNR-\*\*NME mechanical property table

Technical spec.		Model	500	1K	2K	3K	5K
			NME	NME	NME	NME	NME
	Inertia moment at rotor	(kg·cm <sup>2</sup> )	63.35	63.55	63.74	143.0	193.2
	GD <sup>2</sup> at rotor	(kg·cm <sup>2</sup> )	253.4	254.2	255.0	572.0	772.8
	Torsional rigidity at rotor	(kN·m/rad)	72.12	125.8	177.7	309.1	513.6
*1	Torsional inherent vibration number at rotor	(kHz)	1.700	2.400	3.000	2.900	2.700
	Mass at rotor	(kg)	10.5	10.5	10.5	16.5	21
	Rated torsional angle of rotor	(°)	0.390	0.446	0.632	0.545	0.547
	Max rpm	(rpm)	10000	10000	10000	8000	6000
*2	Allowable shaft end load	(N)	34.32	88.26	122.6	215.7	980.7
	Static allowable shaft end load	(kN)	0.490	0.981	1.961	2.942	4.903
	Static allowable shaft end thrust load	(kN)	1.961	1.961	1.961	1.961	1.961
	Bearing used (class P5)	Single side	6212	6212	6212	6214	6216
		Double side (CDB)	7212	7212	7212	7214	7216
	Total mass	(kg)	40	40	40	68	86

Converted calculation to convention unit : 1 kef = 9.80665 N

\*1 Non coupling condition

\*2 Value at maximum rpm. Refer to the shaft end load chart for the details.



9-2. TMNR-\*\*NME Shaft end load chart

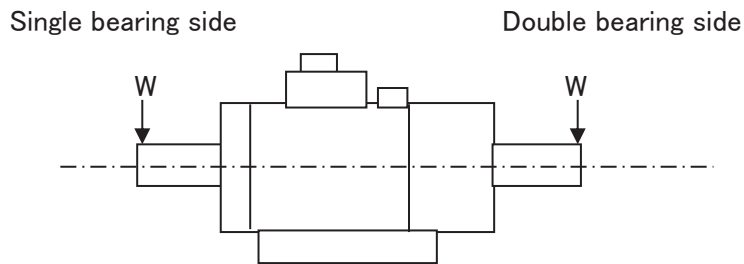

The graph shows the values when the condition is as above. But, the shaft end load at single bearing side exerts over accuracy of torque. Therefore, it is desired to use less than the following.

- 500NME : 34.32 N {3.5 kef}
- 1KNME : 88.26 N {9 kef}
- 2KNME : 122.6 N {12.5 kef}
- 3KNME : 215.7 N {22 kef}
- 5KNME : 980.7 N {100 kef}

If exceeding the abovementioned, arrangements must be made separately.

