

Minebea

***Torque Transducer
TMHSB***

Instruction Manual

EN294-1860B

Introduction

Thank you for purchasing our TMHSB Torque Transducer.

This instruction manual describes how to operate the device, as well as noteworthy points. Note that handling or operating the device incorrectly may result in malfunctions. Read this manual thoroughly before use for safety and optimal results.

Keep this instruction manual in a location where it is readily accessible to end users.

Overview

This equipment measures both static and dynamic torque using a thin-flange, bearing-free torque transducer that combines a torque detector flange calibrated by attaching a strain gage and an optical transformer that acquires signals optically, without making contact with the rotor.

Features include high precision, high stiffness, improved fatigue resistance and improved long-term consistency. The stator antenna has a split configuration to facilitate mounting and detachment.

Pictograms and Conventions Used in This Manual

This manual uses the following pictograms to indicate actions to avoid at all times, aspects requiring caution, and other noteworthy matters.

Be sure to read the descriptions provided alongside these pictograms.



Warning

This indicates circumstances in which incorrect handling may result in death or serious injury to users.

Avoid the actions described here at all times.



Caution

This indicates circumstances in which incorrect handling may result in injury to users or damage to property.



This indicates operating or procedural precautions or restrictions. Be sure to read the details provided here to avoid incorrect operations.

Safety Precautions

Please be sure to read this manual before attempting to use the equipment.

Warning

Be sure to use the equipment within its rated operating capacity range.

Warning

Impact loads or vibrations will subject the torque transducer to dynamic loads consisting of the static load multiplied by the acceleration. Make sure the value (taking acceleration into account) does not exceed the rated capacity of the torque transducer.

Warning

Install safety devices to prevent damage if excessive loads on the torque transducer are likely.

Warning

This is a rotating part. Keep a protective cover fitted at all times to keep materials from flying out.

Warning

Use the following bolts.

- Strength: JIS B 1051 strength classification of at least 12.9
- Type, size: As indicated in specifications

Warning

Confirm that the rotor and stator serial numbers match.
Mismatched parts may affect/impede operations or cause incorrect torque output values.

Warning

Confirm that the wiring is correctly connected before attempting to use the equipment. Incorrect wiring of the equipment may lead to incorrect measurements, equipment malfunctions, damage to peripheral equipment, and serious accidents.

Warning

Do not disassemble the torque transducer.

**Caution**

Make sure that only one connector on either side of the stator is used at any given time. You may connect one cable to either side to suit the installation configuration. However, do not connect cables to both sides at the same time.

**Caution**

Take care when handling the transmission coil, photoemitters, and sensor window. These parts are especially delicate.

**Caution**

Avoid bending excessively or pulling the cable outlet with excessive force. Do not hang the stator by grasping the cable when carrying it.

**Caution**

If used where vibrations occur, secure the cable near the cable outlet to prevent vibrations.

**Caution**

In environments where the screws may loosen, either make sure the screws are retightened periodically or take appropriate locking precautions.

**Caution**

Altering the settings while carrying out measurements using the equipment may result in incorrect measurements, equipment malfunctions, and damage to peripheral equipment.

**Caution**

Protect the equipment from impact or shock—for example, impact or shock caused by striking against other objects. Impact or shock may damage the product and lead to failures in the electrical circuits.

1. Installation Location

Warning

Install in a location where temperature and humidity conditions are within the ranges described below.

- Environmental temperature: 0 °C to 60 °C
- Environmental humidity: 85% RH or less (Non-condensing)

Warning

To minimize the risk of unforeseen accidents, avoid installing equipment in the following locations.

- Avoid locations exposed to infrared light from sunlight, incandescent lamps, or the like. Exposure to extraneous infrared light may cause malfunctions.
- Use a protective cover to shield the equipment in areas exposed to infrared light.
- Avoid use in damp locations.
- Do not install in locations with weak floor strength. Vibration may cause damage.
- Avoid use where the atmosphere contains excessive dust or particles.
- Avoid use where the atmosphere contains corrosive gases or salt.
- Do not install in locations subject to sudden temperature or humidity fluctuations.
- Do not install close to equipment that generates magnetic or electromagnetic radiation. Electromagnetic interference may result in noise.
- Do not install in locations subject to the effects of radioactivity or radiation.
- Do not install in locations such as laboratories where there is a risk of chemical reactions.

2. Power Supply

Warning

**Turn off power before connecting or disconnecting cables.
Connecting/disconnecting cables while power is on may result in electric shock or equipment damage.**

Warning

**Before turning on power, confirm that the power supply meets equipment specifications.
Contact us if the specifications do not match. Using an unconfirmed power supply may result in electric shock or equipment damage.**

Warning

**Always ground the equipment.
Failure to connect the grounding cable may result in electric shock or equipment malfunctions.**

3. Compatible standards

This equipment conforms to the following standards:

- EN61326-1: 2013
“Electrical equipment for measurement, control, and laboratory use - EMC requirements”
“Immunity requirements for equipment intended to be used in industrial locations”
- EN50581: 2012
“Technical documentation for the assessment of electrical and electronic products with respect to the restriction of hazardous substances” (RoHS Directive)



Caution

The equipment conforms to EN61326-1 when the following conditions are met.

- **Shielding**
Use a dedicated cable and ground the shield.
- **Grounding**
This equipment shall be grounded based on Type D single grounding using a protective ground connector.

Revision History

Date	Manual No.	Revision reason (details)
July 2018	DRW. No. EN294-1860	First edition, ROM ver. 1.000
Mar.2019	DRW. No. EN294-1860A	Due to ECN FN19-0138 Add description of 10KNM to 3-2, 3-3, 8-1, 8-2
April.2020	DRW. No. EN294-1860B	Due to ECN FN20-0180 Added 7-1-1 item "Group delay times,Filter settings" Added 7-3. The voltage output changes the group delay time depending on the setting of the low-pass filter. For details, please refer to 8-4 output signal (voltage) in 8. Specifications. Added 8-4 item "Group delay times,Filter settings"

Contents

INTRODUCTION	I
OVERVIEW	I
PICTOGRAMS AND CONVENTIONS USED IN THIS MANUAL	I
SAFETY PRECAUTIONS	II
1. Installation Location.....	IV
2. Power Supply.....	IV
3. Compatible standards.....	V
REVISION HISTORY	VI
CONTENTS	VII
1. PART NAMES AND FUNCTIONS	1
2. CONFIGURATION	3
3. MOUNTING PROCEDURE	5
3-1. Typical mounting configuration.....	5
3-2. Mounting flange restrictions.....	5
3-3. Mounting procedure and precautions.....	6
4. CONNECTIONS	9
4-1. Wiring precautions.....	9
4-2. Dedicated cable (CAC-176D-*M, sold separately).....	9
4-3. Stator connector pin assignment.....	10
4-4. External control output connections.....	11
4-5. External control input connections.....	12
4-6. Torque voltage output connections.....	13
4-7. Torque frequency output connections.....	13
4-8. Power and ground connections.....	13
5. TESTING OPERATION	14
5-1. Status display.....	14
5-2. Checking output.....	14
5-3. Running-in operation.....	14
6. CALIBRATION	15
7. FUNCTIONS	16
7-1. Analog voltage output.....	16
7-2. Torque frequency output.....	18
7-3. Filter settings.....	18
7-4. Autozero.....	19
7-5. Symmetry correction.....	19
7-6. Polarity switching function.....	19
7-7. External control input/output.....	20
7-8. CHECK.....	21
7-9. Calibration data selection.....	21
7-10. Calibration prohibited.....	21
7-11. Error log.....	21
7-12. Function list.....	22
7-13. Error list.....	24
8. SPECIFICATIONS	25
8-1. Specifications.....	25
8-2. Mechanical characteristics (rotor).....	25
8-3. Power.....	26
8-4. Output signals (voltage).....	26
8-5. Output signals (frequency).....	26

8-6. Adjustment of output voltage	26
8-7. Status display LED.....	27
8-8. Interfaces	27
8-9. General specifications	27
8-10. Accessories.....	27
8-11. Options.....	27
9. WARRANTY.....	28
9-1. Warranty.....	28
9-2. Repairs.....	28
10. COMPONENT SERVICE LIVES.....	28
11. MAINTENANCE AND INSPECTIONS.....	29
12. TROUBLESHOOTING	29

1. Part Names and Functions

The torque transducer consists of a rotor and stator.

Power is supplied from the stator to the rotor by a noncontact coil.

Torque applied to the rotor flange is detected by a strain gage in the rotor.

The electronic circuit in the rotor converts torque into a digital signal, making the photoemitters (LEDs) along the rotor's outer circumference flash.

Rotor light entering the sensor window on the stator is converted into a voltage by the photoreceptor and electronic circuit.

Two torque values are produced at the same time: stator frequency output and analog voltage output.

★ Frequency output: Use the values on the certificate of analysis to convert to torque values.

★ Analog voltage output: Corrected voltage values are produced from calibration data recorded in the stator.

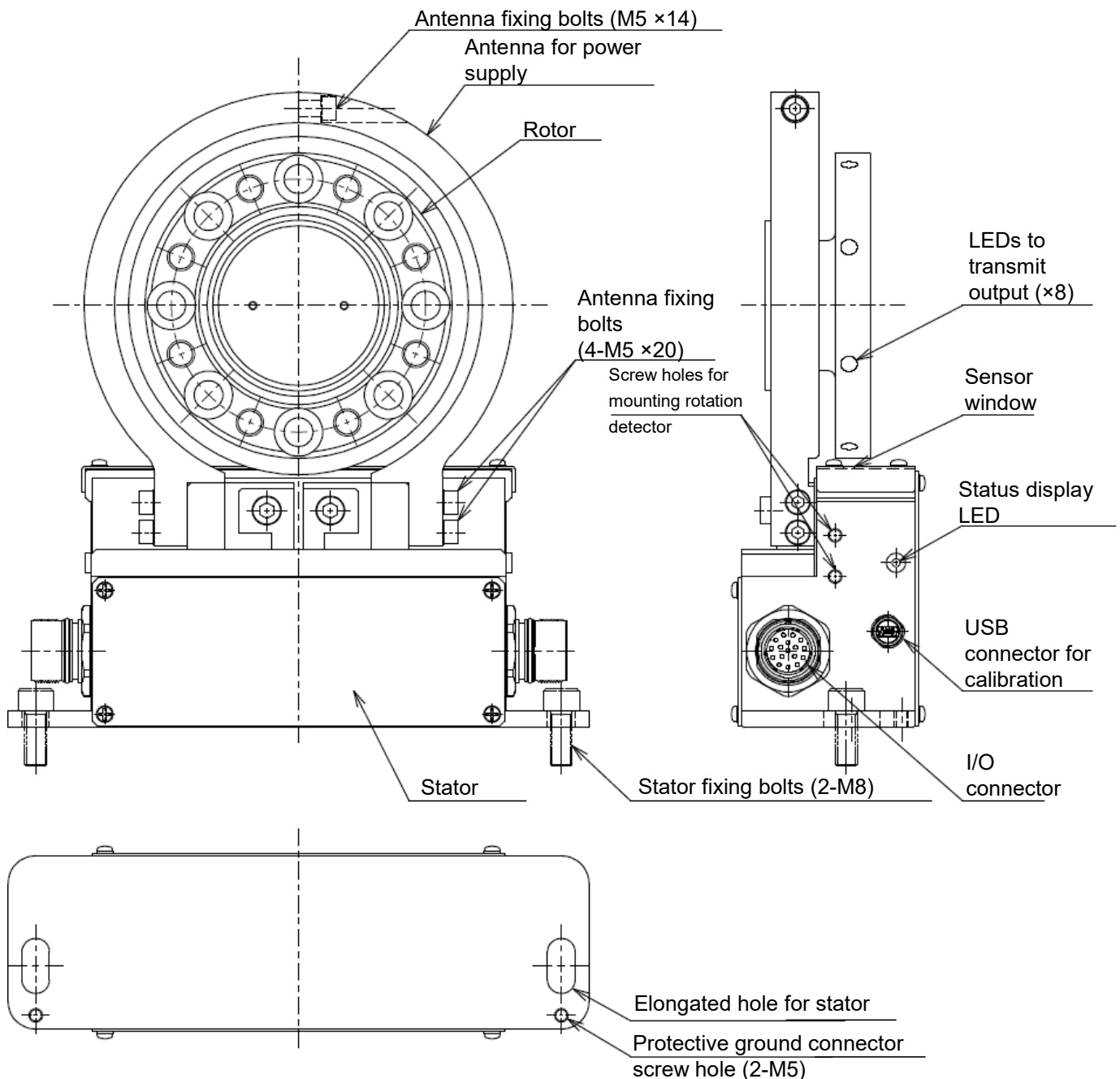

Name	Function
I/O connector	I/O connector for connecting power, a digital multimeter, frequency counter, and so on. The same signals are transferred through connectors on either side. (Both cannot be used at the same time.)
USB connector for calibration	USB connector for calibrating the torque transducer or changing settings. The same signals are transferred through connectors on either side. (Both cannot be used at the same time.)
Status display LED	Shows torque transducer status. (Same display on the LEDs on the left and right) Lit in green: Normal status Flashing green: Low light level Lit in red: Insufficient light level Flashing red: Fault has occurred
Protective ground connector screw hole	Screw hole for connecting the grounding wire. Connect this to ground to eliminate noise effects such as static electricity. Do not connect any wires other than the grounding wire. Connect at one of the two positions.



Caution

Caps are included for the I/O connector and USB connector for calibration. Make sure the connectors are covered with caps at all times when not in use.

2. Configuration

TMHSB torque transducers can be used in the following configurations.

Torque output consists solely of frequency output and voltage output.

Calibration is performed using a connected computer.

★ For calibration instructions, refer to the calibration software manual.

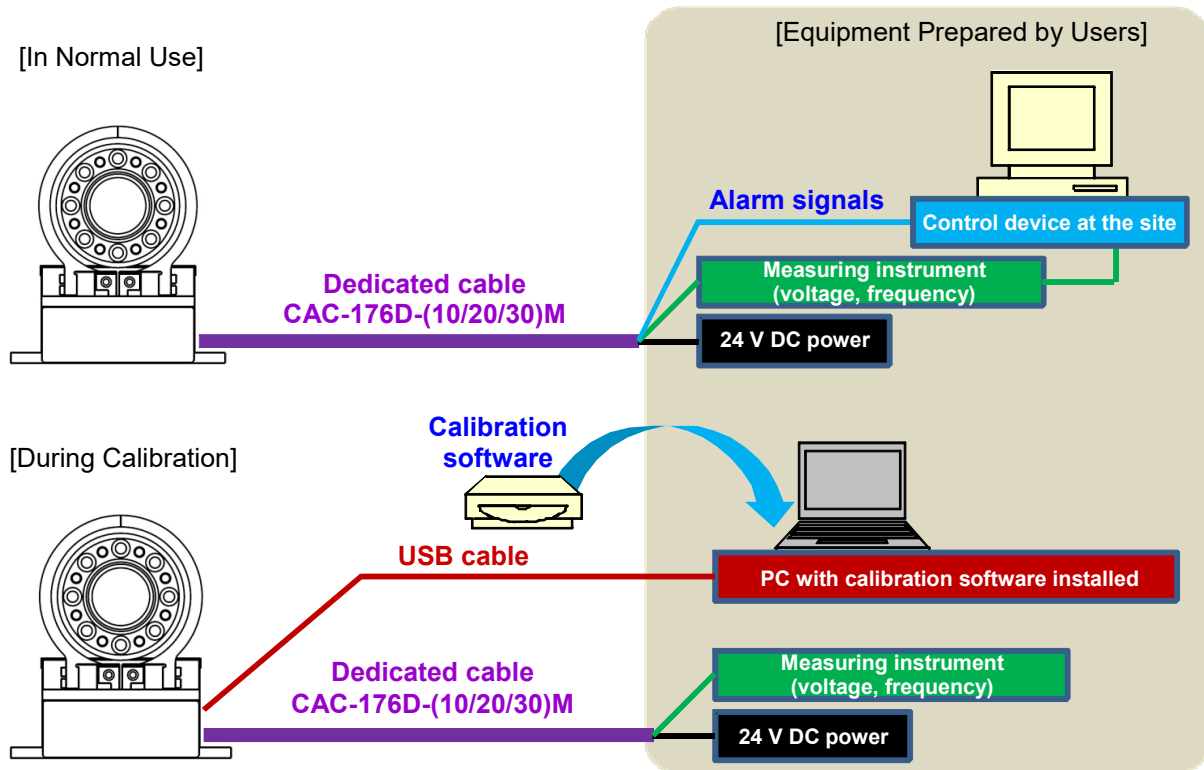

Caution

Dedicated CAC-176D-**M cables are required when using TMHSB transducers. These differ from the cables used with the TMHS and TMHSA transducers.

Additionally, to detect the rotating speed, use in conjunction with an optional rotary speed detector (RPM-**-**)

The rotary speed detector consists of the following components.

- Detecting gear
- Connecting bolt
- Sensor (MP-9820)
- Sensor mounting fixture
- Mounting jig

A 12 V DC power supply must be provided by the user for the sensor.

The output from the sensor consists of a pulse signal generated each time the detecting gear (120 teeth for 100NM to 3KNM and 240 teeth for 5KNM to 10KNM) passes.

The user is responsible for converting this into rotation speed.

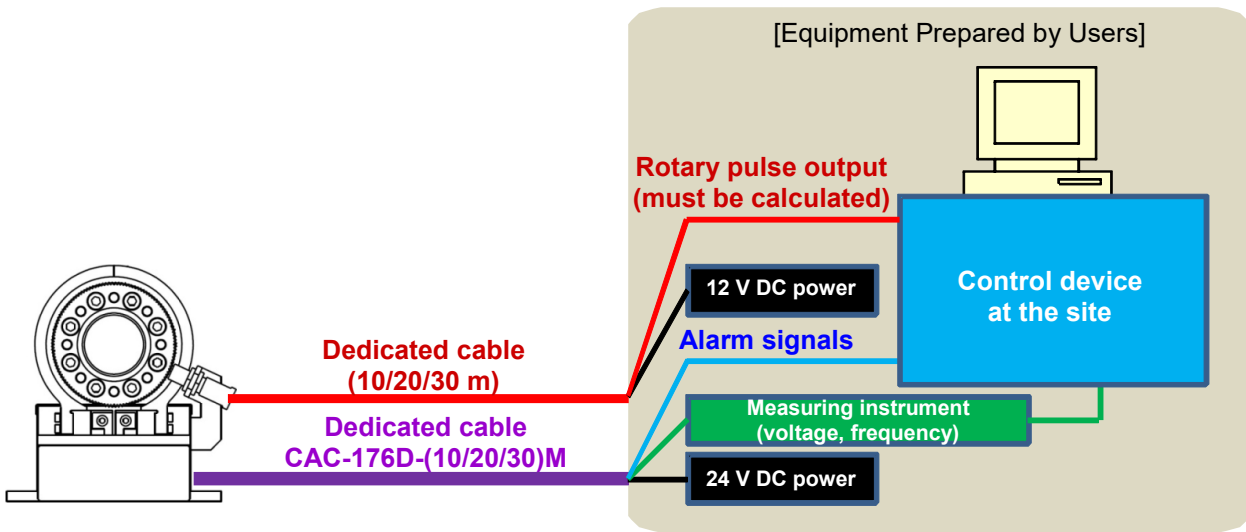

3. Mounting Procedure

3-1. Typical mounting configuration

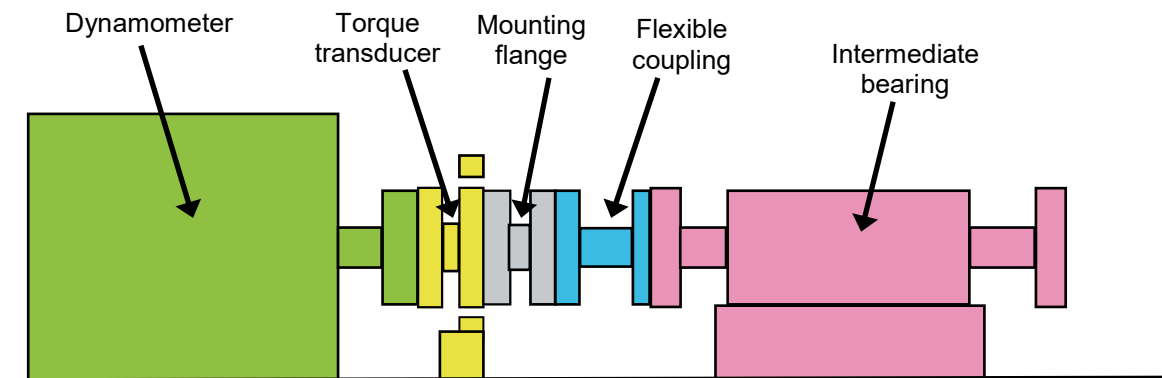

3-2. Mounting flange restrictions



Caution

Any metal objects near the coil around the rotor and the ring-shaped stator antenna may interfere with power supply and cause a zero shift or drift in output values. Refer to the following information when determining the suitable shape and material of the mounting flange and protective cover.

- (1) Dimension α (Mounting flange outer diameter)
 - Measure to the edge of the torque transducer rotor
 - Maximum diameter of 104 mm for TMHSB-100NM to 300NM
 - Maximum diameter of 111 mm for TMHSB-500NM and 1KNM
 - Maximum diameter of 153 mm for TMHSB-2KNM and 3KNM
 - Maximum diameter of 182 mm for TMHSB-5KNM
 - Maximum diameter of 226 mm for TMHSB-10KNM
- (2) Dimension β (Distance from rotor flange edge face)
 - At least 8 mm for A type mounting flange configuration (diameter extends to rotor)
 - At least 15 mm for B type mounting flange configuration (diameter extends to antenna)
- (3) Dimension γ (Distance from stator antenna to protective cover, etc.)
 - At least 10 mm from the outer diameter of the antenna

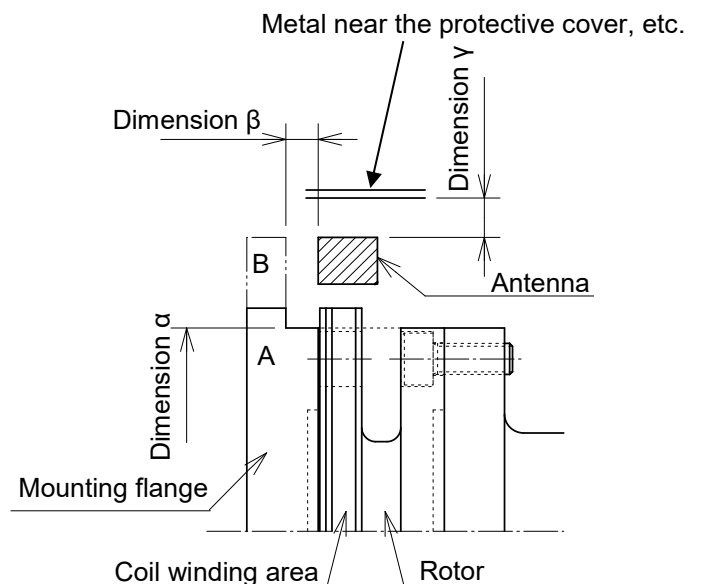

3-3. Mounting procedure and precautions

- (1) Use fixing bolts with a JIS B 1051 strength classification of at least 12.9.
- (2) Make sure the length of the threaded screw shaft is at least equal to the nominal screw diameter.
- (3) Make sure the stator clamping base is level and offers adequate stiffness.
- (4) Confirm that the rotor and stator serial numbers match.
- (5) Clean the surfaces that make contact with the rotor flange and engaged parts by wiping them with ethanol or similar solvent.



Any remaining anticorrosive agent applied at the time of shipment may cause slipping, resulting in a zero shift in output values.

- (6) Be careful to avoid trapping debris and foreign matter inside when mounting.
- (7) Mount the rotor in the following sequence:
 - 1) Using an initial tightening torque of 1/4, tighten in the order A→B→C→...→H.
 - 2) Using an initial tightening torque of 1/2, tighten in the order A→B→C→...→H.
 - 3) When using the final tightening torque, tighten in the order A→B→C→...→H.

Capacity	Bolt size	1/4 tightening torque (N·m)	1/2 tightening torque (N·m)	Tightening torque (N·m)
100NM–300NM	M8	11	21	42
500NM, 1KNM	M10	23	45	90
2KNM, 3KNM	M12	38	75	150
5KNM	M14	55	110	220
10KNM	M16	85	170	340

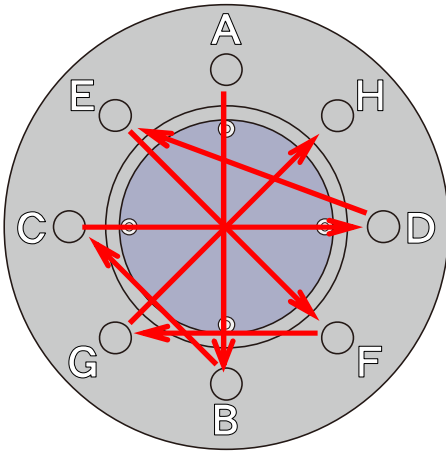

- (8) Be careful to avoid damaging the coil around the rotor.
- (9) After mounting, remove the green protective tape on the LEDs.

[Detailed view of rotor attachment]

100NM-500NM

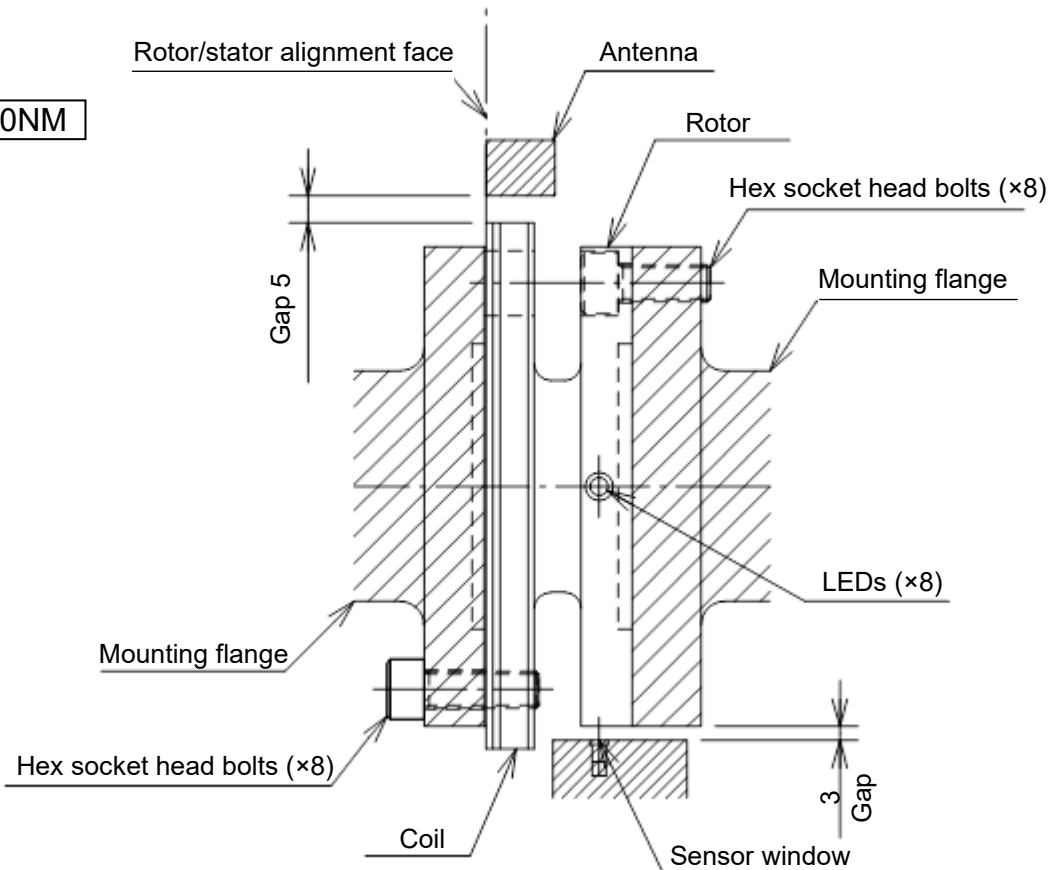

1KNM-10KNM

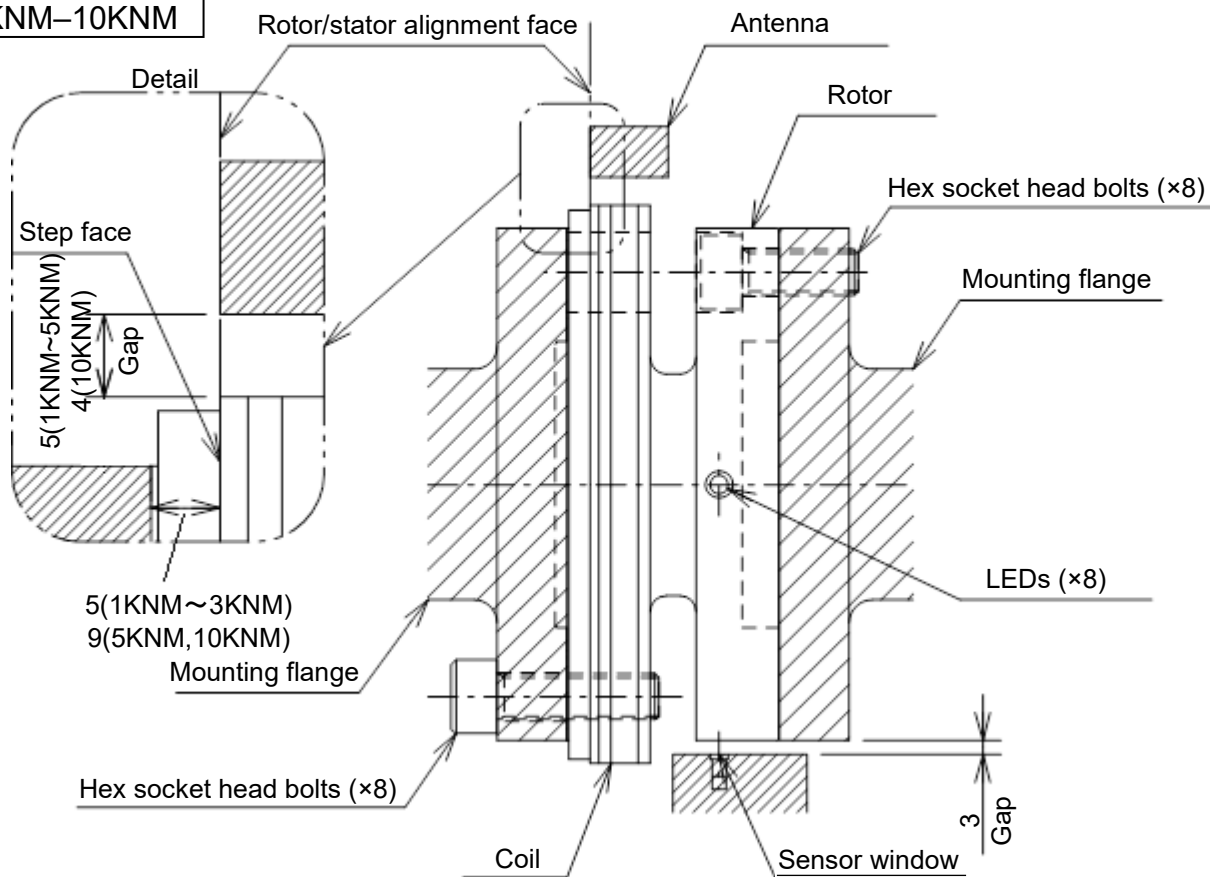

(10) Mount the stator in the following sequence:

- 1) Remove the three antenna fixing bolts shown below to separate the antenna.
Be careful to avoid losing the bolts and flat spring washers after removal.
- 2) Place the rotor inside before reassembling the separated antenna.
Insert the flat spring washers and tighten to a torque of 8 N·m.



Bolts that are too loose pose the risk of inconsistent output and may generate heat and cause alarms.

3) Align the stator with the rotor.

Align as shown in [Detailed view of rotor attachment.]

Mounting precautions

Ensure that the rotor LEDs are aligned with the stator sensor window.

Ensure a gap of 3 mm ±0.5 mm between the stator sensor cover and the rotor.

Ensure an even gap of 5 mm ±1 mm (10KNM:4mm ±1mm) between the rotor and the antenna.

4) Secure with stator fixing bolts.

Attach using M8 bolts with plain/spring washers at two locations and tighten to a torque of 34 N·m.



Never loosen any bolts other than those specified for separating the antenna. This may cause power transmission to become unstable, resulting in unstable operation.

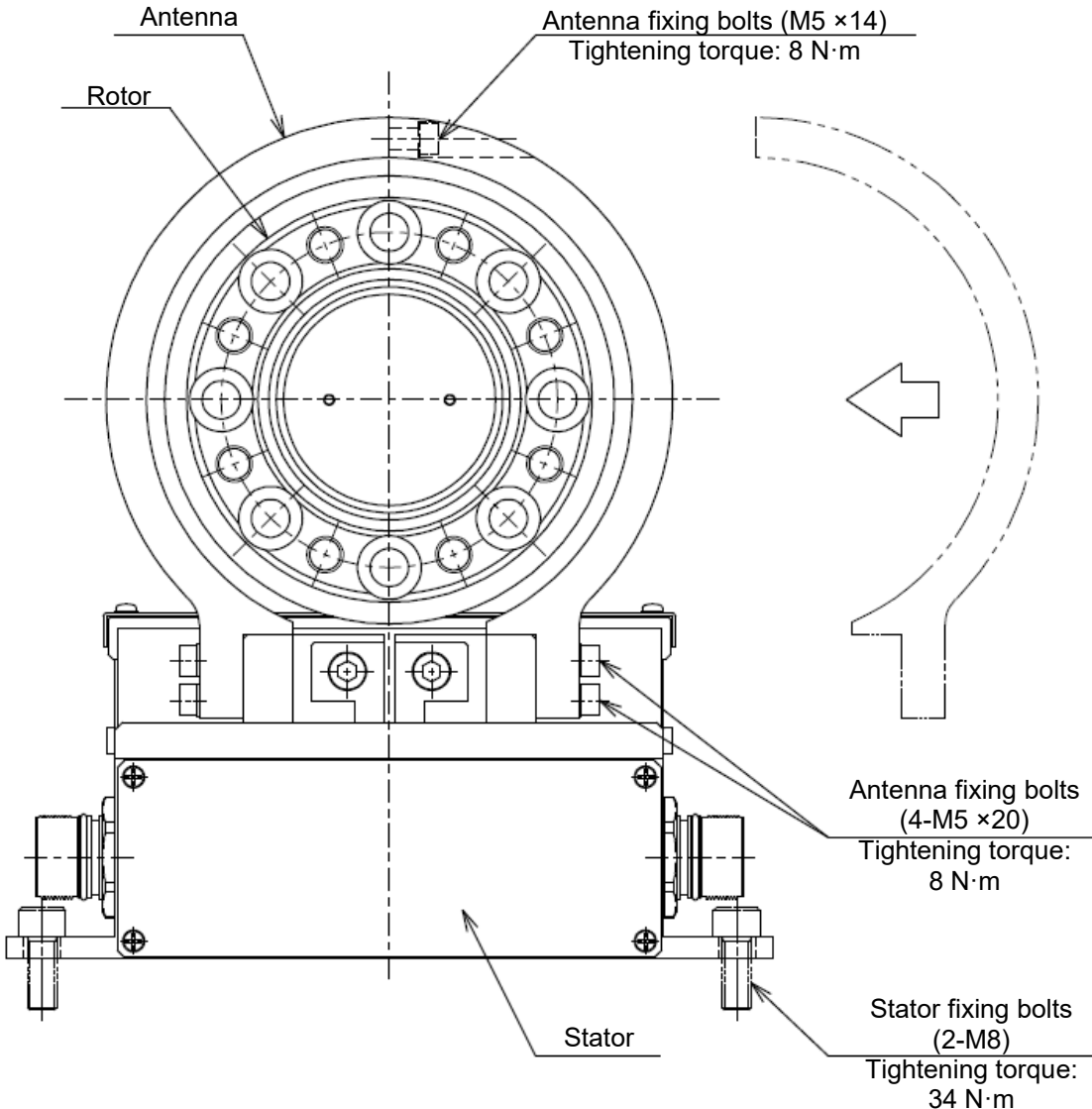

4. Connections

4-1. Wiring precautions



Caution

- Always turn off power before connecting or disconnecting the equipment.
- Do not turn on power until all installation work is complete.
- There is no ON/OFF switch on the unit itself.
- Keep cables connected to the unit as far away as possible from sources of noise such as power lines or control interfaces
- The conduit should house exclusively cables connected to the equipment itself. Avoid joint use with other lines in the conduit.
- Always ground the equipment. Use Type D single grounding. Do not share a ground with the power supply system.

4-2. Dedicated cable (CAC-176D-*M, sold separately)

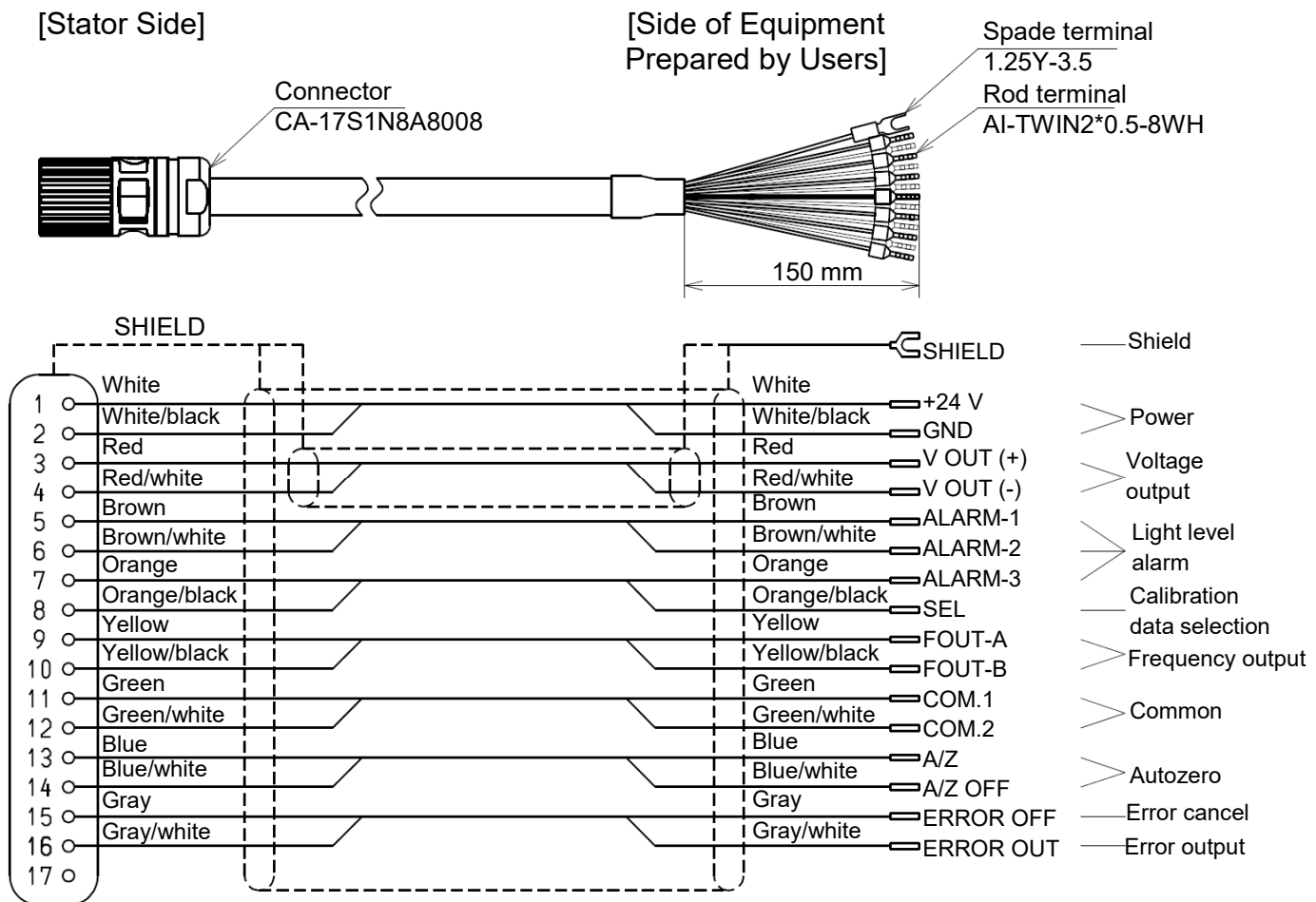

Always use the dedicated cable to connect the equipment to the torque transducer. To avoid increased sensitivity to external noise and loss of accuracy, do not connect an extension cable to the connector board. If the standard cable is too short, contact our sales office or dealer.

4-3. Stator connector pin assignment

Pin layout

Pin No.	Cable color	Signal	Operation
1	White	+24 V	Supply voltage: 24 V
2	White/black	GND	Supply voltage: 0 V
3	Red	V OUT (+)	Torque voltage output: ±10 V
4	Red/white	V OUT (-)	Torque voltage output: 0 V
5	Brown	ALARM-1	ALARM-1 signal (low light level) output terminal. [LOW] is constantly output by the torque transducer when operating normally.
6	Brown/white	ALARM-2	ALARM-2 signal (low light level) output terminal. [LOW] is output by the torque transducer when light levels are low.
7	Orange	ALARM-3	ALARM-3 signal (low light level) output terminal. [LOW] is output by the torque transducer when light levels are too low to maintain performance.
8	Orange/black	SEL	Selects calibration data.
9	Yellow	FOUT-A	Torque frequency output (differential signal)
10	Yellow/black	FOUT-B	Torque frequency output (differential signal)
11	Green	COM.1	Common for external input and output terminals. External input terminal (pin numbers 8, 13, 14, 15) External output terminal (pin numbers 5, 6, 7, 16)
12	Green/white	COM.2	Common for external input and output terminals. External input terminal (pin numbers 8, 13, 14, 15) External output terminal (pin numbers 5, 6, 7, 16)
13	Blue	A/Z	When the torque voltage output is within 10 % of the rating, this activates the autozero function and sets the torque voltage output to 0 V.
14	Blue/white	A/Z OFF	The autozero cancel function operates only when the autozero function is operating, setting the torque voltage output to the current torque.
15	Gray	ERROR OFF	Terminal for canceling error status.
16	Gray/white	ERROR OUT	Error output terminal. [LOW] is output by the torque transducer when an error occurs.
17	-	N.C.	Do not connect.

* Errors refer to the errors described in Section 7-13 Error list and light level status errors.

* COM.1 and COM.2 are common, connected internally.

Connector plug code: CA-17P1N8AHZ00

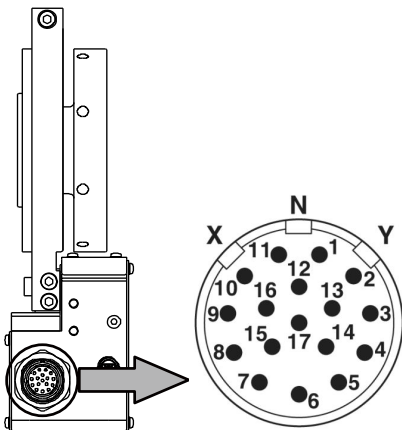

4-4. External control output connections

Low light level alarm

An alarm signal is output externally if normal operation becomes impossible because the rotor and stator are installed in the wrong positions or if the stator sensor is fouled.

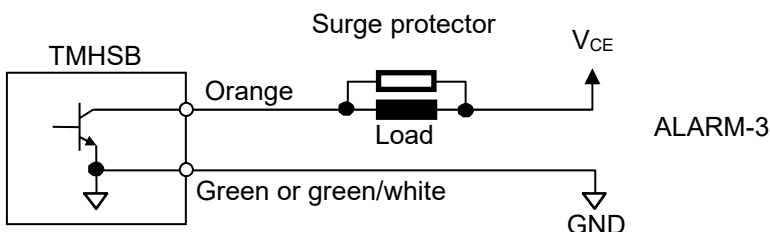
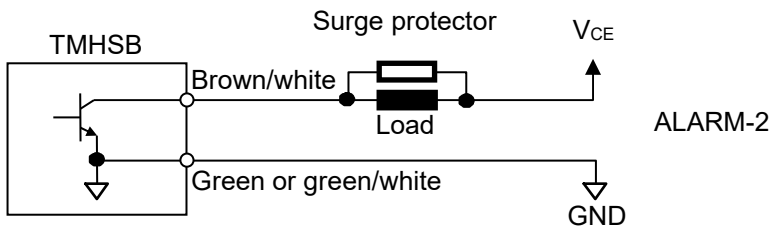
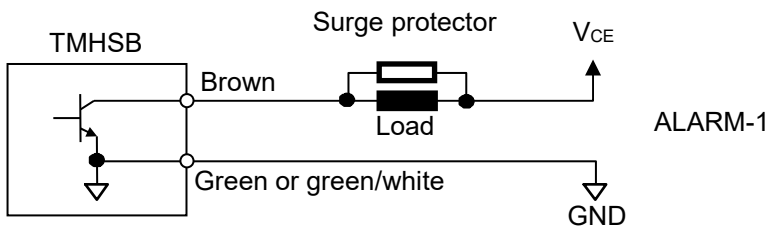

Error

Outputs error signal externally if an error occurs.

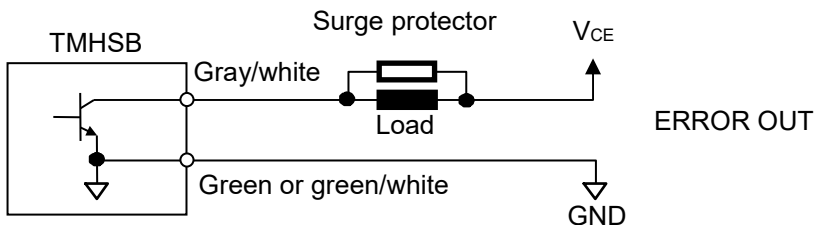

Open collector rating

V_{CE} : 35 V DC I_C : 40 mA DC max.

Cable color	Signal	Operation
Brown	ALARM-1	[Low] when normal
Brown/white	ALARM-2	[Low] at low light levels
Orange	ALARM-3	[Low] when light levels are too low to maintain performance
Gray/white	ERROR OUT	An error has occurred.
Green or green/white	COM.1, COM.2	I/O terminal common wire.

* Errors refer to the errors described in Section 7-13 Error list and light level status errors.



To protect external control output, add a suitable surge protector for the load.

4-5. External control input connections

Functions can be controlled externally via the external control input connectors.

External control input is performed by shorting the corresponding inputs to COM.1 or COM.2 using contacts or an open collector after wiring the connectors.

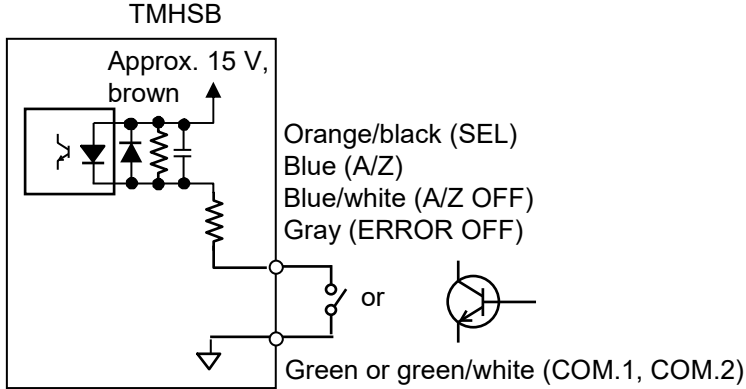

Cable color	Signal	Operation
Orange/black	SEL	Selects calibration data. Two types of calibration data can be selected using external input when parameter F-59 is zero. Calibration data 1 is selected when OFF (open). Calibration data 2 is selected when ON (shorted). When parameter F-59 is 1, calibration data 1 is selected regardless of the external input status. When parameter F-59 is 2, calibration data 2 is selected regardless of the external input status.
Blue	A/Z	When the torque voltage output is within 10% of the rating, this activates the autozero function and sets the torque voltage output to 0 V.
Blue/white	A/Z OFF	The autozero cancel function operates only when the autozero function is operating, setting the torque voltage output to the current torque.
Gray	ERROR OFF	Cancels the error status.
Green or green/white	COM.1, COM.2	I/O terminal common wire.

4-6. Torque voltage output connections

Voltage output for torque is produced by the voltage output connector.

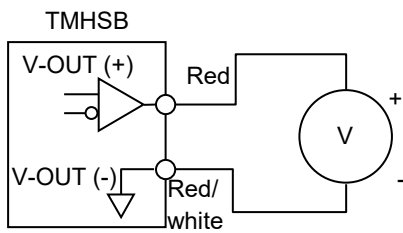

To a digital multimeter, PLC, or similar device

- Load resistance: 2 kΩ or more
- Capacitance load: 0.1 μF or less

4-7. Torque frequency output connections

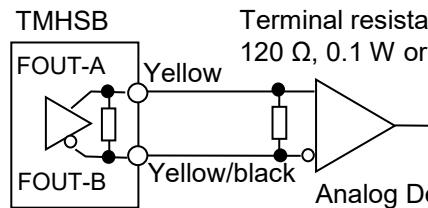

Terminal resistance
120 Ω, 0.1 W or more

Differential line driver:
Frequency counter or other device



For cables longer than 10 m, we recommend using a terminal resistance of 120 Ω between the cables (yellow and yellow/black).

4-8. Power and ground connections

Connect the power supply and ground the unit as shown in the following figure. Use Type D single grounding.

24 V DC, (permissible range: 22 V DC to 26 V DC)

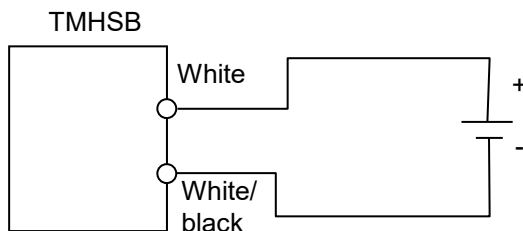

Type D single grounding

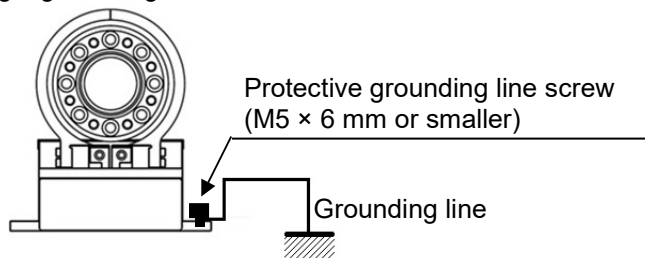

Caution

For power and grounding, connect securely, as shown. Use within the rated power range.



Use Type D single grounding for the equipment. If not, the equipment may be susceptible to noise from other devices, resulting in malfunctions.

5. Testing Operation

5-1. Status display

Check the LED indicator on the side of the stator to confirm normal operation.

Color	Description
Green (lit)	Working normally (sufficient light received)
Green (flashing)	Light received has decreased. → Check the alignment of the rotor and stator. Clean the sensor window.
Red (lit)	Insufficient light received (Error) → Check the alignment of the rotor and stator. Clean the sensor window.
Red (flashing)	The status indicator LED flashes red if any of the errors described in Section 7-13 occur. To cancel this, first clear the problem and perform any of the following actions. <ul style="list-style-type: none"> • Cancel the error using the calibration software. • Cancel using external control input. • Turn the power off and then back on again.



The torque transducer transmits torque signals in the form of light. Thus, optical transmission may be obstructed if the transmitting and receiving components are fouled by oil mist or excessive dust or particles. This may prevent accurate torque signal transmission. Clean the light-transmitting components regularly using a cotton swab or similar based on the status display.

5-2. Checking output

Confirm that the output changes when a torque load is applied.

[Torsion direction and output polarity]

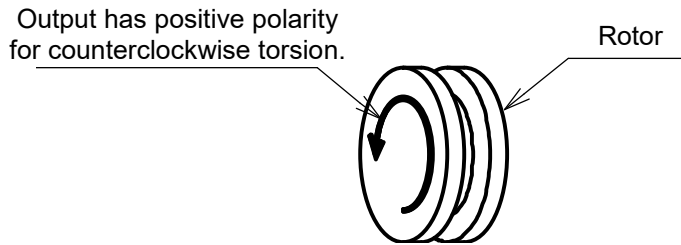

Analog voltage output polarity can be changed by adjusting settings with the calibration software. If the polarity is incorrect, check the settings.

5-3. Running-in operation

Running-in should be performed to ensure that the specified accuracy is achieved.



Wait at least 10 minutes after power startup before performing calibration or measurement.



If you removed and reattached the rotor, perform preloading of positive and negative torque repeatedly to allow the contact to stabilize.

6. Calibration

Calibration refers to the process of adjusting equipment voltage output to match the torque acting on the torque transducer in order to ensure that the electrical signal from the torque transducer is output as an accurate torque value.

For example, this adjustment ensures accurate equipment voltage output of 10.000 V when a torque of 1,000 N·m acts on the torque transducer.

The torque transducer is connected via USB to a personal computer running calibration software.

To use the computer's USB interface, install the dedicated driver on the personal computer.

Use a USB cable no longer than 5 m.

★ For calibration instructions, refer to the calibration software manual.



Warning

Always calibrate the equipment before initial use or if you replace the torque transducer. Failure to calibrate the equipment may result in incorrect measurement, equipment malfunction, and damage to peripherals. Likewise, recalibrate the equipment if it has already been calibrated but gives incorrect results.



- **Recalibrate as needed if used in a different environment.**
- **Before calibration, confirm that the rotor's photoemitters (LEDs) and the stator's sensor window are clean. Dirty photoemitters or a dirty sensor window may prevent correct signal reception, which may in turn prevent correct calibration.**
- **Reattaching the rotor may cause a zero output shift. Restore the zero reading.**

7. Functions

7-1. Analog voltage output

You can convert torque signals (frequencies) input from the torque transducer to analog voltage values for output in a range of ± 10 V.

Use the calibration software to make adjustments.



Caution

- The analog output is set for the two types of calibration data varied by F-59.
- “Torque analog output maximum display value” (F-21) should be applied to each set of calibration data.



- The analog voltage output includes variable output components when the power is first turned on.
- You should wait approximately 10 minutes after turning on the power to ensure stability in use.

7-1-1. Voltage output specifications

Specifications	Details	
Output	-10 V to 10 V DC	
Non-linearity	0.02% F.S.	
Resolution	Approx. 1/12,000 or more	
Over-range	Approx. -12 V DC for [-OL] indication Approx. 12 V DC for [OL] indication	
Output cycles	Approx. 60,000 cycles/s	
Group delay time	Filter settings	Group delay time
	6k Hz	0.27 ms
	1k Hz	0.56 ms
	500 Hz	0.99 ms
	300 Hz	1.7 ms
	100 Hz	5.8 ms
	50 Hz	11 ms
	30 Hz	14 ms
	10 Hz	50 ms
	1 Hz	328 ms

7-1-2. Voltage output fine adjustment

This equipment allows fine adjustment of the voltage output.

Use the calibration software to make adjustments.

7-1-3. Scaling

The maximum and minimum analog outputs for this equipment are set to a torque display of between 0 and 10,000.

The maximum value can be set to a value as desired using the calibration software.

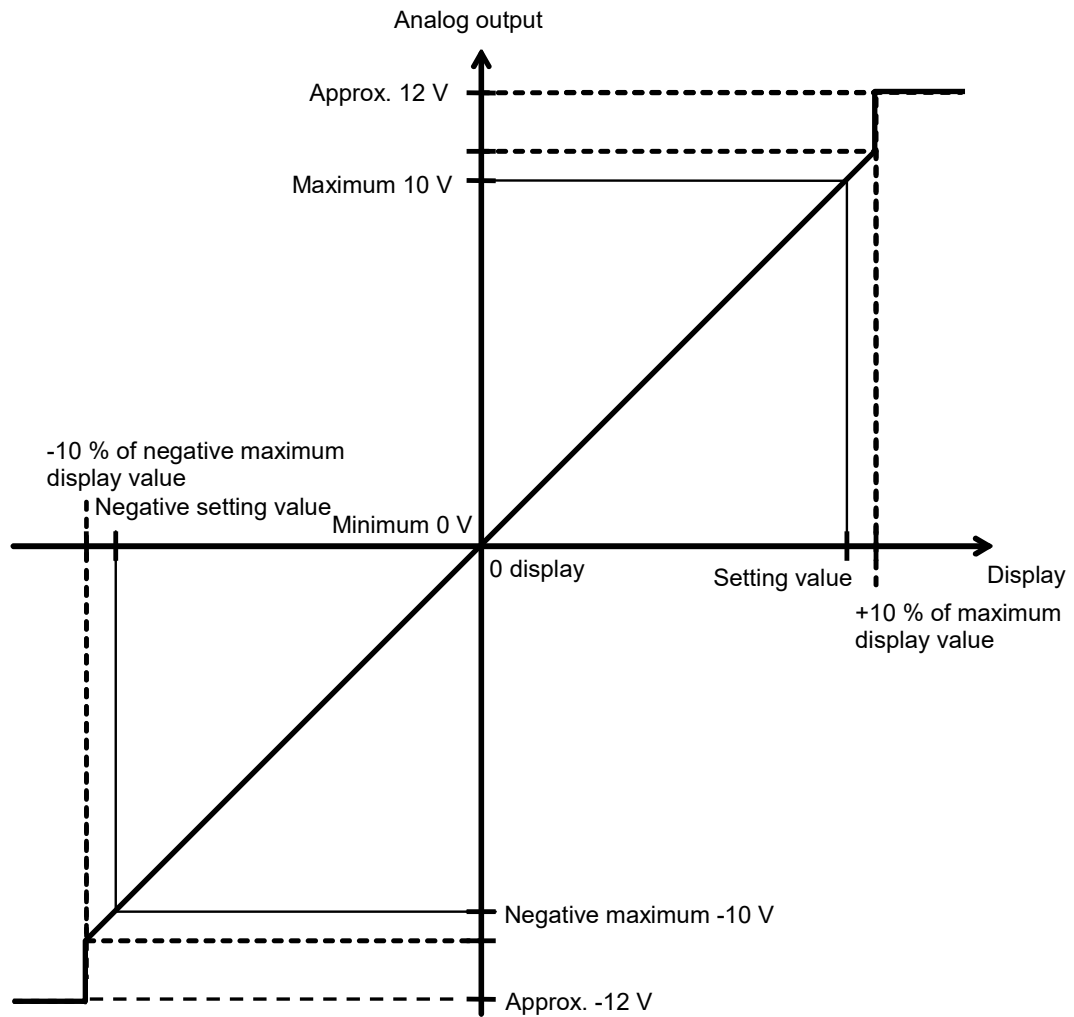

Make sure that the Function Mode F-21 setting does not exceed the maximum display value set in calibration.

Otherwise scaling may not be performed correctly.

7-2. Torque frequency output

You can convert optical torque signals (frequencies) input from the torque transducer to differential voltage frequency signals for output.



No zero or span adjustment functions are available for frequency output. Filters, autozero, symmetry correction, and polarity switching are not available either. Users should make any needed adjustments on their own equipment.

7-2-1. Frequency output specifications

Specifications	Details
Output range	120 kHz to 360 kHz
Output voltage	Differential voltage
Non-linearity	Within 0.02 %R.O.
Resolution	Approx. 0.1 Hz or more
Over-range	108 kHz for [-OL] 372 kHz for [OL]
Output cycles	Approx. 60,000 cycles/s
Delay	Approx. 100 μs

7-3. Filter settings

The equipment includes two filters: a low-pass filter and a stabilizing digital filter that processes the torque signals acquired. Use the calibration software to set up filter functions.



Caution

The low-pass and digital filters affect voltage output. They do not affect frequency output. Inappropriate filter settings may result in incorrect measurements and unforeseen accidents. The voltage output changes the group delay time depending on the setting of the low-pass filter. For details, please refer to 8-4 output signal (voltage) in 8. Specifications.

Low-pass filter for torque

The low-pass filter for torque lets you adjust the responsiveness of the analog output for torque (voltage output).

With this equipment, the analog filter passband for torque can be set to one of nine levels:

1 Hz, 10 Hz, 30 Hz, 50 Hz, 100 Hz, 300 Hz, 500 Hz, 1 kHz, or 6 kHz.

Switching requires a PC and calibration software.

By default, [6 kHz] is selected.

For operating instructions, refer to the calibration software manual.

Frequencies tend to have the following characteristics:

Frequency	1 Hz	100 Hz	6 kHz
Noise resistance	Stable	←————→	Sensitive
Response speed	Slow	←————→	Fast

Digital filter for torque

The digital filter for torque provides stability through moving-average processing of input torque values.

With this equipment, the digital filter for torque can be set in a range of 1 to 4,096 samples. 2ⁿ samples

Where n = 0 to 12

The value set determines the number of moving-average samples for the digital filter for torque.

Setup requires a PC and calibration software.

By default, [1 sample] is set.

★For operating instructions, refer to the calibration software manual.

The number of moving-average samples tends to have the following characteristics:

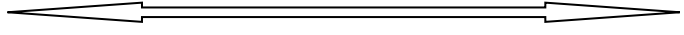
Number of moving-average samples	4,096 samples		1 sample
Noise resistance	Stable		Sensitive
Response speed	Slow		Fast

7-4. Autozero

The equipment has an autozero function for voltage output.

You can restore the zero point (if disturbed by mounting flange removal or attachment, for example) without affecting the span point.

Use the calibration software to enable autozero. It can also be enabled using the [A/Z] external control input signal.

★For operating instructions, refer to the calibration software manual.

The save destination for A/Z data can be selected using the calibration software. The initial value is stored in volatile memory (RAM), so the A/Z data will be lost if the power is turned off. If you wish to retain A/Z data even if the power is turned off, alter the save destination to non-volatile memory (EEPROM).

There are limits to the number of times EEPROM can be overwritten. If A/Z is changed frequently, you should use volatile memory. Overwriting is allowed up to approximately 1 million times.



Autozero is not available for frequency output. Users should make any needed adjustments on their own equipment.

7-5. Symmetry correction

Symmetry can be corrected because the values for clockwise and counterclockwise torque can be registered separately.

Use the calibration software to perform symmetry corrections.

★For operating instructions, refer to the calibration software manual.



Symmetry correction is not available for frequency output. Users should make any needed adjustments on their own equipment.

7-6. Polarity switching function

This is a function for switching the polarity of the torque transducer output.

The default setting is for positive output when torque acts on the transducer in the counterclockwise direction and negative output when torque acts in the clockwise direction. The calibration software can be used to reverse the polarity to negative output for torque acting on the transducer in the counterclockwise direction and positive output for torque acting in the clockwise direction.

Use the calibration software to switch the polarity.

★For operating instructions, refer to the calibration software manual.



Polarity switching is not available for frequency output. Users should make any needed adjustments on their own equipment.

7-7. External control input/output

This equipment can be controlled externally using input signals.

7-7-1. External control input signal

Functions by shorting with COM.1 and COM.2.

Cable color	Signal	Operation
Blue	A/Z (pulse)	When the torque voltage output is within 10% of the rating, this activates the autozero function and sets the torque voltage output to 0 V.
Blue/white	A/Z OFF (pulse)	The autozero cancel function operates only when the autozero function is operating, setting the torque voltage output to the current torque.
Orange/black	SEL (level)	Selects calibration data.
Gray	ERROR OFF	Cancels the error status.
Green, green/white	COM.1, COM.2	I/O terminal common wire.



- The A/Z and A/Z OFF inputs are operated after shorting for at least approximately 100 ms.
- The SEL input is enabled during input after shorting for at least approximately 100 ms.
- COM.1 and COM.2 are shorted internally.

7-7-2. Error output signal

Cable color	Signal	Operation
Brown	ALARM-1	Working normally (sufficient light received)
Brown/white	ALARM-2	Light received has decreased. → Check the alignment of the rotor and stator. Clean the sensor window.
Orange	ALARM-3	Insufficient light received (Error) → Check the alignment of the rotor and stator. Clean the sensor window.
Gray/white	ERROR	[LOW] when an error occurs.
Green, green/white	COM.1, COM.2	I/O terminal common wire.

* Errors refer to the errors described in Section 7-13 Error list and light level status errors.



Optical flange type torque transducers transmit torque signals in the form of light. Thus, optical transmission may be obstructed if the transmitting and receiving components are fouled by oil mist or excessive dust or particles. This may prevent accurate torque signal transmission. Clean the light-transmitting components regularly based on the status display.

7-8. CHECK

The calibration software can be used to output a preset voltage from the analog voltage output.

Setting range: 0 to 20

Output: $(\text{Maximum analog output} - \text{Minimum analog output})/20 \times \text{Preset value}$

For example, if the maximum analog output is 10 V, the minimum analog output is 0 V, and the preset value is 20:

The analog voltage output when [CHECK] is executed in the calibration software will be $(10 \text{ V} - 0 \text{ V})/20 \times 20 = 10 \text{ V}$.

The default setting is [16].

7-9. Calibration data selection

This equipment can save two sets of calibration data.

Setting range: 0 to 2

0: Calibration data depends on external control input.

1: Fixed calibration data 1

2: Fixed calibration data 2

For example, if calibration data 1 is saved as 1kNM and calibration data 2 is saved as 500NM, these can be used as a double range.

The default setting is [0].

If nothing is selected to external control input [SEL], calibration data 1 will be selected.

Shorting external control input [SEL] to [COM.1] or [COM.2] selects calibration data 2.

To select the calibration data regardless of the external control input, use the calibration software.



[Analog voltage output], [Symmetry correction function], [Decimal point display position], and [A/Z value] are saved respectively for calibration data 1 and 2.

7-10. Calibration prohibited

Calibration data can be locked to prevent accidental calibration.

The default setting is for calibration of all data allowed. Note that calibration prohibition applies to the following setting digits.

Setting range: 00 to 11 0: Allowed 1: Prohibited

10⁰ digit: Calibration data 1

10¹ digit: Calibration data 2

Use the calibration software to set up calibration prohibition.

7-11. Error log

This equipment records the time and details of errors that arise.

The error log is saved in non-volatile memory, so it is retained even when the power is turned off.

The clock is backed up using the internal battery. The clock continues to run even when the power is turned off.

The following details can be checked using the calibration software.

- Check time and details of error occurrences
- Delete error log
- Adjust clock

★For operating instructions, refer to the calibration software manual.

7-12. Function list

Use the calibration software to alter settings.

●: Default setting

No.	Item	Settings
F-01	Decimal point display position	●0: No decimal point 1: 1000.0 2: 100.00 3: 10.000 4: 1.0000
F-02	Torque display units	●0: N·m 1: kN·m
F-05	Digital low-pass filter	0: 1 Hz 1: 10 Hz 2: 30 Hz 3: 50 Hz 4: 100 Hz 5: 300 Hz 6: 500 Hz 7: 1 kHz ●8: 6 kHz
F-06	Digital filter	0 to 12: Number of moving average samples = 2^m samples ●0
F-19	Polarity switching	●0: Positive for counterclockwise torque 1: Positive for clockwise torque
F-20	CHECK value	0 to 20 ●16
F-21	Maximum analog output display value	1 to 99999, Units: Digit ●10000
F-26	Data save destination selection	●0: RAM (Save A/Z data to RAM) 1: EEPROM (Save A/Z data to EEPROM)
F-55	Calibration prohibition	0: Calibration allowed 1: Calibration prohibited 10 ⁰ digit: Calibration data 1 10 ¹ digit: Calibration data 2 ●00
F-56	Symmetry correction clear	Executed by entering 1234 (password)
F-59	Calibration data selection	0: External control switching ●1: Fixed calibration data 1 2: Fixed calibration data 2

No.	Item	Settings
F-60	Calibration 1 Minimal scale interval	Reference value
F-61	Calibration 1 Maximum display value	Reference value
F-62	Calibration 1 Actual torque value	Reference value
F-66	Calibration 1 ZERO frequency value	Reference value
F-67	Calibration 1 +SPAN frequency value	Reference value
F-68	Calibration 1 -SPAN frequency value	Reference value
F-70	Calibration 2 Minimal scale interval	Reference value
F-71	Calibration 2 Maximum display value	Reference value
F-72	Calibration 2 Actual torque value	Reference value
F-76	Calibration 2 ZERO frequency value	Reference value
F-77	Calibration 2 +SPAN frequency value	Reference value
F-78	Calibration 2 -SPAN frequency value	Reference value
F-99	Memory clear	Resets function settings to initial values. Executed by entering 1234. (password)

7-13. Error list

Use the calibration software to check the error details.

A/Z	Autozero error. An autozero signal was input outside the autozero range (over 10 % of the maximum display value). Check that no load is acting on the rotor.
EEP	EEPROM write error. Writing to EEPROM failed. Contact us.
IN-1	Missing input error. No torque signal was input. Check the cable connection.
+OL	Torque overload. The input torque value exceeded [+110 % of maximum display value] in Measurement mode. Check that the load acting on the rotor does not exceed the ratings.
-OL	Torque minus overload. The input torque value was less than [-110 % of maximum display value] in Measurement mode. Check that the load acting on the rotor does not exceed the ratings.
+OVF	Torque overflow. The input torque value exceeded the input range in Measurement mode. Check that the load acting on the rotor does not exceed the ratings.
-OVF	Torque minus overflow. The input torque value exceeded the input range in Measurement mode. Check that the load acting on the rotor does not exceed the ratings.
V-Lo	Rotor internal voltage error. The rotor internal voltage was less than 18 V. Check that the antenna bolts are not loose. Check that the rotor and stator antennas are correctly positioned.
B-Lo	The backup battery voltage is low. Contact us.
L-Lo	The received light level is low. Clean the stator sensor window. Check that the stator sensor window is aligned with the rotor LED.

8. Specifications

8-1. Specifications

Model (indicated capacity)	100NM	200NM	300NM	500NM	1KNM	2KNM	3KNM	5KNM	10KNM	
Load characteristics										
Rated capacity (R.C.)	±100 Nm	±200 Nm	±300 Nm	±500 Nm	±1 kNm	±2 kNm	±3 kNm	±5 kNm	±10 kNm	
Safe overload	150 %R.C.									
Ultimate overload	300 %R.C.									
Rated output (R.O.)	Frequency output: 240 kHz ±120 kHz Voltage output: ±10 V									
Measurement accuracy (including nonlinearity, hysteresis, and repeatability)	Frequency output: ±0.02 %R.O. Voltage output: ±0.03 %R.O.									
Temperature characteristics										
Acceptable temperature range	-10 °C to 70 °C									
Operating temperature range	0°C to 60 °C (non-condensing)									
Temp. effect on zero balance	0.02 %R.O./10 °C									
Temp. effect on output	0.03 %LOAD/10 °C									
Rotation characteristics										
Max. rotation speed (rpm)	25,000			22,000		16,000		14,000	12,000	
Noise during rotation	0.5 %R.O.p-p (WB: 6 kHz)									
Other characteristics										
Class of protection	IP54									
Materials	Rotor: Alloy steel									
	Stator: Aluminum alloy									
Fatigue life	10 ⁷ cycles under rated load									
Weight	Rotor (kg)	Approx. 1.0			Approx. 1.2	Approx. 1.6	Approx. 3.5		Approx. 6.0	Approx. 10.2
	Stator (kg)	Approx. 1.5						Approx. 1.7		

8-2. Mechanical characteristics (rotor)

Model (indicated capacity)	100NM	200NM	300NM	500NM	1KNM	2KNM	3KNM	5KNM	10KNM
Response frequency (kHz)	6								
Moment of inertia (kg·cm ²)	13.79	13.80	13.82	19.77	26.86	107.6	107.8	260.3	668.4
Torsional rigidity (kN·m/red)	325.0	371.4	472.7	660.7	909.8	1515	1881	2647	4043
Torsional natural frequency (kHz)	4.757	5.161	5.822	5.701	5.899	3.801	4.258	3.233	2.489
Bending natural frequency (radial direction, kHz)	2.821	2.911	3.073	3.135	3.492	1.763	1.995	1.857	1.368
Bending natural frequency (thrust direction, kHz)	3.458	3.528	3.656	3.715	4.519	2.380	2.590	2.356	1.670
Twist angle (°)	0.018	0.031	0.036	0.043	0.063	0.076	0.091	0.108	0.142
Accurate safe bending load (N)	75	150	225	375	750	800	1000	1650	2750
Accurate safe thrust load (N)	65	130	195	325	650	3750	12000	20000	22000

8-3. Power

Rated power supply	24 V DC \pm 2 V
Current consumed	1 A or less
Rated (nominal) power consumption	24 W or less
Inrush current	9 A (10 ms) at 24 V DC average load conditions

8-4. Output signals (voltage)

Output voltage	\pm 10 V DC	
Resistive load	2 k Ω or more	
Output capacitance load	0.1 μ F or less	
Resolution	Approx. 1/12,000 or more	
Over-range	Approx. \pm 12 VDC	
Output cycles	Approx. 60,000 cycles/s	
Group delay time	Filter settings	Group delay time
	6k Hz	0.27 ms
	1k Hz	0.56 ms
	500 Hz	0.99 ms
	300 Hz	1.7 ms
	100 Hz	5.8 ms
	50 Hz	11 ms
	30 Hz	14 ms
	10 Hz	50 ms
1 Hz	328 ms	

8-5. Output signals (frequency)

Output range	240 \pm 120 kHz
Output voltage	Differential voltage
Resolution	Approx. 0.1 Hz or more
Over-range	Approx. 108 kHz, Approx. 372 kHz
Output cycles	Approx. 60,000 cycles/s
Delay	Approx. 100 μ s

8-6. Adjustment of output voltage

Zero adjustment range	Approx. \pm 10 %R.O.
Moving average	Select 1, 2, 4, 8, 16, 32, 64, 128, 256, 512, 1,024, 2,048, or 4,096 samples (Default: 1 sample)
Low-pass filter	Select 1 Hz, 10 Hz, 30 Hz, 50 Hz, 100 Hz, 300 Hz, 500 Hz, 1 kHz, or 6 kHz (Default: 6 kHz)
Output polarity inversion	Output polarity is inverted relative to the direction of torsion.

8-7. Status display LED

Normal operating status	Green (lit)
Light level low status	Green (flashing)
Insufficient light level status	Red (lit)
Error status	Red (flashing)

8-8. Interfaces

USB (RS-232C)	USB2.0 compliant Output connector: miniUSB connector B type (female) Transmission mode: Half-duplex Sync mode: Asynchronous Baud rate: 115,200 bps Data bit length: 7 bit Parity: Odd Stop bit: 1 bit Terminator: CR+LF
---------------	---



The USB interface is provided for calibration. The USB interface cannot be used to acquire torque values for measurement.

8-9. General specifications

Operating temperature/ humidity range	Temperature	0 °C to 60 °C
	Humidity	Max. 85 %RH (with no condensation)
Acceptable temperature range		-10 °C to 70 °C

8-10. Accessories

Certificate of analysis	1
Instruction manual (Transducer operation manual)	1
Instruction manual (calibration software manual)	1
CD-ROM (calibration software, USB driver)	1
USB cable	1

8-11. Options

Name	Model	Notes
Dedicated cable	CAC-176D-*M	Select 10 m, 20 m, or 30 m. Example: CAC-176D-10M (for 10 m cable)

9. Warranty

9-1. Warranty

The warranty for this equipment is valid for a period of one year from the date of delivery.

Please contact our sales office or dealer from which you purchased the product for repairs or service during the warranty period.

9-2. Repairs

Before requesting repairs, double-check that all connections, settings, and adjustments are correct.

In particular, confirm that torque transducer connections are not disconnected.

If problems remain after these inspections, contact our sales office or dealer from which you purchased the equipment for repairs.

10. Component Service Lives

Components used in the equipment have finite service lives. The exact service lives will vary depending on usage methods and operating conditions, but guideline figures are provided below.

Component	Purpose	Approximate life
EEPROM	Recording calibration data Recording settings Recording A/Z data	Approx. 1 million write cycles to EEPROM (at operating temperature of 25 °C)
Electrolytic capacitor	Removal of power supply noise	Approx. 5 years (at operating temperature of 20 °C)
Battery	Clock backup	Approx. 10 years (at operating temperature of 25 °C)
Infrared LED	Transmitting torque signals	Approx. 10 years (at operating temperature of 25 °C)

11. Maintenance and Inspections

The torque transducer transmits signals optically. This means the signal may not be transmitted or received correctly if the photoemitters (LEDs) or stator sensor window is dirty.

If necessary, clean the photoemitter and sensor window surfaces with ethanol or other solvent.

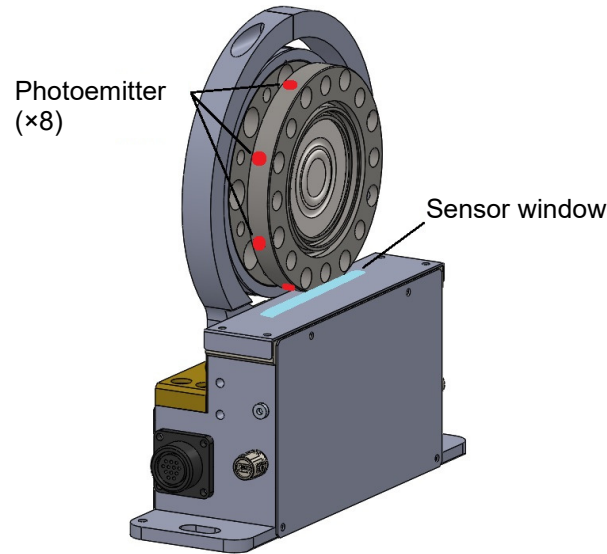

12. Troubleshooting

If readings are unstable or abnormal, confirm that connections with other instruments are correct and that usage precautions are observed, then inspect the torque transducer as described below.

- (1) Confirm that the stator status display LED remains lit in green.
- (2) Confirm that the output changes when you twist the rotor by hand.
- (3) Confirm that the output (zero balance) with no load is not significantly shifted.
- (4) Confirm that the rotor and stator are correctly aligned.
- (5) Confirm that the antenna fixing bolts are not loose.
- (6) Confirm that rotor LEDs and the stator sensor window are free of scratches and dirt.

If the equipment is subjected to overloading or excessive rotating speeds or if the equipment is subjected to overloading in the bending/thrust directions, remove the load and record the difference from the zero output value of the state before subjected to the load.

Be sure to recalibrate and verify that the equipment can be used correctly.

Contact us if you encounter abnormalities or if you have any questions.

The information provided in this manual is subject to change without notice.

●The contents of this manual may subject to change without notice.

HEAD QUARTER: **MinebeaMitsumi Inc.**

4106-73 Miyota, Miyota-machi, Kitasaku gun, Nagano-ken 389-0293 Japan
Tel: +81-267-32-2200 Fax: +81-267-31-1350

Sensing Device Product Sales Management:

1-1-1, Katase, Fujisawa-shi, Kanagawa-ken, 251-8531 Japan
Tel: +81-466-23-2681 Fax: +81-466-22-7191

Sensing Device Business Unit

FUJISAWA PLANT 1-1-1, Katase, Fujisawa-shi, Kanagawa-ken, 251-8531 Japan
Tel: +81-466-22-7151 Fax: +81-466-22-1701

KARUIZAWA PLANT 4106-73 Miyota, Miyota-machi, Kitasaku gun, Nagano-ken 389-0293 Japan
Tel: +81-267-31-1309 Fax: +81-267-31-1353

HOME PAGE ADDRESS <http://www.minebea-mcd.com>