



***TORQUE TRANSDUCER***  
***TMHFB-\*NM***

(for Torque Transducer)

**Instruction Manual**

**MinebeaMitsumi Inc.**

Sensing Device Business Unit

Please read this manual thoroughly before attempting to use the equipment.  
 Be sure to observe the precautions provided in this section.  
 Keep this manual in a safe place where it can be referred to easily when required.

## Pictograms and conventions used in this manual

This manual indicates the prohibited matters, notes and references with the following pictograms.  
 Be sure to read the descriptions provided alongside these pictograms with great care.  
 these pictograms.

	<p><b>CAUTION</b> Caution against factors that may cause injury, accidents, or hazards to personnel.</p> <p>Avoid the actions described here at all times.</p>
---	--

	<p>This indicates operating or procedural precautions or restrictions.        To avoid errors, be sure to read the details provided here.</p>
---	---

### Sec 1: Preface

Thank you for purchasing the MinebeaMitsumi Torque Transducer.  
 First, please make sure that the equipment has not been damaged during shipping and that the model is the one ordered.  
 If there are any problems, contact the MinebeaMitsumi sales office or dealer from which you purchased the product.  
 Verify the individual model specifications by using the catalog or specifications.

### Sec 2: Introduction

This equipment is capable of measuring both static and dynamic torque by using a thin-flange, bearing-free torque transducer combining a torque detector flange calibrated by attaching a strain gauge and an optical transformer that acquires a signal optically, without making contact with the rotor.  
 Features include high precision, high stiffness, improved fatigue resistance, and improved long-term consistency.  
 The stator (antenna unit) has a split configuration to facilitate mounting and detachment.

	<p><b>CAUTION</b></p> <ul style="list-style-type: none"> <li>• Be sure to use the equipment within its rated operating capacity range.</li> <li>• Do not apply voltages to the input terminals exceeding the maximum excitation voltage.</li> <li>• Mount the equipment by hex socket head bolts.            The bolt sizes used are indicated in this manual and in the specifications manual.            Select bolts with a JIS B 1051 strength classification of at least 10.9.</li> <li>• In environments where the bolts are susceptible to coming loose, either make sure the bolts are retightened periodically or include appropriate locking precautions.</li> <li>• If the equipment is mounted on medical equipment or other devices with implications for human life, make sure protective circuits are installed in case the equipment stops functioning.</li> <li>• Contact MinebeaMitsumi before attempting to use in special environments.</li> </ul>
---	--

## Sec 3: Mounting Procedure

## 3-1. Typical mounting configuration

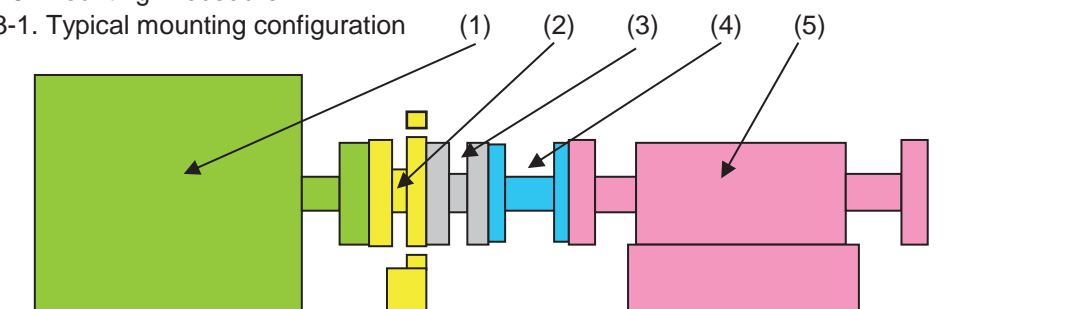

(1)	DY (dynamo)
(2)	Torque transducer TMHFB-*NM
(3)	Coupling (H-flange)
(4)	Flexible coupling
(5)	Intermediate bearing

## 3-2. Mounting flange

It may impede the power supply and cause zero balance shift or drifting when metal objects' is close to the coil which attached to the periphery of the flange on the equipment.

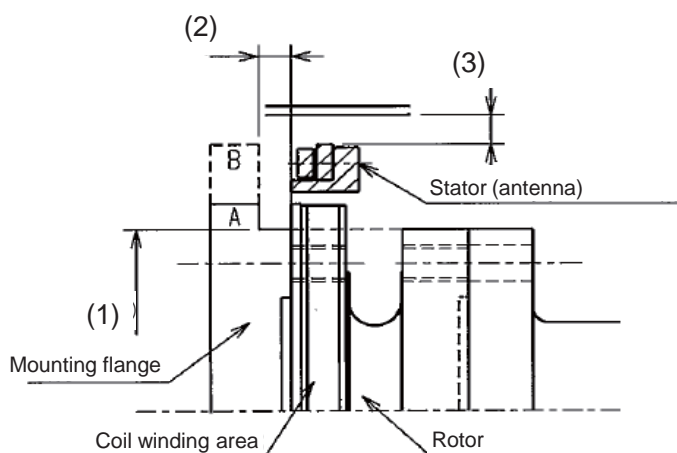

- (1) Mounting unit outer diameter  
Measured to the metal rim of the torque transducer flange.  
Ø123 mm max for TMHFB-100NM to 1KNM  
Ø155 mm max for TMHFB-2KNM, 3KNM  
Ø190 mm max for TMHFB-5KNM, 10KNM
- (2) Distance from torque transducer flange edge face  
At least 8 mm for A type mounting flange configuration (diameter extends to rotor)  
At least 15 mm for B type mounting flange configuration (diameter extends to stator)
- (3) Distance from torque transducer stator periphery (gap with protective cover, etc.)  
At least 10 mm from antenna outer diameter

### 3-3. Mounting procedure

#### (1) Mount the rotor on the rotating shaft.

Before mounting the rotor, wipe off the rust inhibitor on the flange and spigot using ethanol or other solvent. Make sure mounting surfaces are free of debris. Regarding the rotor spigot as a guide and to fix with the specified hex socket head bolts. (See Fig. 1.)

For specific tightening torques, see the separate tightening torque table.

Tighten the eight evenly-spaced bolts by tightening opposite pairs uniformly, first, to 1/4 of the tightening torque; then to 1/2 of the tightening torque; then finally to the specified tightening torque. Please be careful when mounting in case of the damage to the transmission coil (Bakelite bobbin) on the rotor periphery.

After mounting, peel off the green tape protecting the photo emitter.

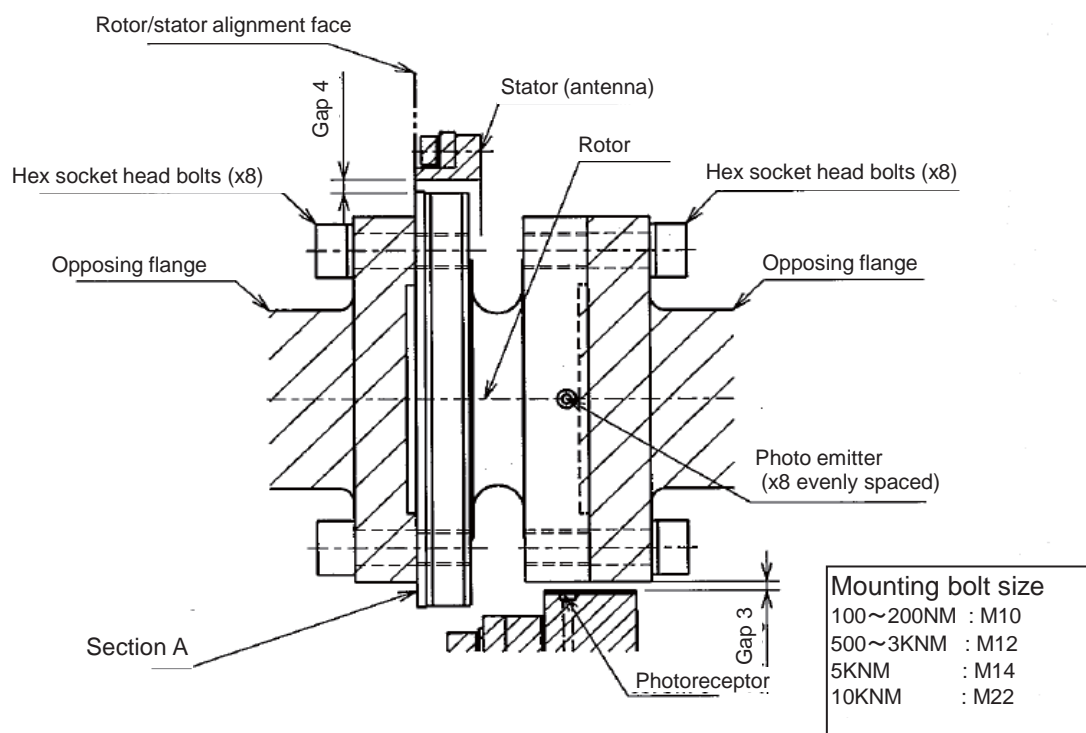

Fig. 1

#### (2) Separate the stator (antenna) and mount aligned with the rotor.

Remove the 6-M6 hex socket head bolts marked as "A" in Fig. 2. Separate the antenna as shown in Fig. 2. Be careful to avoid losing the bolts or flat spring washers attached when detaching.

Insert the rotor inside before reassembling the separated antenna.

Install by sliding the stator on the alignment face in Fig. 1 to ensure the correct shaft orientation.

Align the stator so that it does not make contact with the rotor anywhere along its periphery.

The stipulated gap between the stator and rotor is 4 mm. This can be aligned visually.

Attach the stator using M8 bolts with plain and spring washers.

After securing the stator, fully tighten the bolts on the separated antenna.

Malfunctions may occur if the bolts on the antenna are not properly tightened.

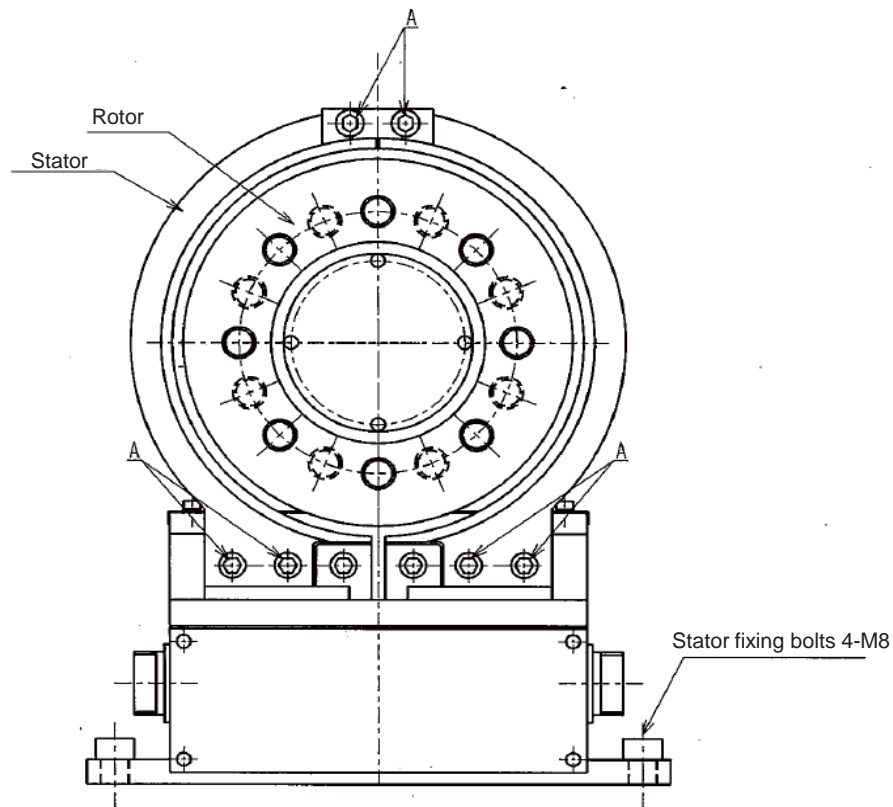

Fig. 2



### 3-4. Mounting precautions

- (1) Select fixing bolts with a JIS B 1051 strength classification of at least 10.9.
- (2) Make sure the thread engagement length of the bolts is not less than the nominal bolt diameter.
- (3) Make sure the stator clamping base is sufficiently stiff and level.
- (4) Be careful to avoid trapping debris and foreign matter inside when mounting.
- (5) Never loosen any bolts other than those specified (6-M6) for separating the antenna.
- (6) Tighten the bolts correctly. Use the tightening torque values given in the table below.

Nominal bolt diameter	Tightening torque (N·m)	
	(N·m)	(kgf·cm)
M6	13.7	140
M8	33.3	340
M10	65.7	670
M12	115	1170
M14	176	1850
M22	686	7000

### Sec 4: Measurement Preparations

#### (1) Wiring

Connect the dedicated cable with the transmitter to be used.

For more information, see the transmitter (CSA-562B) instruction manual.

#### (2) Calibration

Adjust the zero and calibrate the output when operating with no load.

For more information, see the transmitter (CSA-562B) instruction manual.

A positive torque output is generated when the rotor is twisted counterclockwise.  
The output polarity is fixed and cannot be changed.

(3) Test running

Test run the equipment by operating at low speed. Confirm the absence of abnormal output, noise, overheating, or vibration before starting measurement.

Sec 5: Maintenance and Inspections

This equipment transmits signals optically. This means the signal may not be transmitted or received correctly if the photo emitter or photoreceptor is obscured by soot or other contaminants. If necessary, keep the surfaces of the photo emitter and photoreceptor clean by ethanol or other solvent.



Sec 6: Precautions

- (1) This equipment transmits signals optically. While ambient fluorescent lights should present no problems, infrared light from sunlight or incandescent lights may cause malfunctions. Use a protective cover to shield against outside light if the equipment is used in locations where sunlight or incandescent lights are present.
- (2) The antenna stator conveys a current to transmit the input voltage. Do not allow it to come into contact with covers in the vicinity or other metal objects.
- (3) Two signal output connectors are located on the left and right of the stator. These are provided to allow the cable to be connected to either side to suit the installation configuration. Make sure that only one connector is used at any given time. The signal cannot be output from both connectors simultaneously.
- (4) This is a rotating part. Keep a protective cover fitted at all times to prevent material from flying out.
- (5) Vibration may result if the equipment balance is upset after attaching the coupling. Adjust the dynamic balance for the equipment as a whole after combining the torque transducer with the coupling and other devices.
- (6) Impact loads or vibrations will subject the torque transducer to dynamic loads consisting of the static load multiplied by the acceleration. Make sure the value taking into account the acceleration does not exceed the rated capacity of the torque transducer.
- (7) Install safety devices to prevent damage if there is a likelihood of excessive loads acting on the torque transducer.
- (8) Make sure the installation location is sufficiently strong.
- (9) Use the equipment at ambient temperatures within the compensation temperature range.
- (10) Avoid locations subject to sudden temperature fluctuations or direct heat sources.
- (11) Check the protection rating. Make sure the equipment is used under conditions free of condensation.
- (12) Avoid using the equipment in the presence of strong electromagnetic fields. Or it may cause noise interference.
- (13) Take care when handling the transmission coil, photo emitter, and photoreceptor. These parts are especially delicate.
- (14) Avoid bending or pulling the cable outlet with excessive force. Do not grasp the stator by the cable when carrying it.
- (15) If being used in vibration conditions, secure the cable close to the cable outlet to keep it from vibrating.
- (16) In environments where the bolts are susceptible to coming loose, either make sure the bolts are retightened periodically or include appropriate locking precautions.
- (17) If the equipment is mounted on medical equipment or other devices with implications for human life, make sure protective circuits are installed in case the torque transducer stops functioning.
- (18) Do not disassemble the torque transducer.
- (19) Avoid dropping objects to impact on the torque transducer.
- (20) Follow applicable environmental guidelines when disposing of the equipment.

## Sec 7: Troubleshooting

If the equipment is subjected to loads or speeds exceeding permissible tolerances or if the equipment is subjected to excessive loads in the bending and thrust directions, be sure to recalibrate and verify that the equipment can be used correctly.

If the reading is unstable or abnormal, check that the instruments are correctly connected and confirm compliance with all usage precautions before inspecting the torque transducer as follows.

- (1) Use the CHECK switch on the transmitter to confirm that the check value is normal.
- (2) Confirm that the output changes when the rotor is twisted by hand.
- (3) Confirm that the output (zero balance) with no load is not significantly out of adjustment.

Contact MinebeaMitsumi if the above measurements are abnormal.

Contact MinebeaMitsumi if you have any queries about connection procedures or other matters.

Please note that the information provided in this manual is subject to change without notice.