

**NMB**  
MINEBEA CO.,LTD.

## OPERATION MANUAL

(TORQUE TRANSDUCER TMHF-\*NM)

Read this operation manual thoroughly prior to start use of this product.  
Be sure to observe the notes and cautions mentioned in this text of operation manual.  
You will please file this manual in such a way that it is available anytime immediately whenever you want to refer to.

The following are the marks and symbols used in this operation manual. The following are the marks and symbols for the matters which you must not do absolutely or to which you must pay full attention or you must refer to. Be sure to peruse the paragraphs marked with these marks and symbols.

	<b>CAUTION</b>	If not observed , it will cause troubles of injury or damage done to properties or result in endangering a human life. <b>DO NOT DO THE MATTERS MAKED WITH THIS MARK ABSOLUTELY.</b>
---	----------------	---

		This mark shows the limitation or attention which you must pay when operating or working . Be sure to read thoroughly in order to avoid making a mistake in operational procedure.
---	--	--

### 1. Preface

Thank you very much for your purchase of our product MINEBEA TYPE TORQUE TRANSDUCER .  
First of all , you will please check whether or not there is any damage done to the transducer in transit or the model of the unit delivered is as specified in the order sheet .  
If there are any doubtful or unkonwn points , be sure to contact the dealer or our sales office .

Refer to the catalogues or specifications for the specification of related models .

### 2. Outline

This is a torque transducer having the thin type flange /bearingless construction combining an optical transformer of the optical transmission system taking out signals without contacting from a rotary body with the torque detecting flanges that a strain gauge has been stuck and calibrated . Use of this torque transducer makes it possible to make measurement of both static and dynamic torques . This torque transducers are characerized by high accuracy , high rigidity , improvement of fatigue proofness and long term stability etc . The division construction of the stator ( antenna ) has simplified the fitting and removal of it .



## CAUTION

- Be sure to use this unit within the range of rated capacities .
- Be sure not to apply a voltage exceeding the maximum allowable applying voltage .
- Fit this unit , using hexagonal bolts ( holed ) The size of bolts to be used is mentioned in this text of operation manual as well as specification . Selection of bolts shall be made in accordance with STRENGTH DIVISION 10.9 OR HIGHER OF JIS B 1051 .
- In the environment where screws and bolts tend to loosen easily , retighten them periodically or provide a detent thereto .
- In case this unit is fitted to medical treatment apparatuses or machines influencing human life , be sure to provide a protective circuit in preparation for the failure of function of this unit .
- In case this unit is used under special enviromental conditions , be sure to consult with us before use .

## 3. Fitting method

## 3-1 . An example of fitting

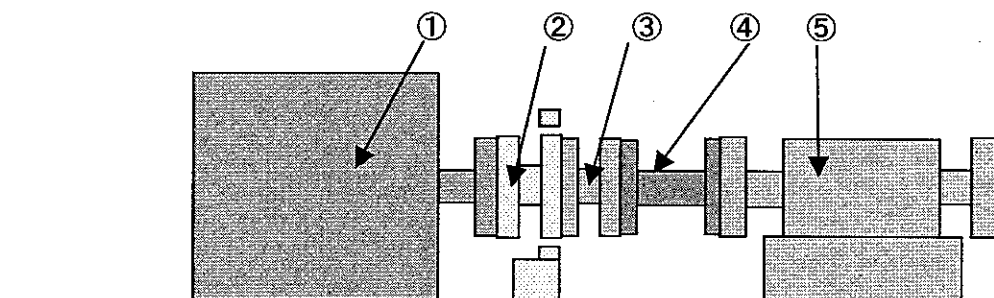

①	DY ( Dynamo )
②	Torque transducer TMHF-*NM
③	Coupli ( H flange )
④	Flexible coupling
⑤	Intermediate bearing

## 3-2. Order of fitting

## (1) Fit a roller on a rotating axis

Before fitting, be sure to wipe off anticorrosive agent coated on the flanges and spigot joint with such solvents as ethanol etc. Prevent dust or foreign matter from sticking on the fitting surface.

With the spigot joint at rotor as a guide, fix it with M12 hexagonal holed bolts.

(Refer to Fig. 1)

Refer to the separate table of tightening torques for the details of tightening torques.

At the time of fitting, full care must be taken to prevent damage from being done to the transmitting coil (bakelite bobbin) located at the outer circumference of the rotor.

After fitting, remove the green tape protecting a luminous element.

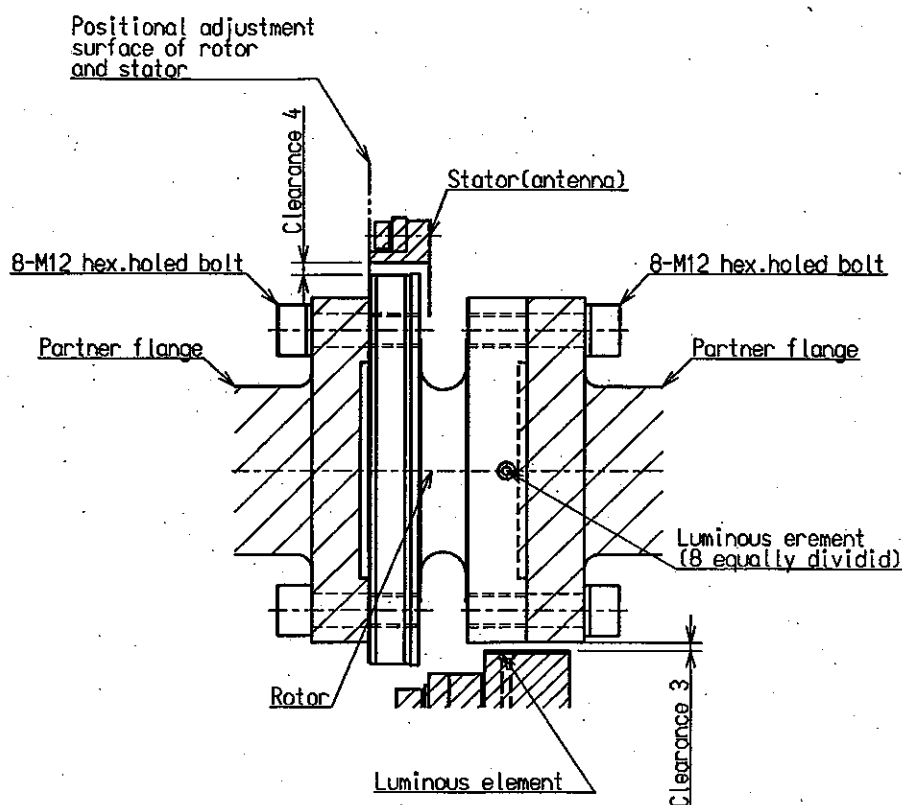

FIG.1

- (2) Dividing the stator ( antenna ), install it by adjusting it to the rotor. Disconnecting 6-M6 hex holed bolts illustrated in Fig. A of fig. 2, divide the antenna. When disconnecting be sure not to lose set bolts, counter-sunk spring washers accidentally. As for the position of axial direction, slide the stator on the positional adjusting surface in Fig. 1 and install it. As for the clearance in a circumference direction, adjust the stator positions to such an extent that rotor and stator do not come in contact with each other. The standard clearance is 4 mm. Visual level positional adjustment may be permitted.
- Install the stator with M8 bolts via flat washers and spring washers. After fixing the stator, tighten the bolts of antenna section which has been divided, reliably and positively.
- If the bolts of antenna are not tightened fully, a trouble of malfunction will be caused.

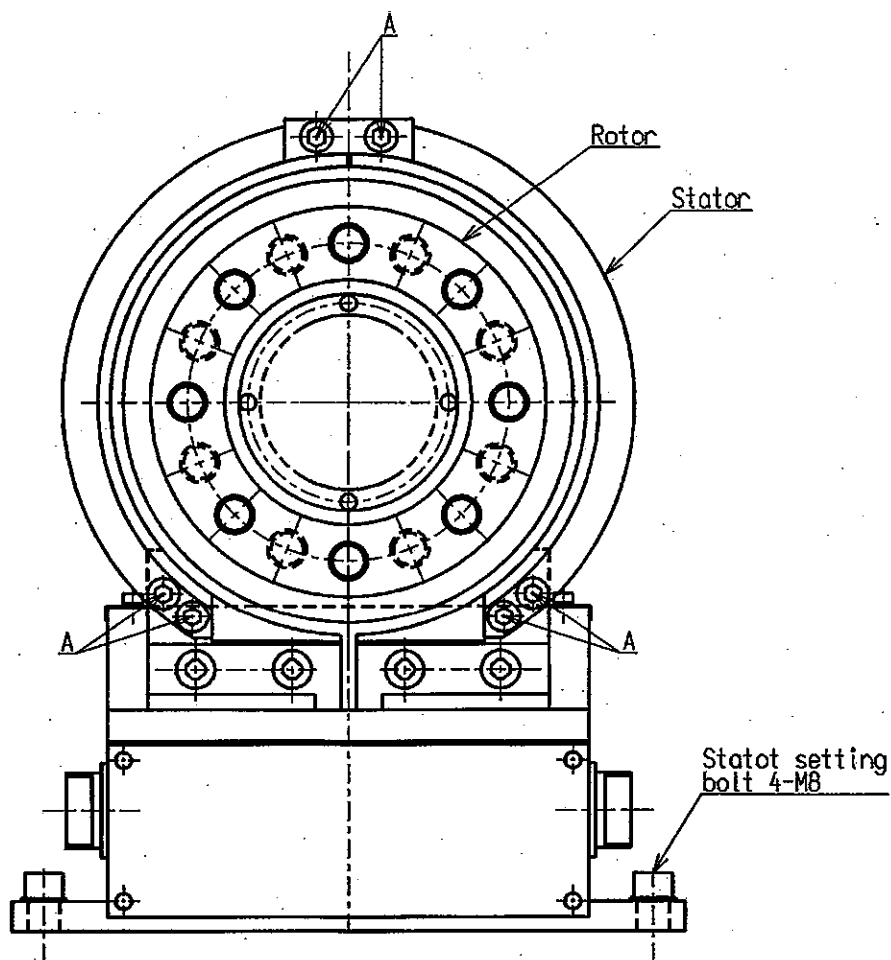

FIG.2

### 3-3. Important points for installation

- (1) Selection of fitting bolts in accordance with the STRENGTH DIVISION 10.9 OR ABOVE OF JIS B 1051 shall be made .
- (2) The fitting length of screws shall be longer than nominal diameters of screws .
- (3) Pedestal of fixing section of stator shall be fully rigid and flat .
- (4) Fit it in such a way that no dust or foreign matter enter it .
- (5) Do not loosen other than the bolts ( 6 -M6 ) specified for division of the antenna absolutely .
- (6) Proper tightening torques are shown in the following table .

NOMINAL DIA . OF BOLT	PROPER TIGHTENING TORQUE	
	(N.m)	(Kgf·cm)
M6	13.7	140
M8	33.3	340
M12	115	1170

#### 4. Preparation for measurement

##### (1) Wiring

Connect the unit with a transmitter to be combined with an attached cable of this unit .  
Refer to the operation manual for the details of transmitter ( CSA-562B ) for the details .

##### (2) Calibration

When no load is applied , adjust zero point and calibrate the output .  
Refer to the operation manual for the details of transmitter ( CSA -562B ) .  
As for torque outputs , when thr rotor is twisted counterclockwise , a plug lutput will be outputted .  
If you want to change the polarity , wire the + and - of the transmitter output cable reversely .

##### (3) Trial operation

Carrying out trial operation at a low speed , check and confirm that there are no abnormal output ,  
sound , temperature , vibration etc . and carry out measuring operations .

#### 5. Maintenance inspection

Signals are taken and received by photo transmission in this transducer . Therefore , if luminous  
and light receiving elements should be stained with black soot etc . , no signals will be taken  
sometimes . In this case , the surface of luminous and light receiving surfaces must be cleaned with  
such solvents as ethanol etc .

#### 6. Cautions for use

- 
- (1) For the reasons of taking and receiving singals by photo transmission , there is no problem at all  
in tha case of fluorescent light etc . But this unit , this unit malfunctions in some cases in the case  
of infrared rays of sun-light and incandescent light . If used exposed to the abovmentioned rays and  
lights , shut off them with a protective cover .
  - (2) An electric current runs for transmission of an input voltage transmission in the antenna section  
of the stator . Therefore , prevent it from coming contact with surrounding metal bodies such  
as cover .
  - (3) There are connectors for taking out of signals at 2 places of both sides .  
The connectors are so arranged that the cable can be taken out in any direction for the reason  
of layout . But , be sure to use only one side . No signal can be taken out at the same time from  
both sides .
  - (4) As it is a rotary body , be sure to fit a protective cover for prevention of flying away .
  - (5) An unbalance cuased by fitting of a coupling results in generation of vibration .  
Therefore , dynamic balance must be adjusted overally sfter combining torque transducer and  
coupling etc .
  - (6) If there should be impact load and vibration , a dynamic load caused by multiplying static load by  
acceleration will act on the torque transducer .  
Therefore , the value calculated by taking accleration into consideration shall not exceed the  
rated capacity of torque transducer .
  - (7) If there is a possibility that an excess load acts on the torque transducer , provide a safety device  
against damage .

- (8) Provide full strength to the installing place .
- (9) Use the torque transducer at the ambient temperature within the temperature compensation range .
- (10) Be sure to avoid rapid change in temperature and direct exposure to heat .
- (11) Checking protection class , be sure to use the torque transducer in the environment free from formation of dew .
- (12) In the enviromental condition where electric and magnetic fields are very intensive , noises will be generated in some times . Be sure to avoid using in such environment .
- (13) Transmission coil , luminous and light receiving elements tend to be damaged easily . Therefore , full care moust be taken when handling them .
- (14) Cable lead-out shall not be pulled forcibly or bent extremely .When carrying , do not suspend the stator section by holding the cable with hand .
- (15) In the vibrating environment , the cord shall be fixed in the vicinity of lead-out of cable and take a measure for prevention of vibration .
- (16) In the environment where screws and bolts tend to loosen , retighten periodically or provide a required detent thereto .
- (17) When fitting the torque transducer to medical treatment apparatuses or other machines influencing a human life , be sure to provide a protective circuit thereto in preparation for failure in function of the torque transducer .
- (18) Do not disassemble the torque transducer .
- (19) Avoid dropping an object on the unit or giving a shock thereto .
- (20) When disused , dispose of it , taking into full consideration environmental condition .

#### 7. Countermeasures to be taken when abnormal

If an overload , RPM bending larger than allowable value or in a thrust direction should be applied , be sure to recalibrate in order to check whether or not it can be used normally .

If indication is unstable or abnormal , check whether or not connection with gauges is correct or reliable or important points for use are observed and then , check the following points of torque transducer .

- (1) With the check switch of transmitter , check whether or not the check values are normal .
- (2) Check whether or not a change takes place when the rotor section is twisted with hand .
- (3) Check whether or not the output at the time of no loading ( zero balance ) is broken markedly .

If there is anything abnormal in the above values , contact with our company .

If you have any doubtful or unknwon point in connection method , be sure to contact us .

The content of this text is subject to change without notice .