



Minebea

MINEBEA Co., Ltd.

INSTRUCTION MANUAL

Digital Indicator for Tie Bar Gage TSD - 591

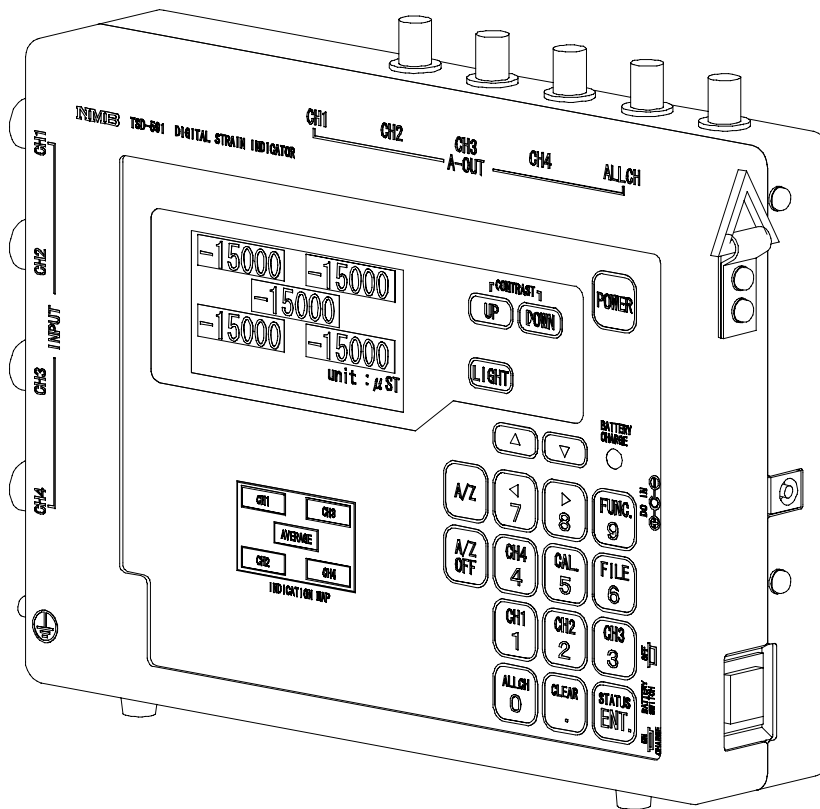

Note : Please read this Instruction Manual carefully before use.
Be sure to follow the items that require attention described in the manual.
Keep the manual at hand so that you can pick it up and read it as soon as
necessity requires.

Forward

Thank you very much for your purchasing MINEBEA's Digital Strain Indicator TSD-591 for Tie Bar Gage.

This manual explains installation procedures and connecting method and also operating method for Digital Strain Indicator TSD-591. Make use of it properly after reading through the manual carefully.

Be sure to deliver the manual to the end user. Moreover, the end user should keep the manual at hand after reading it over.

This manual is intended for technical experts to read.

The contents of the manual which have printed may subject to change without notice for the purpose of improvement.

Marks and arrangement used in this manual

The following marks are added to the explanation on the matters that indicates “Don’t do this.” and “Take care.” and “For reference.”

Be sure to read these items where these marks are added ;



Warning

Warning may cause injury or accident that may harm to the operator.

Don’t do these things described here.



Caution during operation and working.

Be sure to read the item to prevent from malfunction.

Operational mark



Press the switch.

For safe operation

Be sure to read this manual before use.

1. Installation place



Use the instrument where the temperature/humidity specifies within the range as follows:

Environmental temperature : 0 to 50

Environmental humidity : Less than 85 %R.H.(Non condensing.)



When charging a battery, select a location where environmental temperature specifies within the range from 10 to 45 .

(1) Location where installation is not allowed.



Warning

Don't locate the instrument on the places such as follows:

It may cause an unexpected faulty in the instrument.

- Don't locate the instrument in direct and/or high temperature area.
- Don't use the instrument in a high humid area.
- Don't install the instrument where there is high mechanical vibration.
- Don't use the instrument where there is excess of dust and fine particles.
- Don't install the instrument where there is excess of dust and fine particles.
- Don't use the instrument where there are corrosive gas and salt and like that.
- Don't install the instrument where there is rapid change of temperature and humidity.
- Don't install the instrument near the devices that are magnetized or generate an electromagnetic field.
- Avoid the location where chemical reaction may take care such as in a laboratory.
- Since the instrument doesn't feature explosion-proofed constructions, don't use the instrument in the ignitable atmosphere.



The instrument doesn't feature water-proofed nor dust-proofed constructions.

2. Power supply

 Warning As for AC adaptor, be sure to use the attached AC adapter. (ESA1520A : Tamura Corporation) If some AC adaptor is used other than the specified one by MINEBEA, it may cause a damage in the instrument or electric shock to the operator.

 Warning Use the AC adaptor within the specified power supply voltage and power supply frequency. If neglected, it may cause a damage in the instrument or electric shock to the operator.

 Warning Connection should be made after turning off the power. If you work with supplying power, it may cause a electric shock to the operator or may cause a damage in the instrument.

3. Application Notice

 Warning In case of using the instrument, check that the connections are executed properly. If not connected properly, correct measured result will not be obtained, nor it may cause a malfunctions to the instrument, damage to the peripheral equipments or even worse serious accident.

 Warning When change of setting is made carelessly on the instrument during measurement, it may have the possibility of correct measured result will not be obtained, nor it may cause a malfunction of the instrument, the damage to the peripheral equipments or even worse serious accident.

 Warning Don't shock the instrument such as throwing something to it. It may cause the damage to the case or degrading the performance of resisting to environment or operational performance of the instrument.



Warning

Don't push the panel sheet on the instrument with unnecessary strong force nor push it with a sharp edge object such as the tip of the driver or like that.

It may cause damage to the case or panel sheet and even have the possibility of damage to the instrument in resisting to environment or operational performance.





Warning

Don't remove the cover of the case(Replacement of fuse is excluded.) and panel sheet, also and don't take apart the instrument.

It may cause the damage to the case and even have the possibility of damage to the instrument in resisting to environment or operational performance.



At the time of shipment from the factory, the instrument has covered with clear sheet on the monitor display for protective purpose. In case of application, use the instrument after removing the clear sheet first.

For the purpose of safety for the instrument during transportation, battery switch is set as ON, so IN/OUT for power supply with the  key can't be made. When operating the instrument with the AC adaptor or battery, supply power with the  key after setting the battery OFF.

4. Disposal of Ni–Cd battery at the time of wasting the instrument.



Warning

When removing the Ni–Cd battery, turn off the power supply to prevent from electric shock or like that, and disconnect the input terminal and input connector for the instrument.

Moreover, AC adaptor should be removed from the instrument.



Warning

The Ni–Cd battery which has taken out, should be isolated by applying adhesive tape at the (+) terminal on red cable or at the connecting code. Even though used Ni–Cd battery, there may remain electric energy, so it may cause an explosion or a generation of heat if the terminals are not isolated.



The built–in Ni–Cd battery of the instrument is recyclable. When disposing of the instrument, take out the Ni–Cd battery and bring to the recycle cooperative shop for the Ni–Cd battery. Besides, when disposing of the instrument, get rid of it according to the applicable regulation in the district where the battery is applied.

CONTENTS

Forward	I
Marks and arrangement used in this manual	II
For safe operation	III
1. Installation place	III
2. Power supply	IV
3. Application Notice	IV
4. Disposal of Ni–Cd battery at the time of wasting the instrument.	V
Record of revision	VII
1. General	1
1–1. Features	1
2. Each name and function	2
2–1. Front Panel	2
2–2. Side panel	4
2–3. Monitor display	5
3. Connecting method	10
3–1. Note on connections	10
3–2. Connection	10
3–2–1. Connection with tie bar gage	10
3–2–2. Connection of AC adaptor	11
4. Operating procedure	12
4–1. Various mode	12
4–2. Basic operation	12
4–3. Preparation	13
4–3–1. Procedure when strain is displayed	13
4–3–2. Procedure when load by file setting is displayed	13
4–3–3. Procedure when load with actual load calibration is displayed	13
4–3–4. Usage of analog output	14
4–4. Measurement mode	15
4–4–1. Change of display	15
4–4–2. A/Z function	15
4–4–3. A/Z OFF function	16
4–5. File mode	17
4–5–1. About the file mode	17
4–5–2. Change data	17
4–5–3. Default data value	19
4–6. Status mode	20
4–6–1. About the status mode	20
4–6–2. Change data	20
4–6–3. Default data of status mode	22
4–7. Function mode	23
4–7–1. About the function mode	23
4–7–2. Change data	23
4–7–3. Default value of the function data	25
4–8. Another function mode	26
4–8–1. Guide of another function mode	26
4–8–2. Change of data	26
4–8–3. Default value of another function data	28

4-8-4. Various functions of another data	28
4-9. Calibration mode	30
4-9-1. About the calibration mode	30
4-9-2. Selection of calibration kinds	30
4-9-3. Actual load calibration	32
4-9-4. Calibration of analog output 1	34
4-9-5. Calibration of analog output 2	36
4-9-6. Default value of the calibration set(data)	38
4-10. Method of charging up battery.	39
5. Battery	41
6. Trouble shooting	42
6-1. Executing trouble shooting	43
6-2. Error display	48
7. Specifications	49
7-1. Specifications for analog section	49
7-2. Specifications for digital section	49
7-3. File setting function	49
7-4. Analog output	49
7-5. Specification for measurement	49
7-6. General specifications	50
7-7. Accessories	50
7-8. Outline dimensions	50
8. Warranty	51
8-1. Warranty	51
8-2. Repair	51
9. Appendix	52
9-1. Replacement of fuse	52

1. General

The instrument is a digital strain indicator for tie bar gage.

1-1. Features

Main features of TSD-591 are as follows:

(1) Functions as a digital indicator of a tie bar gage output

- The output of four tie bar gages is displayed at the same time.
- Load conversion function
- Load display function with actual load calibration

(2) Liquid crystal display

Adopted easy-to-read back-lit display.

Adopted LED type back-lit, degradation of brightness due to long term application will not be appeared.

(3) Rapid charge

The built-in Ni-Cd battery in the instrument can be charged up within approx. one hour.

2. Each name and function

2-1. Front Panel

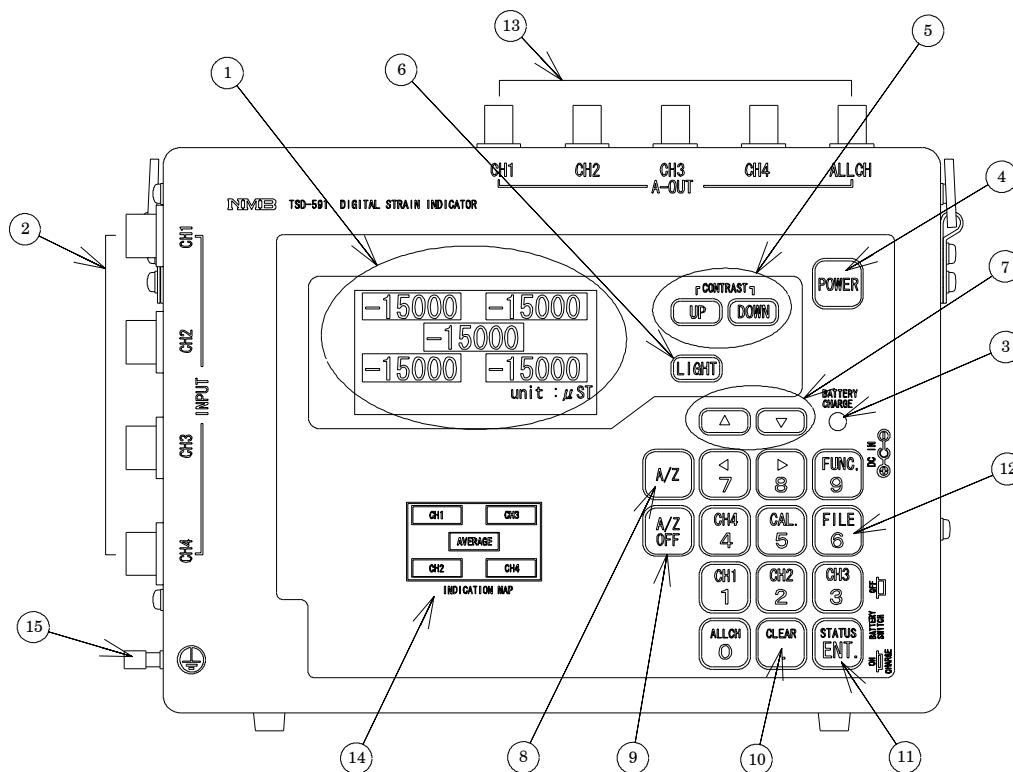

① Display section

A measuring data and a setting condition will be displayed in Measurement mode, and the setting condition will be displayed in Setting mode.

As for various kinds of displays, refer to the paragraph 2-3.

② Input connector

Input connector for tie bar gages.

③ Battery charge lamp

When charging, the condition of charge will be displayed. That is, when charging, it will show red, and when charging is completed, it will become green.

Except for charging, the lamp will not light up.

④ POWER key

Supplying/turning off the power.

⑤ UP key/DOWN key

Performs the adjustment on brightness for display section(Liquid crystal display).

⑥ LIGHT key

Makes ON/OFF for back-lit on the display section.

⑦ ▲ key/▼ key

In Setting mode, they are used for up/down movement of cursor or used for the selection of setting. In the measurement mode, it will change the measurement data.

⑧  key

Executing the A/Z(Automatically to zero).

⑨  key

Executing the A/Z OFF(Cancellation of A/Z)

⑩  key

In the measurement mode, the data of the total (average) is expanding displayed.

In the setting mode, it is used for setting the decimal point “.”, or the operation to clear the setting.

⑪  key

In the setting mode, it is used for the registration of the setting value.

In the measurement mode, it is used for shifting to the status mode.

⑫ 10 keys with function

•  key

In the measurement mode, it will select the display from CH1 ~ CH4 or total (average).

In the setting mode, it will set “0”.

•  key

In the measurement mode, it will display the enlarged data of CH1.

In the setting mode, it will set “1”.

•  key

In the measurement mode, it will display the enlarged data of CH2.

IN the setting mode, it will set “2”.

•  key

In the measurement mode, it will displayed the enlarged data of CH3

In the setting mode, it will set “3”.

•  key

In the measurement mode, it will display the enlarged data of CH4.

In the setting mode, it will set “4”.

•  key

In the measurement mode, it will used for shifting to the calibration mode.

In the setting mode, it will set “5”.

•  key

In the measurement mode, it will used for shifting to the file mode.

In the setting mode, it will set “6”.

-  key

In the setting mode, it will set a left movement of digit or “7”.

-  key

In the setting mode, it will set a right movement of digit or “8”.

-  key

In the measurement mode, it will be used for shifting to the function mode.

In the setting mode, it will set “9”.

⑬ It is the connecting connector for the analog output(0 V to ± 2 V).

⑭ Display position

The display position of each data is shown.

⑮ Earth terminal

It is a terminal for the ground connection.

2-2. Side panel

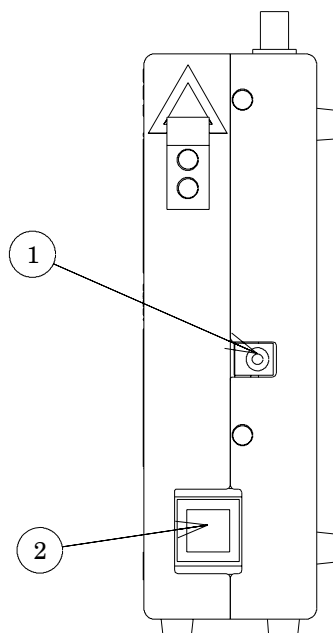

① Jack for AC adapter

Make use of the attached AC adaptor(ESA1520A: Tamura Corporation).

② Battery switch

Used for charging the built-in Ni-Cd battery.

When operation is made through AC adaptor or battery, set the switch to OFF position.

2-3. Monitor display

The instrument prepares the file mode screen, the status mode screen, the function mode screen, and the calibration mode screen where various setting besides the measurement mode screen under the measurement is done.

① The measurement mode screen Example for displaying the strain.

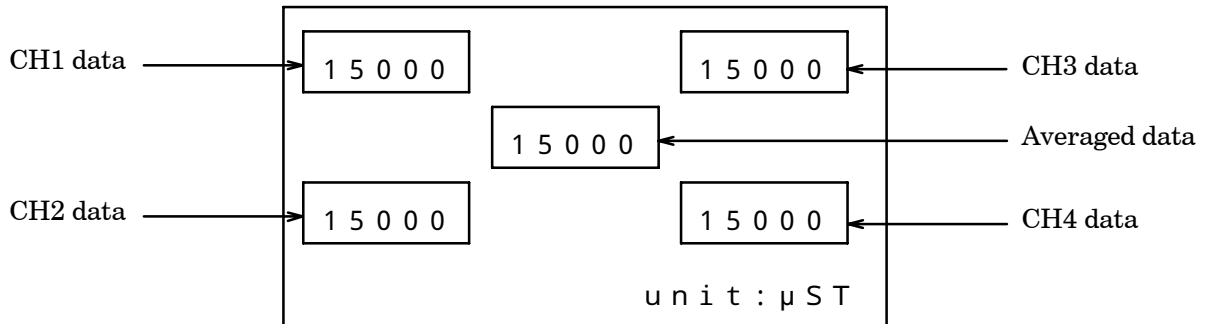

② The measurement mode screen Example for displaying a load by file setting.

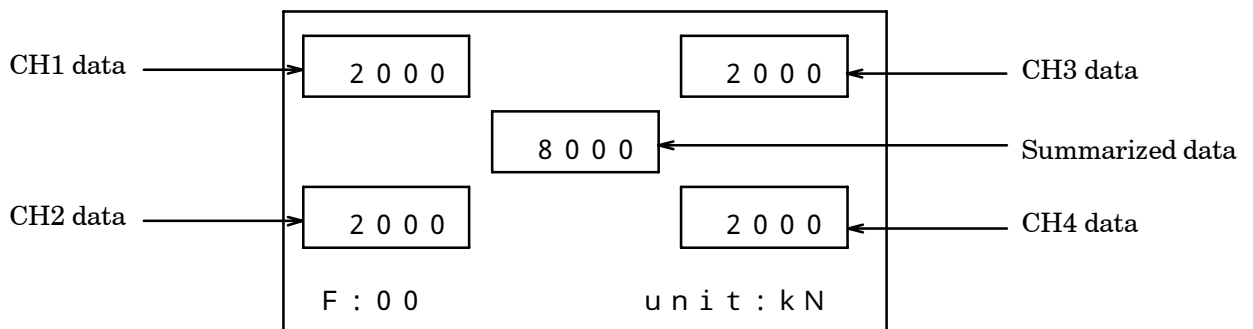

File numbers are displayed in the line below most.

③ The measurement mode screen Example for display a load by actual load calibration.

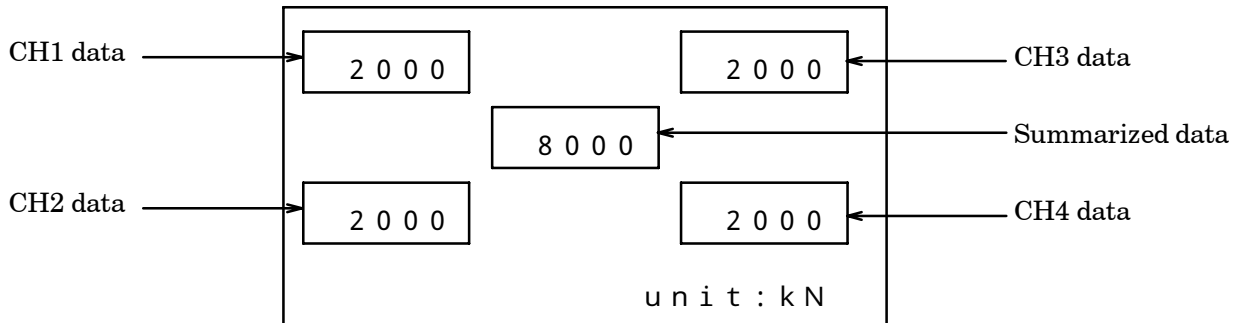

As for the load display by the file setting and the load display with the actual load calibration, the load selected by 01 of the function modes is displayed.

④ The measurement mode screen Example for enlarged strain display.

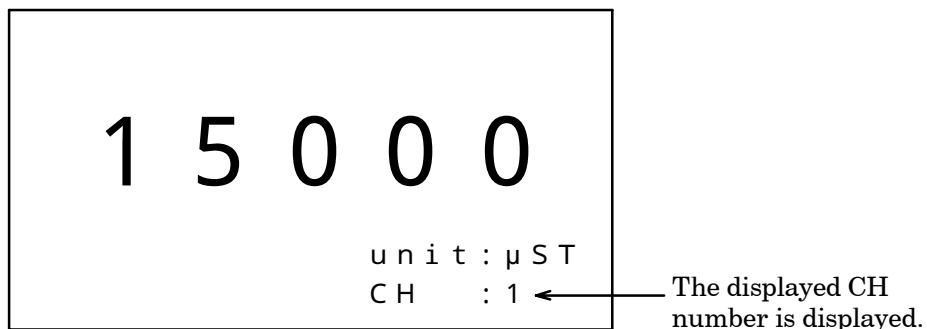

⑤ The measurement mode screen Example for enlarged load display by file setting.

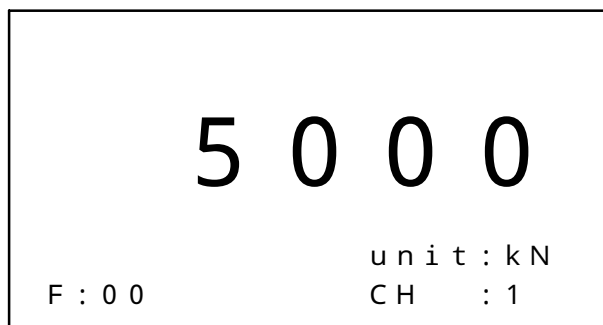

File numbers are displayed in the line below most.

⑥ The measurement mode screen Example for enlarged load display by actual load calibration.



As for the load display by the file setting and the load display with the actual load calibration, the load selected by 01 of the function modes is displayed.

⑦ The measurement mode screen Example for ratio(strain) display.

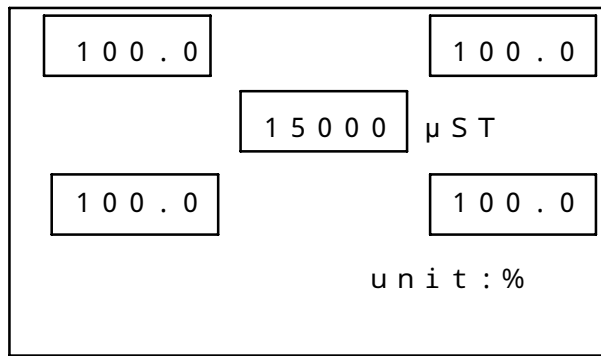

⑧ The measurement mode display Example for ratio display.(load by file setting)

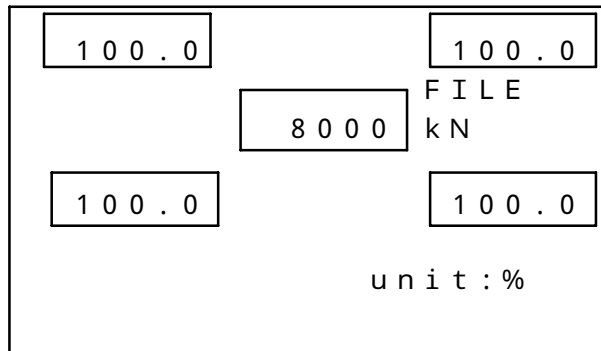

⑨ The measurement mode screen Example for ratio display(load by actual load calibration).

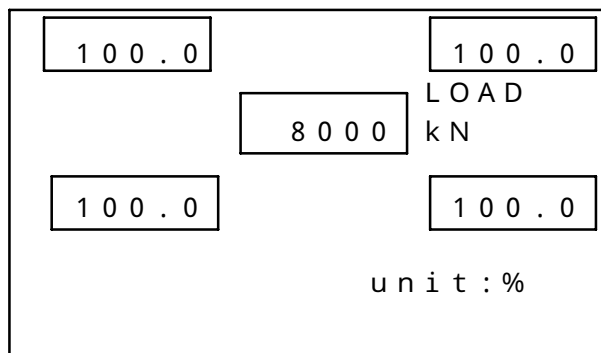

As for the load display by the file setting and the load display with the actual load calibration, the load selected by 01 of the function modes is displayed.

⑩ Display example for file mode

```
          FILE  MODE
FILE      : 01
TI.BAR.  : 100.0mm
YOUNG    : 205.9GPa
UNIT      : kN
POINT    : ###.#
```

⑪ Display example for status mode

```
          STATUS  MODE
CH1 USE   : ON
CH2 USE   : ON
CH3 USE   : ON
CH4 USE   : ON
CH1 G.F.  : 2.00
```

⑫ Display example for function mode

```
          FUNCTION  MODE
00 (%DISP SEL) :  $\mu$ ST
01 (WEIGHT SEL) FILE
02 (A/Z SW) : 0
03 (POW. TIME) : 0min
04 (LIGT TIME) : 10sec
```

⑬ Display example for another function mode

```
          URA  FUNCTION  MODE
00 (DISPLAY) : 16
01 (FIL.TIMES) : 8
02 (MOT.CLK) : 1
03 (MOT.DATA) : 30
04 (MOT.TIMES) : 64
```

⑭ Display example for selecting the calibration mode.

```
      CAL   SELECT
1 : LCAL   MODE OFF
2 : ANALOG MODE 1
3 : ANALOG MODE 2
```

⑮ Display example for actual load calibration

```
      LCAL   MODE
CH   : ALL
UNIT : kN
SCAL : 1
DISP : 150.0
LOAD : 150.0
STEP : ZERO
```

⑯ Display example for calibration of analog output 1

```
      ANALOG   MODE 1
CH   : ALLCH(AVE)
MAX   : 2000  $\mu$ ST
ZERO ADJ : 0  $\mu$ ST
SPAN ADJ : 2000  $\mu$ ST
```

⑰ Display example for calibration of analog output 2

```
      ANALOG   MODE 2
LOAD : SETTING
CH   : ALLCH(SUM)
ZERO ADJ : 0.000 kN
SPAN ADJ : 2.000 kN
```



As for the load display with the actual load calibration, the load selected by 01 of the function modes is displayed.

3. Connecting method

3-1. Note on connections

 **Warning** Keep strict to the following items in case of connection with the instrument. If neglected, it may cause an unexpected failure or a damage to the instrument.

- Be sure to set the power supply OFF when connection is made.

3-2. Connection

3-2-1. Connection with tie bar gage

Connecting method with tie bar gage is as follows:

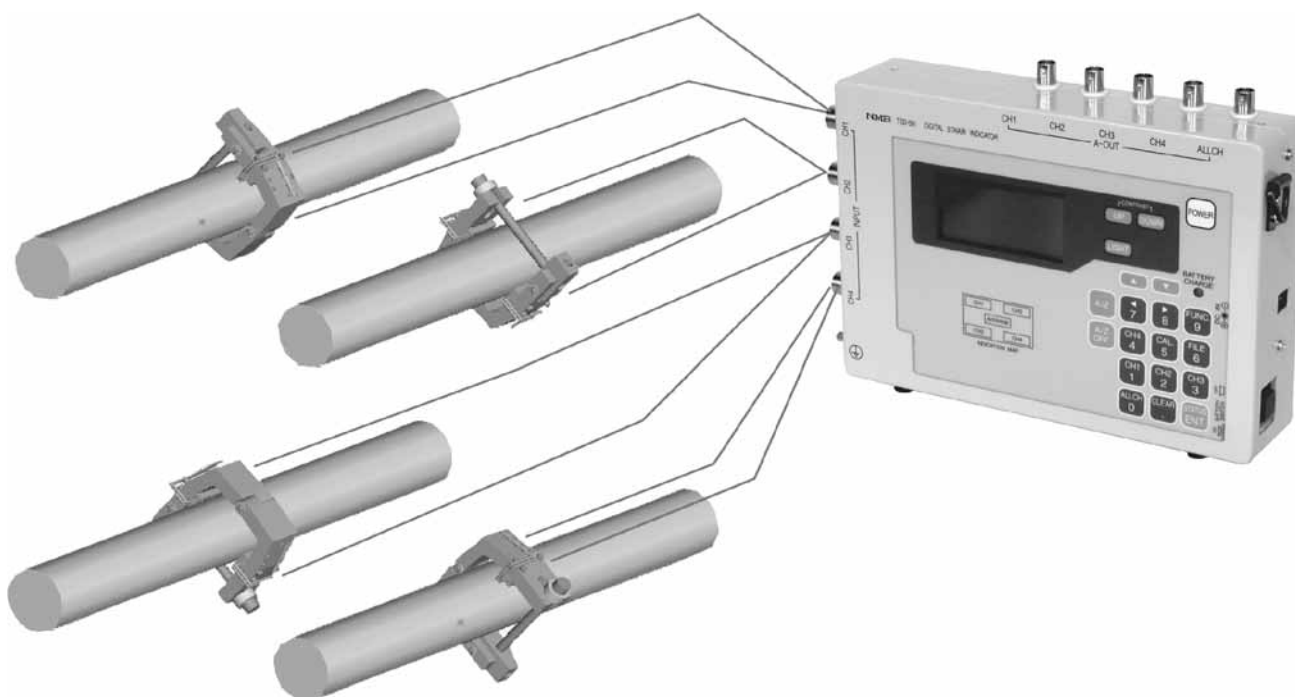

Connect the connectors of tie bar gages with CH1 ~ CH4 of TSD-591.



In the status mode, execute to set in use for connecting channel, and to set in unused for unconnecting channel. If neglected, it may cause an unexpected failure or a damage to the instrument.

3-2-2. Connection of AC adaptor



Warning

As for AC adaptor, be sure to use the attached AC adaptor (ESA1520A : Tamura Corporation).

If other than the AC adaptor specified by Minebea is used, it may cause a damage in the instrument or electric shock to the operator.

Power supply voltage and frequency for AC adaptor should be used within the specified range.

If neglected, it may cause a damage in the instrument or an electric shock to the operator.



The range of power supply voltage for AC adaptor is AC90 V to AC132 V and power supply frequency is 50/60 Hz.

When AC adaptor is connected, AC adaptor has priority over the built-in battery.

When AC adaptor is connected at the time of using battery, power supply will be turned off.

And, when AC adaptor is removed at the time of using AC adaptor, it will change into battery, so power supply will not be turned off.

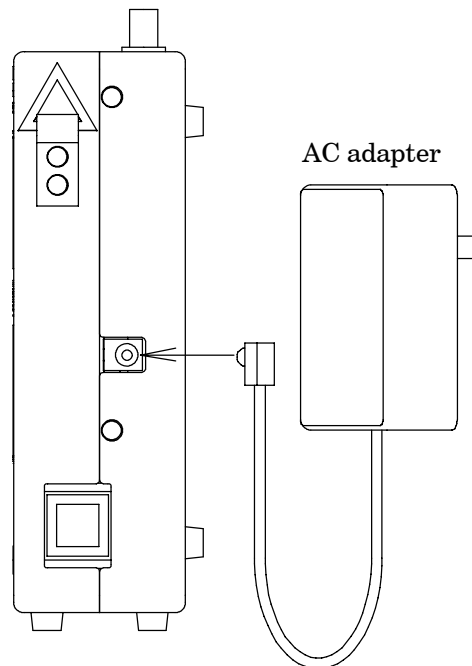

4. Operating procedure

4-1. Various mode

This instrument prepares five(5) kinds of operation mode, such as the measurement mode, file mode, status mode, function mode and calibration mode.

(1) Measurement mode

The strain or load is displayed. Other modes shift from this mode.

(2) File mode

Used for setting the various data for the load conversion when the load display by the file mode is done.

(3) Status mode

Used for setting the used/unused of the connecting tie bar gage, and gage factor.

(4) Function mode

Used for setting the operation in the measuring mode.

(5) Calibration mode

Used for executing the actual load calibration, and analog output calibration.

4-2. Basic operation

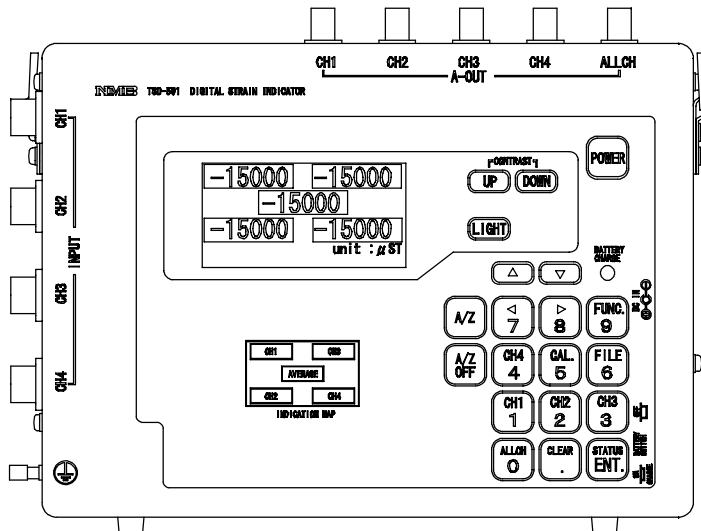



- (1) **POWER** key : Executing the turning on/off of the power supply.
(The power supply is automatically turned off at set time of function 03.)
- (2) **UP** key : The contrast of the liquid crystal display is thinned.
- (3) **DOWN** key : The contrast of the liquid crystal display is condensed.
- (4) **LIGHT** key : Back light of the liquid crystal is turned on and off.
(Back light is automatically turned off at set time of function 04.)



4-3. Preparation

The operation general from setting to the measurement is shown as follows.



4-3-1. Procedure when strain is displayed

- ① This instrument is connected with the tie bar gage
- ② Press the  key, and turn on the power.
- ③ In the status mode(Paragraph 4-6), used/unused of CH and gage factor are set.
- ④ In the measurement mode(Paragraph 4-4), strain display is selected by pressing the  and  key.

4-3-2. Procedure when load by file setting is displayed

- ① This instrument is connected with the tie bar gage.
- ② Press the  key, and turn on the power.
- ③ In the function mode(Paragraph 4-7), function 01 is set in “FILE”.
- ④ In the status mode(Paragraph 4-6), used/unused of CH and gage factor are set.
- ⑤ In the file mode(Paragraph 4-5), tie bar diameter; young’s ratio, unit and decimal point are set.
- ⑥ In the measurement mode(Paragraph 4-4), load display by file setting is selected by pressing the  and  key.

4-3-3. Procedure when load with actual load calibration is displayed

- ① This instrument is connected with the tie bar gage.
- ② Press the  key, and turn on the power.
- ③ In the function mode(Paragraph 4-7), function 01 is set in “load”.
- ④ In the status mode(Paragraph 4-6), used/unused of CH and gage factor are set.
- ⑤ In the calibration mode(Paragraph 4-5), actual load calibration (Paragraph 4-9-3) is executed.
- ⑥ In the measurement mode(Paragraph 4-4), load display by actual load calibration is selected by pressing the  and  key.

4-3-4. Usage of analog output

The voltage output of this unit outputs the result of the calculation with CPU by the voltage by which D/A is converted.

(1) Connection

The voltage output of this unit is output from the connector of CH1-CH4 and ALLCH.

A suitable plug is standard BNC plug. Please use the cable with the shield.

The allocation of the signal is as follows. Please connect the equipment of load resistance 10k or more with this output.

Connector center	+
Connector edge	-

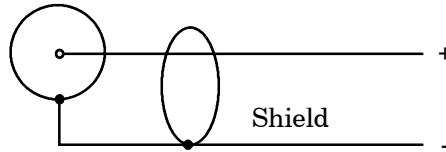

When the strain is displayed, the analog output is done by the value of the calibration in analog output 1 calibration (ANALOG MODE 1).

When the load is displayed, the analog output is done by the value of the calibration in analog output 2 calibrations (ANALOG MODE 2).

4-4. Measurement mode

4-4-1. Change of display

(1) Display item can be switched by pressing the  or  key.

① Strain unit : μ ST

② Ratio unit : %

By the setting of function 00, the target of the ratio display can be selected from either of the strain or the load. When the load is selected, the ratio is displayed by the load set by function 01. When the value which the connected tie rod gage detects is equal, 100.0 is displayed.

③ Load display “The changeover gets the loading mode displayed by setting function 01.”

• Load display by file setting unit : kN or MN

Load value is displayed after converting from the tie bar diameter, young's ratio and strain amount set in the file mode.

• Load display by actual load calibration unit : kN or MN

Load value is displayed after converting from the strain according to the calibration result in the actual load calibration mode.

(2) The displayed CH can be changed by pressing the following key.

①  : Display as for the data of CH1 ~ CH4 and summing value (Strain is average value)

②  : Enlarged display as for the summing value (Strain is average value)

③  : Enlarged display as for the CH1 data

④  : Enlarged display as for the CH2 data

⑤  : Enlarged display as for the CH3 data

⑥  : Enlarged display as for the CH4 data

4-4-2. A/Z function

The operation method is different according to setting the function.

(1) When the function 02 = 0

Automatically zero is executed by pressing the  key. All the display change to zero and をA dotted line frame becomes a solid line frame display.

(2) When the function 02 = 1

Automatically zero is executed by pressing the following key with the  key.

The target CH display changes to zero and a dotted line frame becomes a solid line frame display.

①  : A/Z of CH1-CH4 is done and the display changes to “0”.

②  : A/Z of CH1 is done and the display changes to “0”.

③  : A/Z of CH2 is done and the display changes to “0”.

④  : A/Z of CH3 is done and the display changes to “0”.

⑤  : A/Z of CH3 is done and the display changes to “0”.



If the channel of OVER or - OVER is one, A/Z is not done either.

4-4-3. A/Z OFF function

The operation method is different according to setting of the function.

(1) When the function 02 = 0

A/Z OFF is executed by pressing the  key. The A/Z value of all CH displays is canceled, and the value by which the canceled value is added is displayed. Moreover, a solid line frame becomes a dotted line frame display.

(2) When the function 02 = 1

A/Z OFF is executed by pressing the following key with the  key.

The A/Z value of the target CH display is canceled, and the value by which the canceled value is added is displayed. Moreover, a solid line frame becomes a dotted line frame display.

①  : A/Z OFF of CH1 ~ CH4 is done.

②  : A/Z OFF of CH1 is done.

③  : A/Z OFF of CH2 is done.

④  : A/Z OFF of CH3 is done.

⑤  : A/Z OFF of CH4 is done.

4-5. File mode

4-5-1. About the file mode

It is set to do the load display by the file setting in this mode.



The load is calculated from the strain detected with the tie bar gage by setting the tie bar diameter, young's ratio (tie bar), the decimal point position and the unit.

















If this setting is not correctly done, an accurate load is not displayed.

The file can be registered up to 20 kinds. The file set beforehand can be used by specifying the file number.

4-5-2. Change data

	Procedures	Display
1	<p>Press the  key. "FILE OK ?" is displayed in the second line from the under. At this time, measurement data update is not done. At this time, measurement data update is not done.</p>	<pre> FILE OK? unit:kN CLR.:NO ENT.:YES </pre>
2	<p>Press the  key. It changes into the display of the file mode. Pressing the  key returns to the measurement mode.</p>	<pre> FILE MODE FILE : 01 TI.BAR.: 100.0mm YOUNG : 205.9GPa UNIT : kN POINT : ###.# </pre>

	Procedures	Display
3	<p>The reversed character is moved to the item changed with the  and  key.</p> <p>FILE : File number is set. (Range : 00 ~ 19)</p> <p>TI.BAR. : Tie bar diameter is set. Unit : mm (Range : 10.0 ~ 999.9)</p> <p>YUNG : Young's ratio is set Unit GPa (Range : 0.1 ~ 999.9)</p> <p>UNIT : Unit displayed is set. kN or MN</p> <p>POINT : Decimal point position is selected. (Selected from #####, #.###, ##.## or ###.##)</p> <p>Conversion formula of load by file setting. : Strain [μ ST]</p> <p>A : Sectional area of tie bar (\times Tie bar diameter \times Tie bar diameter) \div 4</p> <p>E : Young's ratio</p> <p>F[kN] = \times A \times E</p>	
4	<p>Press the  key, and fix the changed item. The blinking reversed character moves to the data side, and the number becomes changeable.</p>	<div style="border: 1px solid black; padding: 10px; text-align: center;"> <p>FILE MODE</p> <p>FILE : 01</p> <p>TI.BAR.: 100.0mm</p> <p>YOUNG : 205.9GPa</p> <p>UNIT : kN</p> <p>POINT : ###.#</p> </div>
5	<p>Changing operation</p> <p>(1) For UNIT, change the unit of the display by pressing the  or  key.</p> <p>(2) For POINT, change the decimal point by pressing the  or  key.</p> <p>(3) For FILE, TI.BAR or YUNG, change to the arbitrary numerical value by pressing the  ~  key(numerical value) or  key (decimal point).</p>	
6	<p>Press the  key, and fix the content of the change. Screen returns to the reversing display of the item. Please return to the step 3 when changing again.</p>	
7	<p>Press the  key to quit from the changing procedure. "ENT END ?" is displayed.</p>	

	Procedures	Display
8	<p>Press the  key. The changing procedure is finished.</p> <p>The change is invalidated when  key is pressed, and it returns to the measurement mode (screen).</p> <div style="border: 1px solid black; padding: 5px;">  The load display by the file setting in the measurement mode is done by the content of file number set in this mode at the end. </div>	

4-5-3. Default data value

TI.BAR	100.0 mm
YUNG	205.9 GPa
UNIT	MN
POINT	###.#

4-6. Status mode



4-6-1. About the status mode













In this setting, presence (use) of the connection of the tie bar gage and the gage factor (G.F.) are set.





Please set the CH to ON in connecting the tie bar gage, and to OFF in unconnecting it. When the gage does not set correctly, it will cause the malfunction.

4-6-2. Change data

	Procedures	Display
1	To shift to the status mode, press the  key in the measurement mode. “STATUS OK ? ” is displayed in the second line from the under. At this time, measurement data update is not done.	<pre> STATUS OK? unit:kN CLR.:NO ENT.:YES </pre>
2	Press the  key. It changes into the display of the status mode. Pressing the  key returns to the measurement mode.	<pre> STATUS MODE CH1 USE : ON CH2 USE : ON CH3 USE : ON CH4 USE : ON CH1 G.F. : 2.00 </pre>

	Procedures	Display																		
3	<p>The reversed character is moved to the item changed with the  and  key.</p> <p>CH1 USE : Select whether CH1 is used(ON) or not(OFF)</p> <p>CH2 USE : Select whether CH2 is used(ON) or not(OFF)</p> <p>CH3 USE : Select whether CH3 is used(ON) or not(OFF)</p> <p>CH4 USE : Select whether CH4 is used(ON) or not(OFF)</p> <p>CH1 G.F. : Set the gage factor(G.F.) of CH1. (Range : 1.50 ~ 4.00)</p> <p>CH2 G.F. : Set the gage factor(G.F.) of CH2. (Range : 1.50 ~ 4.00)</p> <p>CH3 G.F. : Set the gage factor(G.F.) of CH3. (Range : 1.50 ~ 4.00)</p> <p>CH4 G.F. : Set the gage factor(G.F.) of CH4. (Range : 1.50 ~ 4.00)</p> <p>Display scrolls.</p> <div style="border: 1px solid black; padding: 5px; margin-top: 10px;">  Please set the CH which does not connect the tie bar gage in no use(OFF). </div>																			
4	<p>Press the  key, and fix the changed item. The blinking reversed character moves to the data side, and the number becomes changeable.</p>	<div style="border: 1px solid black; padding: 10px; text-align: center;"> <table style="width: 100%; border-collapse: collapse;"> <thead> <tr> <th style="width: 15%;"></th> <th style="width: 40%;">STATUS</th> <th style="width: 45%;">MODE</th> </tr> </thead> <tbody> <tr> <td>CH 1 USE :</td> <td></td> <td>ON</td> </tr> <tr> <td>CH 2 USE :</td> <td></td> <td>ON</td> </tr> <tr> <td>CH 3 USE :</td> <td></td> <td>ON</td> </tr> <tr> <td>CH 4 USE :</td> <td></td> <td>ON</td> </tr> <tr> <td>CH 1 G . F . :</td> <td></td> <td>2 . 0 0</td> </tr> </tbody> </table> </div>		STATUS	MODE	CH 1 USE :		ON	CH 2 USE :		ON	CH 3 USE :		ON	CH 4 USE :		ON	CH 1 G . F . :		2 . 0 0
	STATUS	MODE																		
CH 1 USE :		ON																		
CH 2 USE :		ON																		
CH 3 USE :		ON																		
CH 4 USE :		ON																		
CH 1 G . F . :		2 . 0 0																		
5	<p>Changing operation</p> <p>(1) For CH * USE, switch ON/OFF by pressing the  or .</p> <p>(2) For CH * G.F., change to the arbitrary numerical value by pressing the   ~  </p> <p>key (numerical value), or  key(decimal point).</p>																			
6	<p>Press the  key, and fix the content of the change. Screen returns to the reversing display of the item. Please return to the step 3 when changing again.</p>																			
7	<p>Press the  key to quit from the changing operation. "ENT END ?" is displayed.</p>																			

	Procedures	Display
8	Press the  key. The changing procedure is finished. The change is invalidated when  key is pressed, and it returns to the measurement mode(screen).	

4-6-3. Default data of status mode

CH1 USE : ON
 CH2 USE : ON
 CH3 USE : ON
 CH4 USE : ON
 CH1 G.F. : 2.00
 CH2 G.F. : 2.00
 CH3 G.F. : 2.00
 CH4 G.F. : 2.00





When OFF is set in CH * USE, the data display of corresponding CH becomes "N.C."





4-7. Function mode

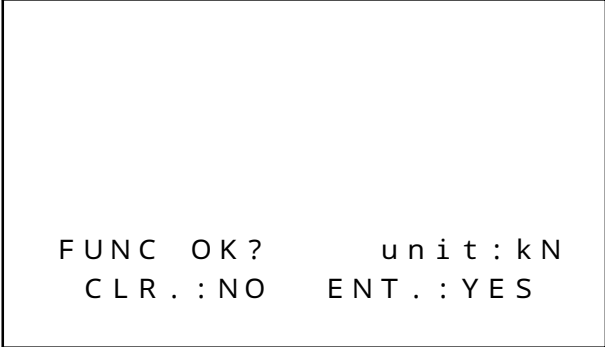

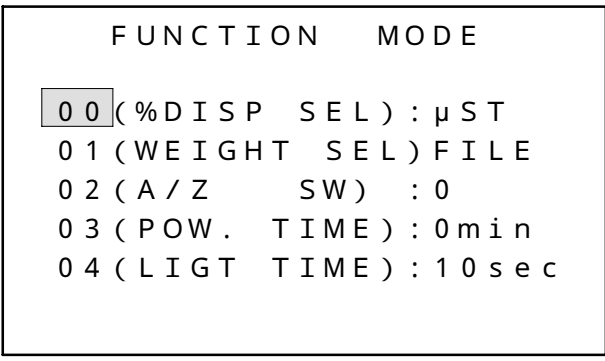

4-7-1. About the function mode

In this mode, a basic setting for the operation of this unit is done.

4-7-2. Change data

	Procedures	Display
1	<p>To shift to the function mode, press the  key in the measurement mode. “FUNC OK ? ” is displayed in the second line from the under. At this time, measurement data update is not done.</p>	 <pre> FUNC OK? unit:kN CLR.:NO ENT.:YES </pre>
2	<p>Press the  key. It changes into the display of the file mode. Pressing the  key returns to the measurement mode.</p>	 <pre> FUNCTION MODE 00(%DISP SEL):µST 01(WEIGHT SEL)FILE 02(A/Z SW) :0 03(POW. TIME):0min 04(LIGT TIME):10sec </pre>

	Procedures	Display												
3	<p>The reversed character is moved to the item changed with the  and  key.</p> <p>00(%DISP SEL) : Selecting the target by which the ratio display is made. μST “Strain” WG. “Load of the file mode” or “Load of actual calibration mode”</p> <p>01(WEIGHT SEL) : Selecting the mode of the load displayed. FILE “Load of file mode” LOAD “Load of the actual load calibration mode”</p> <p>02(A/Z SW) : Selecting the key operation to execute A/Z 0 : Batch, 1 : Specified CH</p> <p>03(POW.TIME) : Setting the automatic power supply OFF time for the power saving. 0 min Turning off by “POWER” switch. 5 min Turning off at 5 min automatically. 10 min Turning off at 10 min automatically. 15 min Turning off at 15 min automatically. 30 min Turning off at 30 min automatically.</p> <p>04(LIGT TIME) : Setting the time to turn off back light. 0 s Turning off by “LIGHT” switch. 10 s Turning off by 10 s automatically. 20 s Turning off by 20 s automatically. 30 s Turning off by 30 s automatically. 60 s Turning off by 60 s automatically.</p> <p>05(MEMO CLR.) : Setting is returned to initial condition. 1 : Return the setting as before. 0 : Not execute.</p> <p>The set value change of the function 00 ~ function 04 and various setting are returned to the initial value.</p>													
4	<p>Press the  key.</p> <p>The blinking reversed character moves to the data side, and the data becomes changeable.</p>	<table border="1" style="width: 100%; text-align: center;"> <thead> <tr> <th>FUNCTION</th> <th>MODE</th> </tr> </thead> <tbody> <tr> <td>00 (%DISP SEL)</td> <td>: μST</td> </tr> <tr> <td>01 (WEIGHT SEL)</td> <td>FILE</td> </tr> <tr> <td>02 (A/Z SW)</td> <td>: 0</td> </tr> <tr> <td>03 (POW. TIME)</td> <td>: 0min</td> </tr> <tr> <td>04 (LIGT TIME)</td> <td>: 10sec</td> </tr> </tbody> </table>	FUNCTION	MODE	00 (%DISP SEL)	: μST	01 (WEIGHT SEL)	FILE	02 (A/Z SW)	: 0	03 (POW. TIME)	: 0min	04 (LIGT TIME)	: 10sec
FUNCTION	MODE													
00 (%DISP SEL)	: μST													
01 (WEIGHT SEL)	FILE													
02 (A/Z SW)	: 0													
03 (POW. TIME)	: 0min													
04 (LIGT TIME)	: 10sec													
5	<p>When you proceed the change operation (1) Change the setting value by pressing the  or  key.</p>													

	Procedures	Display
6	Press the  key, and fix the changed item. The screen returns to the reversed display of the item. When you will change again, return to the step 3.	
7	Press the  key to quit from the changing. “ENT END ? ” is displayed.	
8	Press the  key. The changing procedure is finished. The change is invalidated when  key is pressed, and it returns to the measurement mode(screen).	

4-7-3. Default value of the function data

00(%DISP SEL.)	μ ST
01(WEIGHT SEL)	FILE
02(A/Z SW)	0
03(POW.TIME)	0 min
04(LIGT TIME)	10 s
05(MEMO CLR)	0







4-8. Another function mode

4-8-1. Guide of another function mode

In this mode, the display frequency and the digital filter are set.

4-8-2. Change of data

	Procedures	Display
1	<p>Press the POWER key together with the 7 key, 9 key and CLEAR key in the condition of power OFF to shift to the another function mode. The screen changes into the another function mode.</p>	<pre> URA FUNCTION MODE 00 (DISPLAY) : 16 01 (FIL TIMES) : 8 02 (MOT.CLK) : 1 03 (MOT.DATA) : 30 04 (MOT.TIMES) : 64 </pre>
2	<p>Move the reversed character to the changed item with ▲ key and ▼ key.</p> <p>00(DISPLAY) : Select the display times.</p> <ul style="list-style-type: none"> 1 1 times/s 2 2 times/s 4 4 times/s 8 8 times/s 16 16 times/s <p>01(FIL.TIMES) : Set of digital filter</p> <ul style="list-style-type: none"> 2 Moving average frequency 2 times 4 Moving average frequency 4 times 8 Moving average frequency 8 times 16 Moving average frequency 16 times 32 Moving average frequency 32 times 64 Moving average frequency 64 times 128 Moving average frequency 128 times 256 Moving average frequency 256 times 512 Moving average frequency 512 times <p>02(MOT.CLK) : Time width of stabilized filter</p> <ul style="list-style-type: none"> 0.25 0.25 s 0.5 0.5 s 0.75 0.75 s 1 1 s 1.25 1.25 s 1.5 1.5 s 1.75 1.75 s 2 2 s <p>03(MOT.DATA) : Data width of stabilized filter</p> <ul style="list-style-type: none"> 5 5 counts 10 10 counts 20 20 counts 30 30 counts 50 50 counts 70 70 counts 100 100 counts 150 150 counts 200 200 counts 	

	Procedure	Display
2	04(MOT.TIMES) : Set of stabilized filter 2 Moving average 2 times 4 Moving average 4 times 8 Moving average 8 times 16 Moving average 16 times 32 Moving average 32 times 64 Moving average 64 times 128 Moving average 128 times 256 Moving average 256 times 512 Moving average 512 times 1 024 Moving average 1 024 times 06(STBL.) 07(G.V.) 08(LINER SW) 09(MKS UNIT) Used by MINEBEA (Prohibited to change) 10(CH1 Z) 11(CH1 S) 12(CH2 Z) 13(CH2 S) 14(CH3 Z) 15(CH3 S) 16(CH4 Z) 17(CH4 S) Used by MINEBEA (Only for reference)	
3	Press the  key. The blinking reversed character moves to the data side and it enters the changeable condition.	<div style="border: 1px solid black; padding: 10px;"> <p style="text-align: center;">U R A F U N C T I O N M O D E</p> <p>0 0 (D I S P L A Y) : 1 6</p> <p>0 1 (F I L T I M E S) : 8</p> <p>0 2 (M O T . C L K) : 1</p> <p>0 3 (M O T . D A T A) : 3 0</p> <p>0 4 (M O T . T I M E S) : 6 4</p> </div>
4	When the change operation is made; Press the  key and the  key to change the set value.	
5	By pressing the  key, the change is fixed. It returns to the reversing display of the item. In addition, return to procedure 2 when changing.	
6	Press the  key to end the change. “ENT. : END ? ” is displayed.	
7	Press the  key. Change procedure is finished. The change is invalidated by pressing the  key and it returns to the measurement mode (screen).	

4-8-3. Default value of another function data

00(DISPLAY)	16
01(FIL.TIMES)	8
02(MOT.CLK)	1
03(MOT.DATA)	30
04(MOT.TIMES)	64
06(STBL.)	5 (Prohibited to change)
07(G.V.)	1 (Prohibited to change)
08(LINER SW)	1 (Prohibited to change)
09(MKS UNIT)	0 (Prohibited to change)

4-8-4. Various functions of another data

(1) Display times

The display frequency is selected by setting back function 00.

The display frequency is selectable from "1 times/s", "2 times/s", "4 times/s", "8 times/s", and "16 times/s".

Default has selected "16 times/s".

(2) Digital filter

The function of digital filter is to stabilize the A/D converted data by the moving average processing.

The moving average frequency is selected by setting of another function 01.

The moving average time is selectable from "2 times", "4 times", "8 times", "16 times" and "32 times". The default has selected "8 times".

The tendency to the characteristic by moving average is shown in the table below.

Moving average times	little		Much
Anti noise	Sharp	↔	Stable
Response speed	Quick	↔	Slow

(3) Stabilized filter

The function of stabilizing filter is to make the digital filter strong when the change width of strain display is constant and

① Time width of stabilized filter

The time width of the stabilization filter is set by another function 02.

It is selectable from "0.25 s", "0.5 s", "0.75 s", "1 s", "1.25 s", "1.5 s", "1.75 s" and "2 s".

The default has selected "1 s".

② Data width of stabilized filter

The data width of stabilization filter is set by another function 03.

It is selectable from "5 counts", "10 counts", "20 counts", "30 counts", "50 counts", "70 counts", "100 counts", "150 counts" and "200 counts"

The default has selected "30 counts".

③ Set of stabilized filter

The moving average times is set by another function 04.

It is selectable from “2 times”, “4 times”, “8 times”, “16 times”, “32 times”, “64 times”, “128 times”, “256 times” and “512 times”

The default has selected “64 times”.

The stabilization filter set in another function 03 becomes effective when the changing width of load display is within the value set by another function 03, and that condition is continued for the time set in another function 02.

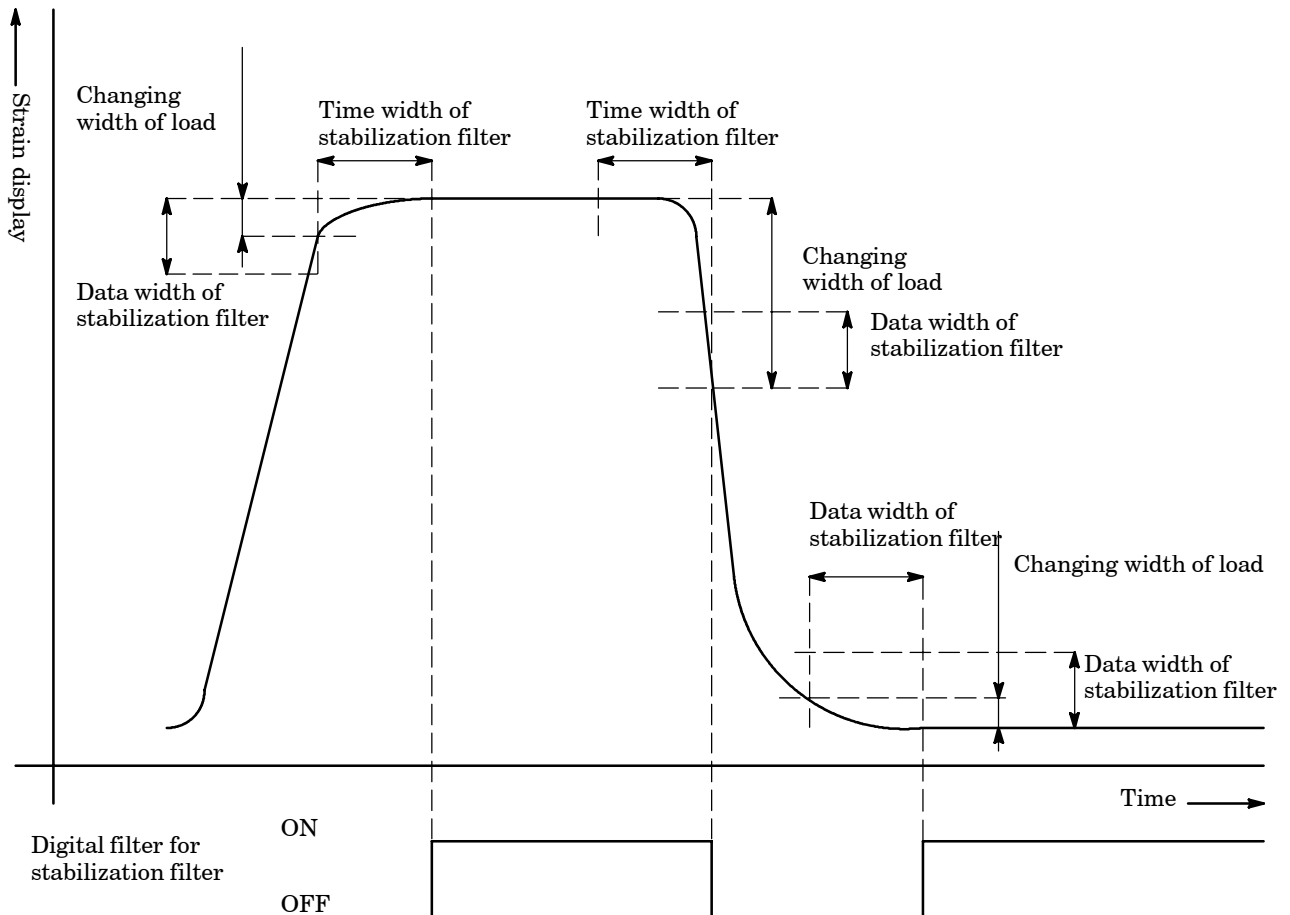

The moving average process executes the “Moving average of stabilization filter” after the “Moving average of digital filter”.

4-9. Calibration mode

4-9-1. About the calibration mode

This instrument prepares the following calibration.

① Actual load calibration

It is a mode by which load “0” and load “Theoretical value” is decided with the actual load condition.

In the load displayed by function 01, it is a effective function only to select “LOAD”.



② Analog output 1



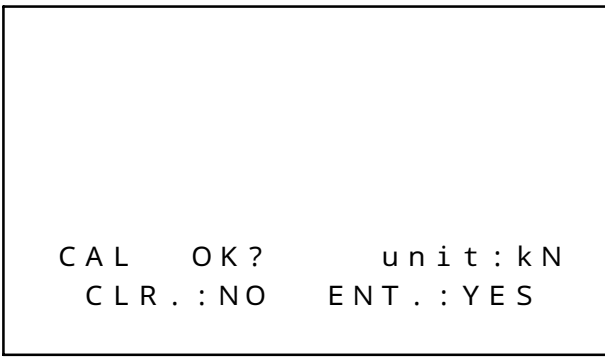

The analog output at the strain display is adjusted.

③ Analog output 2

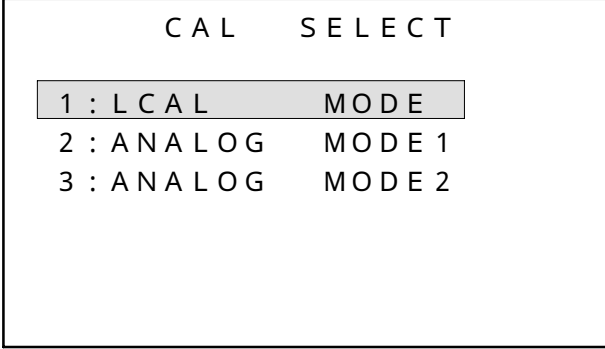











The analog output at the load display is adjusted.



















4-9-2. Selection of calibration kinds

	Procedures	Display
1	To shift to the calibration mode, press the  key in the measurement mode. “CAL OK ?” is displayed in the second line from the under. At this time, measurement data update is not executed.	 <pre> CAL OK? unit:kN CLR.:NO ENT.:YES </pre>
2	Press the  key. Display changes into the calibration mode The display returns to the measurement mode when  key is pressed.	 <pre> CAL SELECT 1 : LCAL MODE 2 : ANALOG MODE 1 3 : ANALOG MODE 2 </pre>















	Procedures	Display
3	<p>The reversed character is moved to the item changed with the  and  key</p> <p>1 : LCAL MODE Execute the actual load calibration. When "FILE" is set by function 01, it is not selectable. The character of "OFF" is displayed.</p> <p>2 : ANALOG MODE1 The analog output at the strain display is adjusted.</p> <p>3 : ANALOG MODE2 The analog output at the load display is adjusted.</p>	<pre> CAL SELECT 1 : LCAL MODE OFF 2 : ANALOG MODE 1 3 : ANALOG MODE 2 </pre>
4	<p>Press the  key. "MODE SELECT ?" is displayed in the second line from the under.</p>	<pre> CAL SELECT 1 : LCAL MODE 2 : ANALOG MODE 1 3 : ANALOG MODE 2 MODE SELECT ? CLR. : NO ENT. YES </pre>
5	<p>Press the  key, and fix the content of the change. The display changes into the selected calibration screen. It returns to the measurement mode by pressing the  key.</p>	





4-9-3. Actual load calibration

	Procedures	Display
1	<p>The reversed character is moved to the item calibrated with the  and  key.</p> <p>(1) CH : Selection of calibration input (2) UNIT : Selection of displayed unit (3) SCAL : Displayed minimum unit (4) DISP : The maximum indicated value (theoretical value) (range ~ 9999 However, 999.9 becomes the maximum with the decimal point.) (5) LOAD : This input of time phase of calibration (range ~ 9999 However, 999.9 becomes the maximum with the decimal point.) (6) STEP : Calibration operation</p>	<pre> L C A L M O D E CH : ALL UNIT : kN SCAL : 1 DISP : 150.0 LOAD : 150.0 STEP : ZERO </pre>
2	<p>Press the  key, and fix the content of the change.</p>	<pre> L C A L M O D E CH : ALL UNIT : kN SCAL : 1 DISP : 150.0 LOAD : 150.0 STEP : ZERO </pre>
3	<p>Select the calibrated CH by the  or  key. CH1 ~ CH4 or ALL(ALL is calibrating all CH at the same time.)</p> <p>When the channel which does not set use in the status mode is selected, "ER-C" is displayed for two seconds.</p>	
4	<p>Press the  key, and fix the content of the change. Then, return to step 1.</p>	
5	<p>In the step 1 and 2, the item is fixed to UNIT, and the unit displayed is selected by the  or  key. kN or MN</p>	
6	<p>Press the  key, and fix the content of the change. Then, return to step 1.</p>	
7	<p>In the step 1 and 2, the item is fixed to SCAL, and the minimum unit displayed is selected by the  or  key. Please select from 1, 2 and 5</p>	
8	<p>Press the  key, and fix the contents of the change. Then returns to the step 1.</p>	



	Procedures	Display
9	In the step 1 and 2, the item is fixed to DISP, and the rated load is input by  ~  (numerical value) keys and  (decimal point) key.	
10	Press the  key, and fix the content of the change. Then, return to the step 1.	
11	In the step 1 and 2, the item is fixed to LOAD, and the load which can be actually added is set by the  ~  (numerical value) keys and  (decimal point) key.	
12	Press the  key, and fix the content of the change. When the LOAD value is larger than the DISP value, "ENT." does not become effective. Return to the step 1.	
13	In the step 1 and 2, the item is fixed to STEP, and set the load(force) to 0 condition.	
14	Press the  key. "ZERO" display blinking start blinking stop Interrupts the calibrating operation when the  key is pressed, and return to "STEP".	
15	Press the  key, and fix the zero point. The display changes to the "SPAN".	
16	In step 11, make the condition to add the load (force) set in LOAD value.	
17	Press the  key. "SPAN" display blinking start blinking stop When the input is not within the regulated range, "ER-S" is displayed for two seconds. Interrupts the calibrating operation when the  key is pressed, and return to "STEP".	
18	Press the  key, and fix the span point. The display changes to "END" blinking.	
19	Press the  key, and fix the content of the change. The reversed character moves to "STEP".	
20	Press the  key to finish the change. "ENT. END ?" is displayed.	
21	press the  key. The change procedure is finished. The change is invalidated when  key is pressed, and it returns to the measurement mode.	

















4-9-4. Calibration of analog output 1

	Procedures	Display
1	<p>The reversed character is moved to the item changed with the  and  key.</p> <p>(1) CH : Selection calibration input (2) MAX : Setting of strain indication value at the output of 2.000 V (3) ZERO ADJ : Output adjustment at the display of “0” (4) SPAN ADJ : Output adjustment at the display of “MAX”.</p>	<div style="border: 1px solid black; padding: 5px;"> <p style="text-align: center;">ANALOG MODE 1</p> <p>CH : ALLCH(AVE)</p> <p>MAX : 2000 μST</p> <p>ZERO ADJ : 0 μST</p> <p>SPAN ADJ : 2000 μST</p> </div>
2	<p>Press the  key, and fix the changing item.</p>	
3	<p>Select the calibrating CH by the  or  key. CH1 ~ CH4 or ALLCH(AVE) When the channel which does not set use in the status mode is selected, “ER-C” is displayed for two seconds.</p>	<div style="border: 1px solid black; padding: 5px;"> <p style="text-align: center;">ANALOG MODE 1</p> <p>CH : ALLCH(AVE)</p> <p>MAX : 2000 μST</p> <p>ZERO ADJ : 0 μST</p> <p>SPAN ADJ : 2000 μST</p> </div>
4	<p>Press the  key, and fix the content of change. Then, return to step 1.</p>	
5	<p>In the step 1 and 2, the item is fixed to MAX, and the strain display value at the output of 2.000 V is set by the  ~  (numerical value) keys and  (decimal point) key.</p>	
6	<p>Press the  key, and fix the content of change. Then, return to the step 1.</p>	
7	<p>In the step 1 and 2, the item is fixed to ZERO ADJ, and the output value of the target CH at zero is adjusted by  and  key. CH1 ~ CH4 or ALLCH(AVE) Adjust the output to 0.000 V</p> <p> key : Increase the output  key : Decrease the output</p>	
8	<p>Press the  key, and fix the output at zero. Then, return to step 1.</p>	

	Procedures	Display
9	<p>In the step 1 and 2, the item is fixed to SPAN ADJ, and the output value of target CH at span is adjusted by ▲ and ▼ key. CH1 ~ CH4 or ALLCH(AVE) Adjust the output to 2.000 V.</p> <p>▲ key : Increase the output ▼ key : Decrease the output</p>	
10	<p>Press the  key, and fix the output at span.</p>	
11	<p>Press the  key. “ENT. END ? ” is displayed.</p>	
12	<p>Press the  key. The changing procedure is closed.</p> <p>The change is invalidated when  key is pressed, and it returns to the measurement mode.</p>	

4-9-5. Calibration of analog output 2

	Procedures	Display
1	<p>The reversed character is moved to the item calibrated with the ▲ and ▼ key.</p> <p>(1) LOAD : Selection of load used in the calibration.</p> <p>(2) CH : Selection of calibrating input</p> <p>(3) ZERO ADJ : Output adjustment at the display of “0” load</p> <p>(4) SPAN ADJ : Output adjustment at the display of “Theoretical value” load.</p>	<pre> ANALOG MODE 2 LOAD : REAL. CH : ALLCH(SUM) ZERO ADJ : 0 kN SPAN ADJ : 2000 kN </pre>
2	<p>Press the 8 key, and fix the changing item.</p>	
3	<p>Select the calibration value by the ▲ and ▼ key. SETTING or REAL.</p> <p>SETTING : Display the setting value in the actual load calibration.</p> <p>REAL. : Display the actual load in the adjustment</p>	<pre> ANALOG MODE 2 LOAD : REAL. CH : ALLCH(SUM) ZERO ADJ : 0 kN SPAN ADJ : 2000 kN </pre>
4	<p>Press the  key, and fix the content of the change. Then, return to the step 1.</p>	
5	<p>In the step 1 and 2, the item is fixed to CH, and the calibrated CH is selected by ▲ and ▼ key.</p> <p>CH1 ~ CH4 or ALLCH(SUM) (SUM si summing value)</p> <p>When the channel which does not set use in the status mode is selected, “ER-C” is displayed for two seconds.</p>	
6	<p>Press the  key, and fix the content of change. Then, return to step 1.</p>	

	Procedures	Display
7	<p>In the step 1 and 2, the item is fixed to ZERO ADJ, and the output value of the target CH at zero is adjusted by  and  key.</p> <p>When SETTING is selected, “0” is displayed by the blinking reversed character. When REAL. is selected, a present load value is displayed by the reversed character.</p> <p>Adjusts the output to 0.000 Vす。</p> <p> key : Increase the output</p> <p> key : Decrease the output</p>	
8	<p>Press the  key, and fix the output at zero. Then, return to step 1.</p>	
9	<p>In the step 1 and 2, the item is fixed to SPAN ADJ, and the output value of the target CH at span is adjusted by the  and  key.</p> <p>Adjust the output to 2.000 V.</p> <p>When REAL. is selected, a present load value is displayed by the reversed character. When the load display is LOAD mode, “DISP setting value at the actual load calibration” when SETTING is selected is displayed by blinking reversed character.</p> <p>By the following key operation, scaling of 2.000 V output is possible by the optional load.</p> <p>Input the load to output “2.000 V” by  ~  (numerical value) key or  (decimal point) key.</p> <p> key : Increase the output</p> <p> key : Decrease the output</p>	
10	<p>Press the  key, and fix the output at span.</p>	
11	<p>Press the  key.</p> <p>“ENT. END ? ” is displayed.</p>	
12	<p>Press the  key.</p> <p>The changing procedure is closed.</p> <p>The change is invalidated when  key is pressed, and it returns to the measurement mode.</p>	

4-9-6. Default value of the calibration set(data)

(1) Actual load calibration

CH : ALL
UNIT : kN
SCAL : 1
DISP : 1 500
LOAD : 1 500

(2) Calibration of analog output 1

CH : ALLCH(AVE)
MAX : 2 000 μ ST
ZERO ADJ : 0 μ ST
SPAN ADJ : 2 000 μ ST

(3) Calibration of analog output 2

LOAD : SETTING
CH : ALLCH(SUM)
ZERO ADJ : 0 kN
SPAN ADJ : 1 500 kN

4-10. Method of charging up battery.







Warning



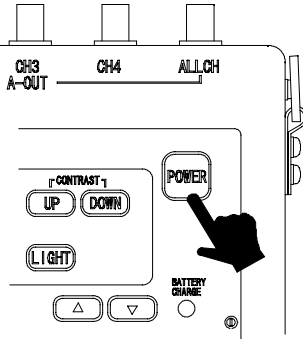

Don't charge when the battery is cold.(0 or less)

If you neglect it, liquid leakage from battery, or degradation of performance and life may be occurred.

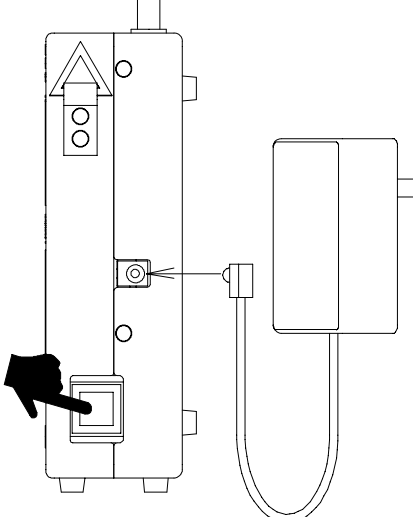

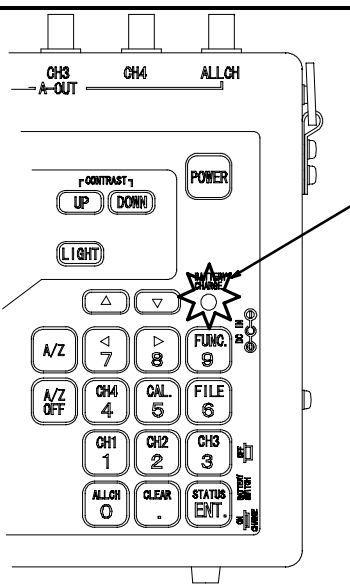
Charging should be applied within the environmental temperature from 10 to 45 .

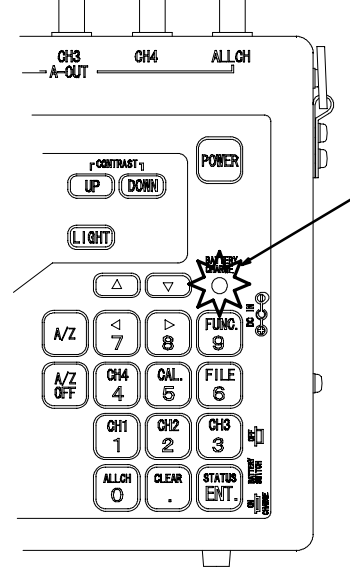
Procedures		
1	<p>When power is supplied, turn off the power supply with the  switch.↓ ↓.</p> <div style="border: 1px solid black; padding: 5px; margin-top: 10px;">  The instrument can't operate while charging up the battery.(Floating charge) </div>	
2	<p>Don't connect anything with input connector and output connector. Connect the attached AC adaptor.</p> <div style="border: 1px solid black; padding: 5px; margin-top: 10px;">  Power supply voltage for AC adaptor is within the range of AC90 V to AC132 V, and power supply frequency is 50/60 Hz. </div> <p>Set the battery switch to the ON position.</p>	

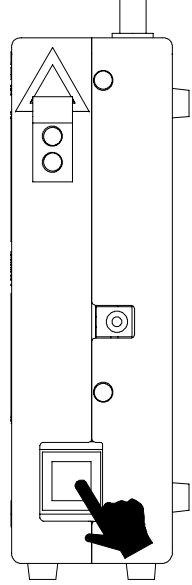
Procedures		
3	<p>Battery lamp will become red and charging will be started. Charge-up time is approx. 1 hour.</p>	 <p>Red lamp (in charging battery.)</p>
4	<p>When charging is completed, the battery lamp will become green.</p> <div style="border: 1px solid black; padding: 5px; margin-bottom: 10px;"> <p> Warning : It takes more than 1 hour and 15 min to finish the charge-up time for the battery. If it takes more than 1 hour and 15 min and still the battery is not filled, suspend the charge compulsively. (Set the Battery switch to OFF position). If you keep charging the battery, it may cause the liquid leakage from battery.</p> </div> <div style="border: 1px solid black; padding: 5px;"> <p> Though the charge-up time for battery is approx. 1(one) hour, there may have the case that charging will be completed within one(1) hour due to charging condition of battery.</p> </div>	 <p>Green lamp (Complete in charging the battery.)</p>
5	<p>When the Battery lamp becomes green, set OFF the Battery switch. The instrument can be operated through the battery.</p> <div style="border: 1px solid black; padding: 5px; margin-top: 10px;"> <p> Except for charging, set the Battery switch to the OFF position.</p> </div>	

5. Battery

The instrument prepares built-in Ni-Cd battery.

The battery can't be used unless charging. As for charging method for battery, refer to the paragraph 4-10. During the operation of the instrument through battery, the battery empty mark on the monitor will reverse on and off when battery voltage decreases.

Moreover, if the instrument is operated in spite of on/off of the battery empty mark, power supply for the instrument will cut off automatically for the purpose of protecting battery.

In due course, when the battery empty mark starts on/off, be sure to recharge the battery.

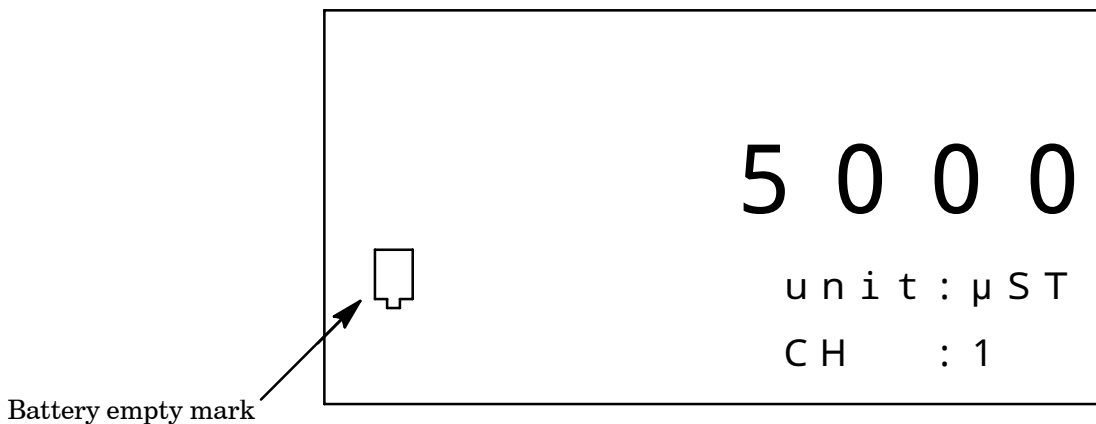

The use time of the this instrument when the battery is used is different according to connected numbers of tie bar gages and environmental temperature, etc. In the undermentioned table, the battery is average continuous duty time from the condition of the full charge.

Gage	Life for continuous use
4 points of tie bar gage	Approx. 4 hours

Since the continuous duty time changes depending on the conditions such as environmental temperature, lighting of back-lit and charge frequency of the battery, etc.

In due course, just think them as an aim.



Warning

When the instrument is operated with built-in battery, care should be taken as follows:

If you neglect, there may cause unexpected damage on the battery or failure on the instrument.

- When the instrument is preserved for a long time and not in use for a long time or applied with the AC adaptor only, the electrical charge and discharge should be made at least once or more in 6 months.
- When the instrument is preserved with the condition of blinking the battery empty mark, the performance on the battery may degrade.



The interval starting from blinking the battery empty mark to turning off the power supply for the instrument automatically will be approx. 40 min in case of continuous use.

When the operating life is extremely short even if the battery is recharged properly, just consider that the battery life is out.

6. Trouble shooting

When abnormal operation is found during the operation of the instrument, check it according to the following procedures. However, when applicable item can't be found, nor symptom of trouble can't be solved, contact Minebea.

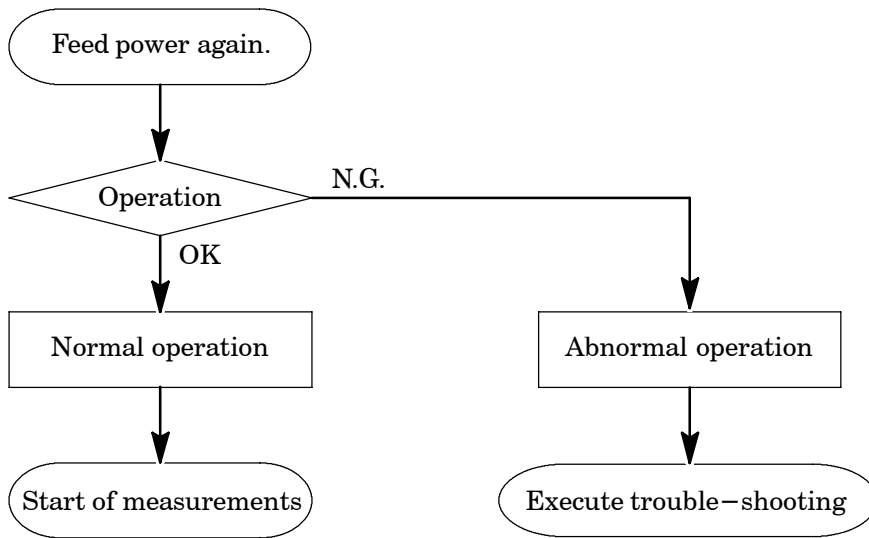

6-1. Executing trouble shooting

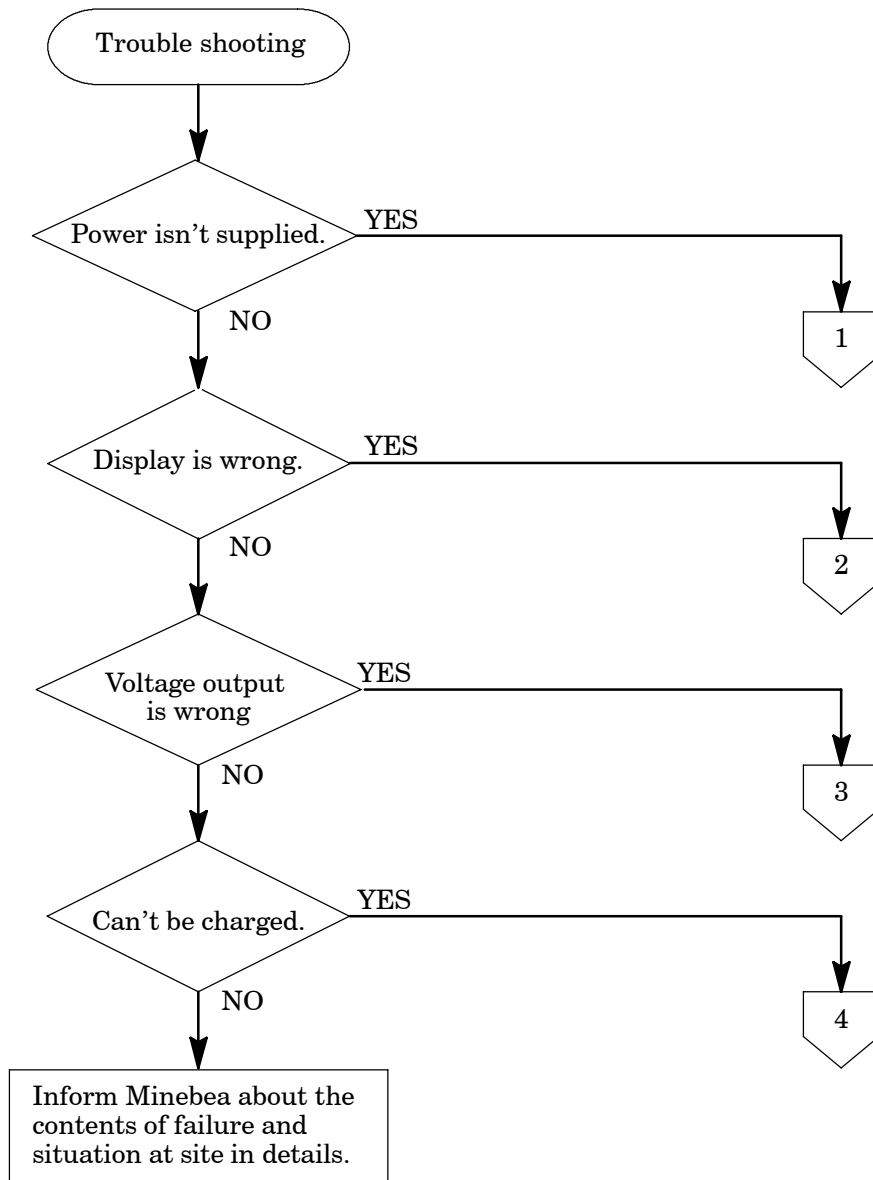

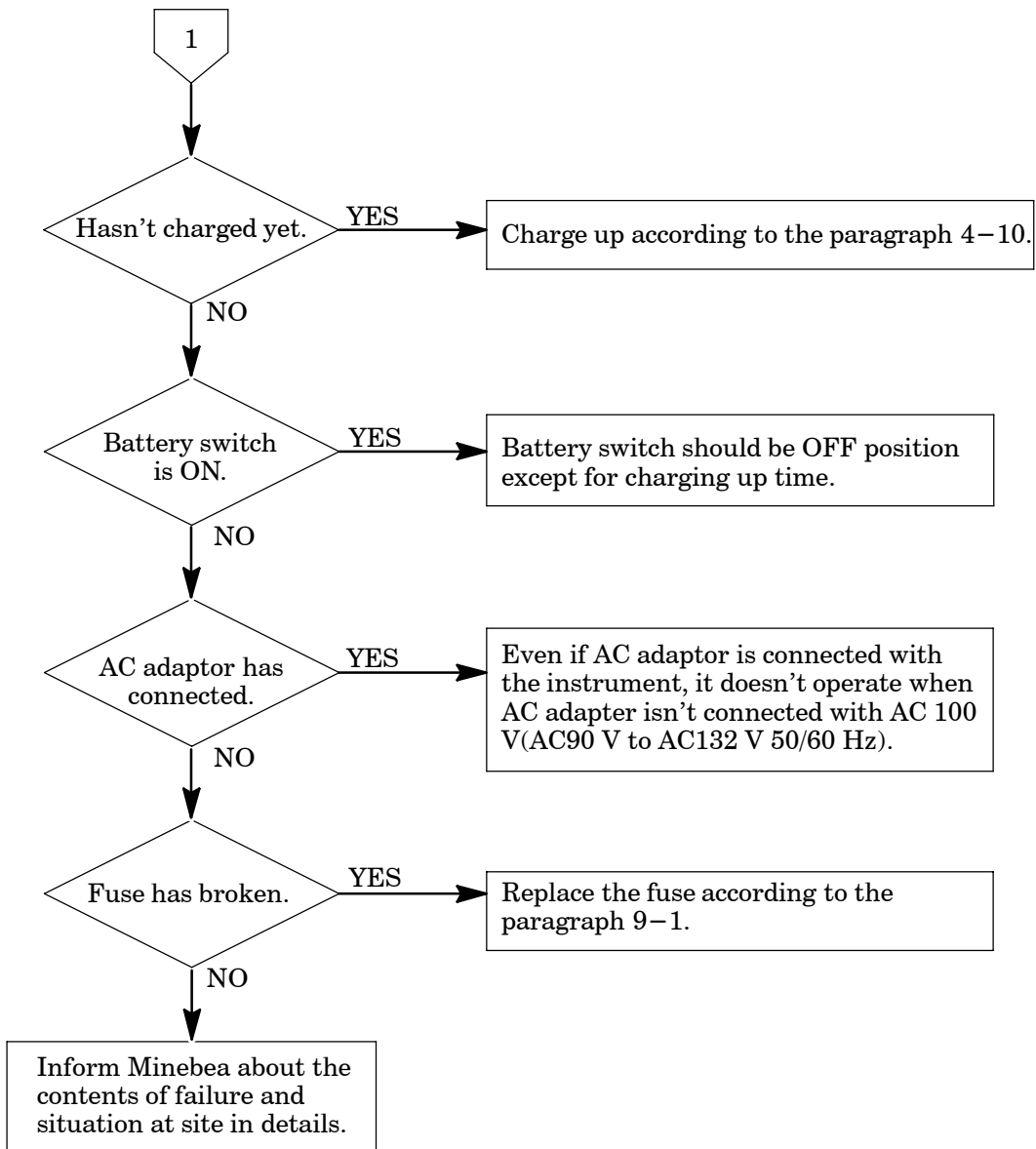

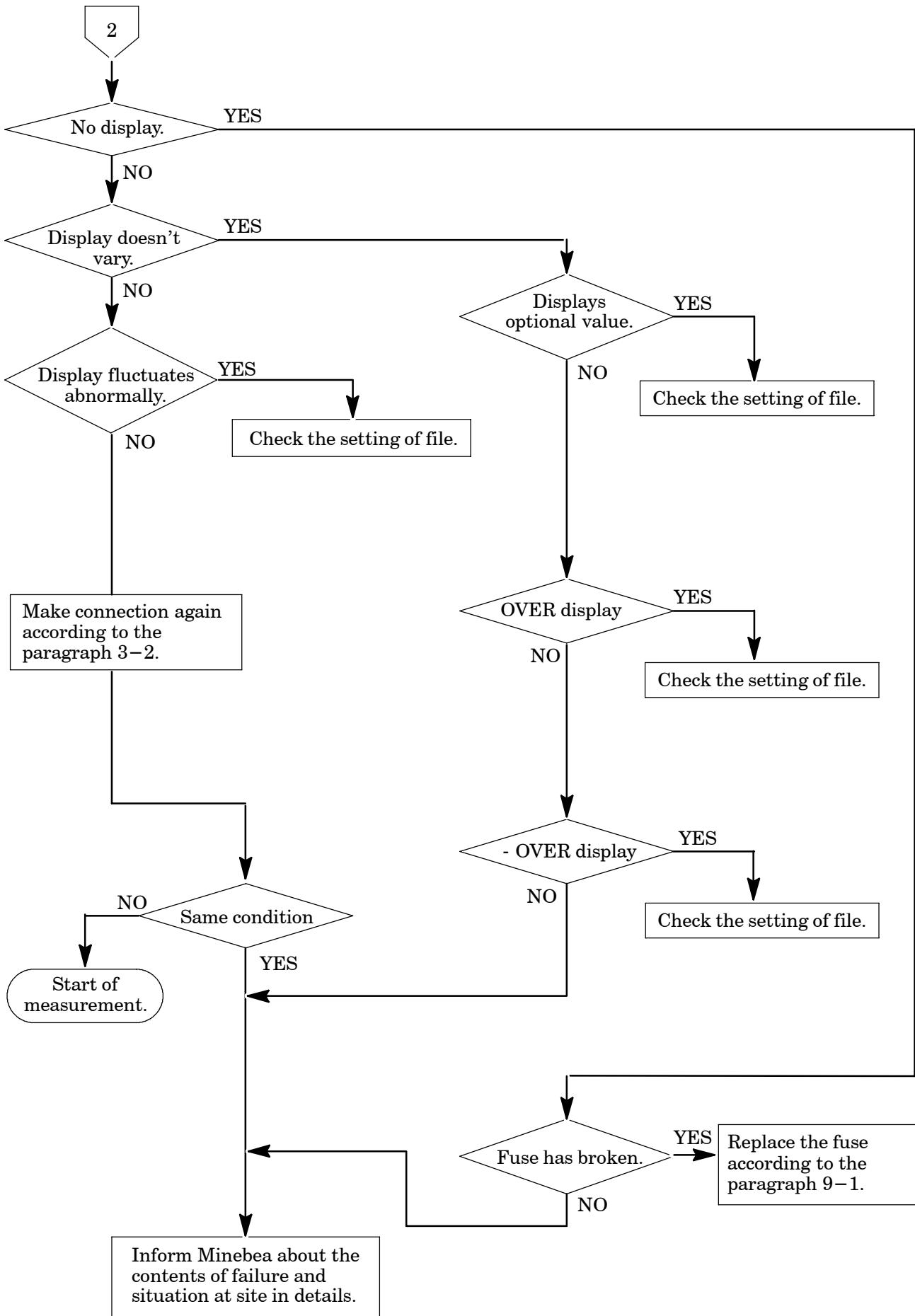

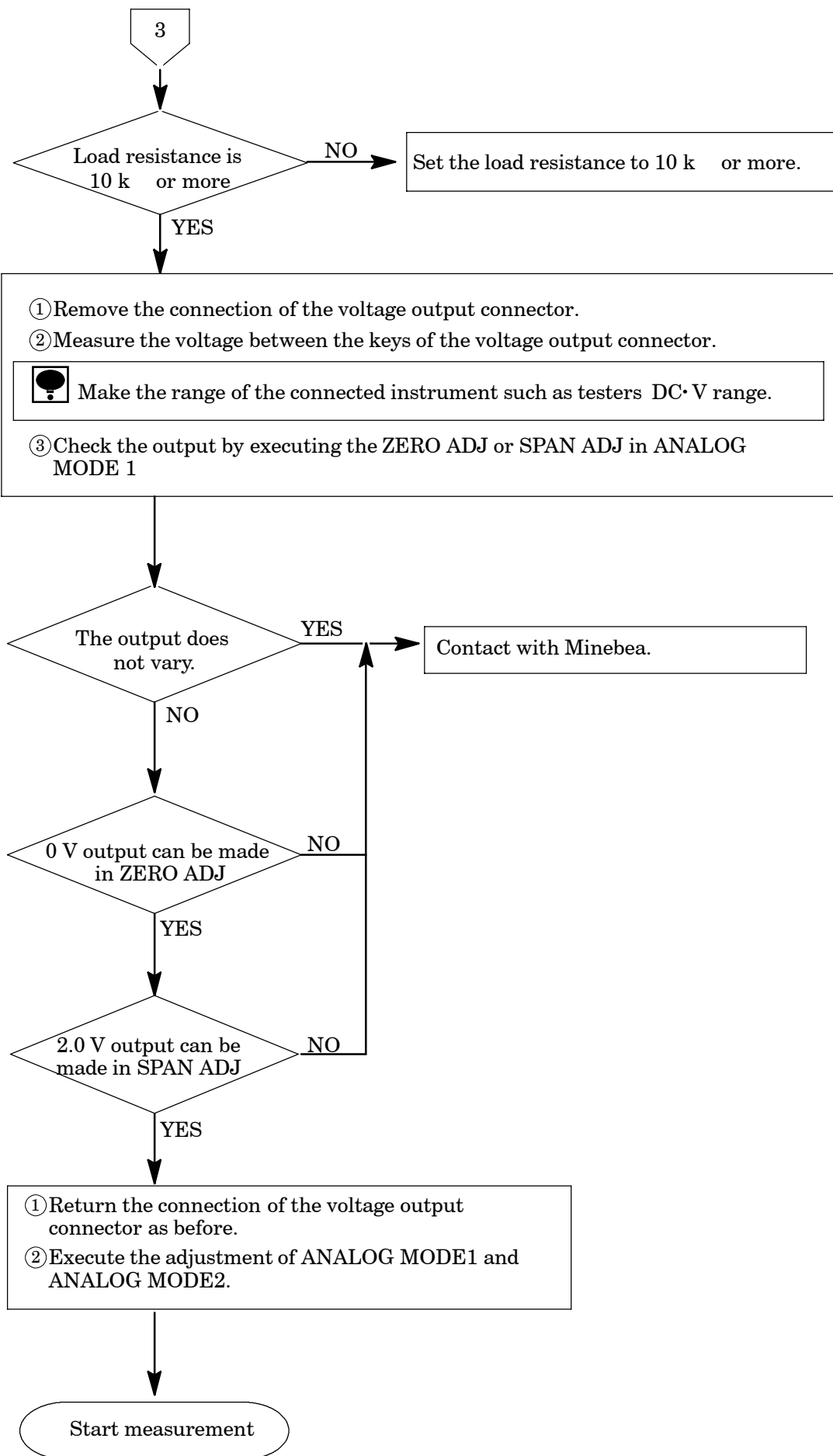

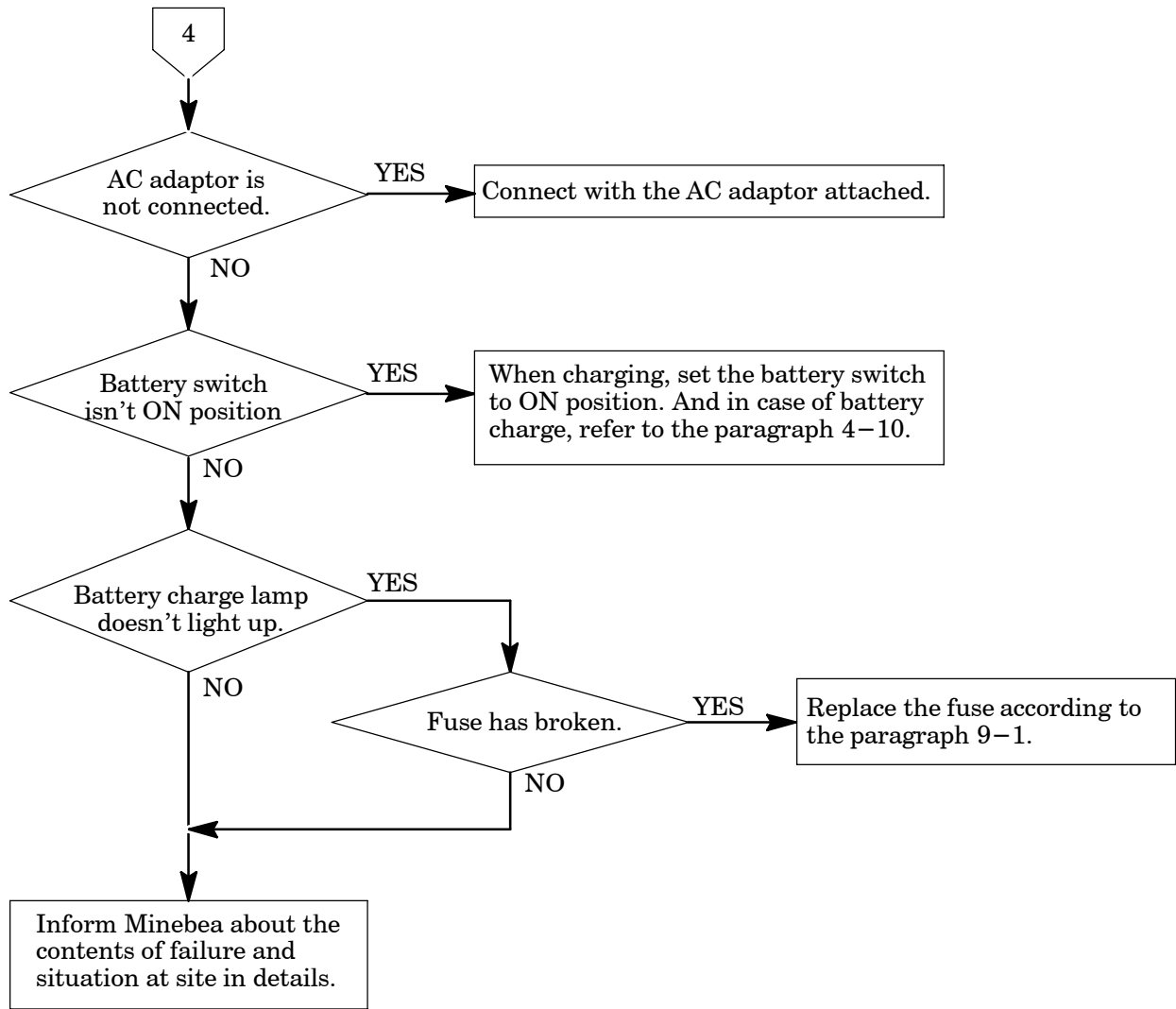

6-2. Error display

Error code	Contents of error	Remedy
E-01	Error in backup (Content of SRAM has broken.)	Press the  key. The Measurement mode can be entered. When this error code is shown at every time of powered ON, contact with Minebea. The function setting, the file setting, the status setting, and the calibration setting return to the initial value. Please set them again.
E-02	EEPROM error	Contact with Minebea.
OVER	Displays when the strain input exceeds the range, or when the load exceeds the display range.	Remove the load of the tie rod gage when it has been generated by the strain display. When it has been occurred in the load display, review the setting of the file mode, or set it within the range where the display of the load calibration can be done in the LCAL mode.
- OVER	Displays when strain input is below the range, or when the load is below the display range.	

After the power supply is turned on, E-01 and E-02 are displayed as follows.

(1) Display of E-01

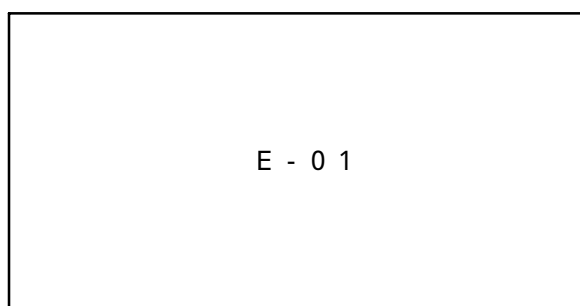

(2) Display of E-02

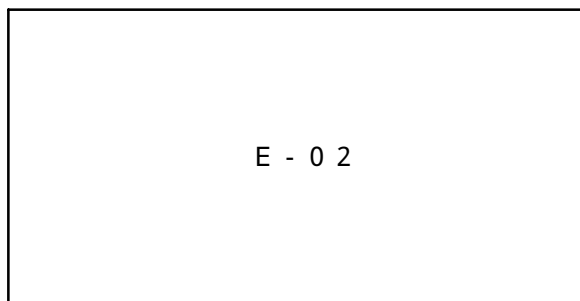

7. Specifications

7-1. Specifications for analog section

- Bridge power supply DC 2 V \pm 0.02 V, within 35 mA
- Target for measurement Tie bar gage (350 type)
- Measuring method Deflection method
- Temperature coefficient
 - Zero point $\pm 0.2 \times 10^{-6}$ strain/
 - Sensitivity ± 0.01 %F.S./(After 15 min of warming up time with the range of $\times 1$)
- Effect due to time variation
 - Zero point $\pm 0.2 \times 10^{-6}$ strain/8 h
 - Sensitivity ± 0.01 %F.S./8 h(Temperature variation width is within ± 2 with the range of $\times 1$)
- A/D sampling 16 times/s

7-2. Specifications for digital section

- Display section Dot matrix type liquid crystal display(With back-lit LED type).

7-3. File setting function

- Numbers of files 20 files at maximum
- Setting details Young ratio, Tie bar diameter(round bar),
Decimal point position, Unit(kN、MN)

7-4. Analog output

- Analog output Tie bar output : 4, Tie bar average output : 1 (BNC connector)
- Output 0 V to ± 2 V (Load resistance 10 k or more)
- Accuracy 0.5 %F.S. (Resolution 1/2 000)

7-5. Specification for measurement

- Target of measurement Tie bar gage (350 type)
- Numbers of measurement 4 pieces at maximum (1 couple for 2 pieces)
- Measurement range $\pm 15\,000 \times 10^{-6}$ strain
- Resolution 1×10^{-6} strain
- Accuracy ± 0.1 %F.S. ± 1 digit

7-6. General specifications

- Operating temperature/humidity range
 - Temperature 0 to 50
 - Humidity Less than or equal to 85 %R.H.(Non condensing.)
- Power supply
 - Power supply voltage AC90 V to 132 V(With the application of AC adaptor) or battery drive through Ni-Cd battery.
 - Power supply frequency 50/60 Hz
 - Power consumption Approx. 8 VA(When AC adaptor is used.)
- Insulation resistance Between power supply line and the case :
DC500 V 100 M or more
- Withstand voltage Between power supply line and the case :
AC1 500 V for 1 min
- Vibration proof 3 m/s²
- Resist to impact 5 m/s²
- Outline dimensions(W × H × D)
220 mm × 160 mm × 49 mm (Excludes protruding parts.)
- Weight Approx. 1.8 kg

7-7. Accessories

- Instruction manual 1 piece
- AC adaptor 1 piece
- Midget fuse(2 A) 1 piece

7-8. Outline dimensions

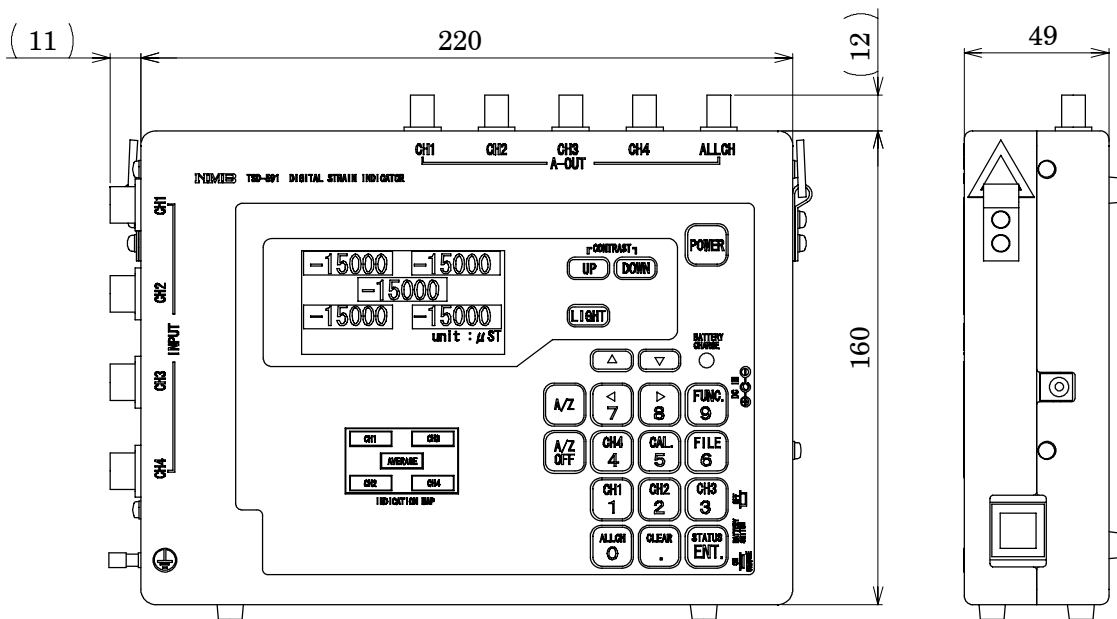

Unit : mm

8. Warranty

8-1. Warranty

- The instrument is covered by a warranty for a period of one year from the date of delivery.
- As for repairs and/or after service is required during the period of warranty, contact Minebea's sales office or sales agency from which you have purchased.

8-2. Repair

Before asking repairs, make checks once again that the connections, setting and adjustment for the instrument have finished properly by referring to the Section 6. Trouble-shooting .

Especially, make checks whether the connections of strain gage or strain gage applied transducer are disconnected or cut off.

After that, still there may be found some defects in the instrument, contact Minebea's sales office or sales agency from which you have purchased.

9. Appendix

9-1. Replacement of fuse

 **Warning** When installation method for the fuse is wrong and/or capacity of installed fuse is inadequate, it causes an unexpected faulty of the instrument.

- ① Turn off the power supply for the instrument. Moreover, remove the AC adapter if installed.
- ② Strain gage or strain gage applied transducer which is connected with the instrument, should be removed from input terminal or input connector.
- ③ Remove the 4 pieces of screws from the side panel.

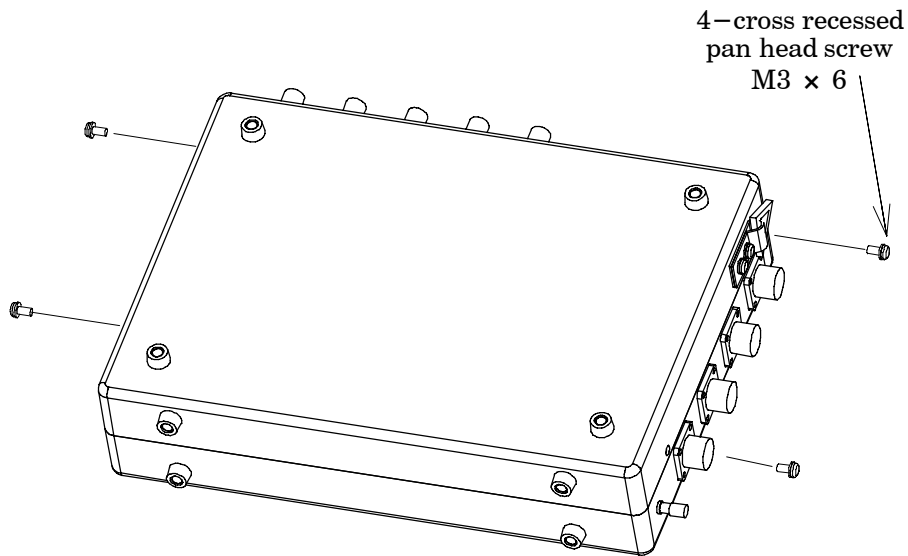

- ④ Open the rear cover slowly.
Remove the cable at connector section that connects battery and main body by hand.

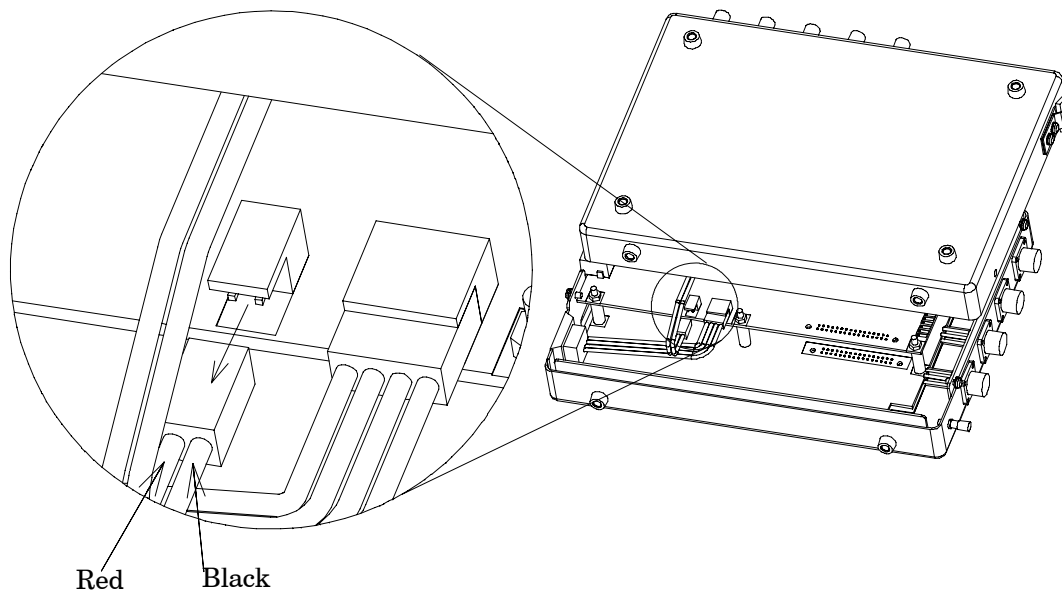



Warning

When opening the rear cover, make it slowly. If it is opened so strongly and suddenly, it may cause the cable to disconnect/cut which connects the battery attached on the rear cover and main body, so it will become useless.

When disconnecting the cable, if you remove it by pulling the cable without holding the connector section, it may cause the cable to cut, so it will become useless.

Be sure to replace the fuse with the cable disconnected, which connects the battery and main body.

If neglected, it may cause an electric shock to the operator.

⑤ Replacement of fuse

Replace the fuse attached to the panel board in the below figure.

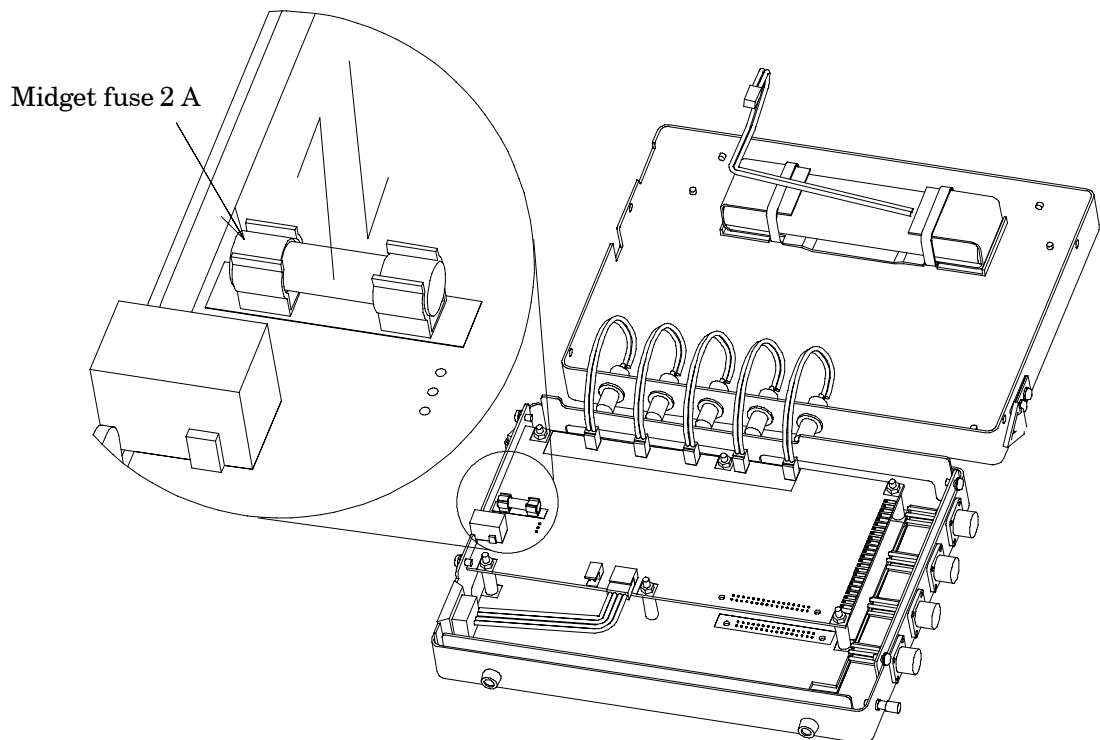

⑥ Connection with connector

Connect with the main body with the protruding section of the connector upward position.

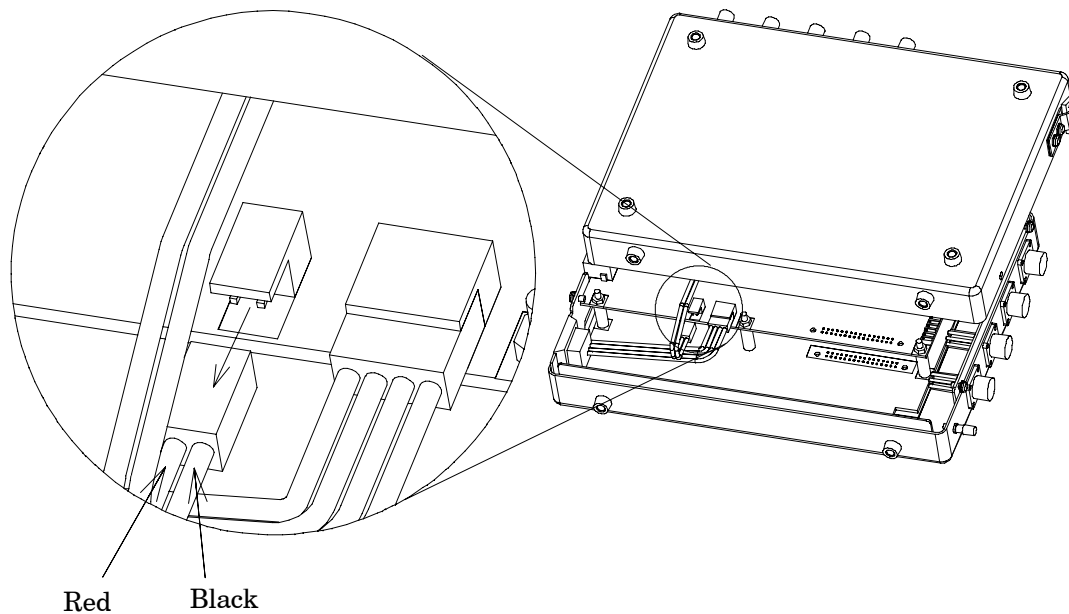

Warning

Don't touch the parts on the P.C. board other than the fuse.
It may cause a degradation of the accuracy and a malfunction of the instrument.

⑦ After replacing the fuse, fix the rear cover with the 4 pieces of screws.

4-cross recessed
pan head screw
M3 × 6

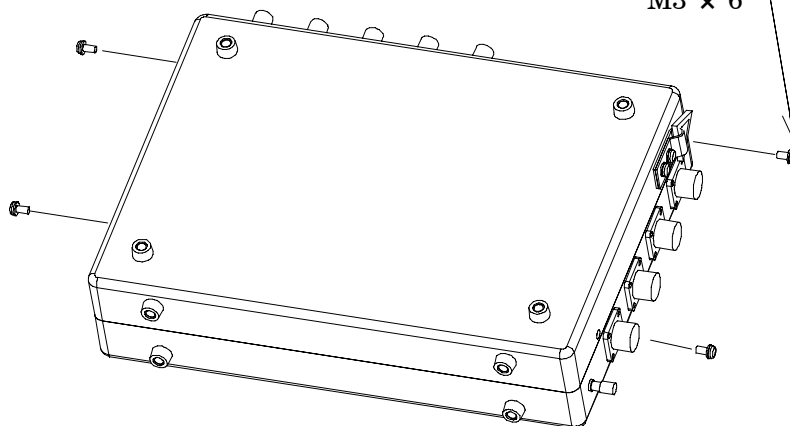

Warning

When installing the rear panel into the case, care should be taken not to insert the cable between the battery and main body. If inserted, there may cause the failure and/or damage on the instrument due to cutting the cable and so on.

- The contents of this manual may subject to change without notice.

HEAD QUARTER : **MINEBEA CO., LTD.**

4106-73 Miyota, Miyota-machi, Kitasakugun, Nagano-ken 389-0293, Japan

☎0267-32-2200 FAX.0267-31-1350

Measuring Components Business Unit

FUJISAWA PLANT 1-1-1, Katase, Fujisawa-shi Kanagawa-ken, 251-8531 Japan

☎0466-22-7151 FAX.0466-22-1701

KARUIZAWA PLANT 4106-73 Miyota, Miyota-machi, Kitasakugun, Nagano-ken 389-0293, Japan

☎0267-31-1309 FAX.0267-31-1350

HOME PAGE ADDRESS **<http://www.minebea-mcd.com>**