

***Minebea***

MINEBEA CO., LTD.

Instruction manual

DC DYNAMIC STRAIN AMPLIFIER  
**DAS-406B**

Note: Please read this Instruction Manual carefully before use.

Be sure to follow the items that require attention described in the Manual.

Keep the Manual at hand so that you can pick it up read it as soon as necessity requires.

EN294-1046D

RECORD OF REVISION

DATE	INSTRUCTION MANUAL NO.	REMARKS
JUL. 1996	DRW. NO. 294-1046	First version
FEB. 1996	DRW. NO. 294-1046A	Due to classification documents of ISO.
APR. 1999	DRW. NO. EN294-1046B	Due to FN99-2056 : "Recycled papers"
DEC. 2003	DRW. NO. EN294-1046C	Due to FN03-02176 -Addition- Notes for external control is added.
NOV. 2010	DRW. NO. EN294-1046D	Due to FN10-02140 Minebea logo is changed.

----- **FORWARD** -----

Thank you very much for your purchasing Minebea's DC DYNAMIC STRAIN AMPLIFIER DAS-406B. This Manual explains installation procedure and connecting method and operating method for DC DYNAMIC STRAIN AMPLIFIER DAS-406B.

Use properly after reading through the Manual carefully.

This manual is intended for technical experts to read.

Be sure to deliver the manual to the end user.

Moreover, the end user should keep the manual close at hand after reading it over.

- \* The contents of the Manual may subject to change without notice.
- \* The instrument is covered by a warranty for a period of one (1) year from the date of delivery.

For safe operation

Be sure to read this Instruction Manual before use.

## 1. Installation place



Use the instrument where the temperature/humidity specifies within the range as follows :

Environmental temperature :  $-10 \sim 50^{\circ}\text{C}$

Environmental humidity : Less than 85 % R. H. (Non-condensing.)

### (1) Places where installation is not allowed.



**Warning** • Do not install the instrument on the places such as follows :  
It causes unexpected faulty of the instrument.

- Do not locate the instrument in direct and/or high temperature area.
- Do not use the instrument in a high humid area.
- Do not install the instrument where there is high mechanical vibration.
- Do not use the instrument where there is excess of dust and fine particles.
- Do not install the instrument where there is rapid change of temperature and humidity.
- Do not install the instrument near the devices that become magnetized or generate electromagnetic waves.
- Avoid the location where chemical reaction may cause, such as laboratory or like that.

(2) Installing the instrument



When installing the instrument, secure the space around the instrument.



**Warning** In order to prevent from damage to the instrument and electric shock to the operator, be sure to check the following item.

- Be sure to check that power supply is off when installing/removing the power supply cable or connecting cable.

2. As for power supply



**Warning** It's very dangerous for you to operate electric instrument, so take care of yourself not to be injured.

- Permissible range for power supply voltage is AC90 V~110 V. (50/60 Hz)  
(Standard voltage is AC100 V.)
- Be sure to check the indication for power supply voltage for the instrument.  
If you find unclear points, please contact with Minebea.

\*\*\* CONTENTS \*\*\*

	(page)
① General .....	1
①-1 Features .....	1
② Each name and function	
②-1 Front panel .....	2
②-2 Rear panel .....	3
③ Connections	
③-1 INPUT connector .....	4
③-2 OUTPUT, MONI connector .....	5
③-3 POW connector .....	5
③-4 Example of connection .....	6
③-5 Note for connections .....	6
④ Preparations prior to measurement	
④-1 Setting of bridge voltage .....	7
④-2 Error due to lead wire .....	7
⑤ Adjustment prior to measurement .....	10
⑥ Calculation of strain	
⑥-1 Calculation method from recorded waveform .....	13
⑥-2 Compensation for G.F. (gage factor) .....	13
⑦ Various kinds of changes	
⑦-1 Exchanging fuse .....	14
⑦-2 COM, GND terminal .....	14
⑦-3 Trimmer for display (Interlocked with MONITOR) .....	15
⑧ Constructions .....	16
⑨ Frequency, phase characteristics .....	16
⑩ Specifications .....	17
⑩-1 Outline dimensions .....	18
⑩-2 Accessories .....	18
⑪ Warranty, repair	
⑪-1 Warranty .....	18
⑪-2 Repair .....	18

APPENDIX 1 (Example of measurement)

APPENDIX 2 (Instruction manual for Bridge box BH-120B)

## 1 General

---

DC dynamic strain amplifier DAS-406B can be used for the measurement of physical dynamic phenomena such as strain, stress, pressure, torque, vibration, and acceleration and also used for the wide application, such as simple type amplifier for instrumentation.

### 1-1 Features

① High sensitivity and wide range of frequency characteristics

The instrument prepares high sensitivity of 5000 times and wide range of frequency characteristics of DC~200kHz.

② Calibration value with 4 digits of digital code SW.

The instrument can set with a step of  $1\mu\text{st}$  between  $1\mu\text{st}$  ~9999 $\mu\text{st}$  by using 4 digits digital code SW on front panel.

③ Monitor of digital display

The instrument adopts 3 1/2 digital display at the monitor of output voltage, and monitoring of 10mV can be available.

④ Electronic auto-balance function

By pressing the "AUTO" button, initial balance up to  $\pm 5000\mu\text{st}$  can be internally cancelled automatically, so speedy measurement can be available.

Due to application of condenser type battery for auto-balanced back-up system in the instrument, functional declines due to drop-out or electric charge/discharge for a long time can be reduced.

⑤ GAIN fine adjustment trimmer

The instrument prepares GAIN fine adjustment trimmer, so it can adjust output voltage with the unit of 1mV.

⑥ 2 lines of voltage output, OUTPUT and MONI

The instrument prepares 2 lines of different voltage outputs, such as OUTPUT at rear panel and MONI at front panel.

**2** Each name and function

**2-1** Front panel

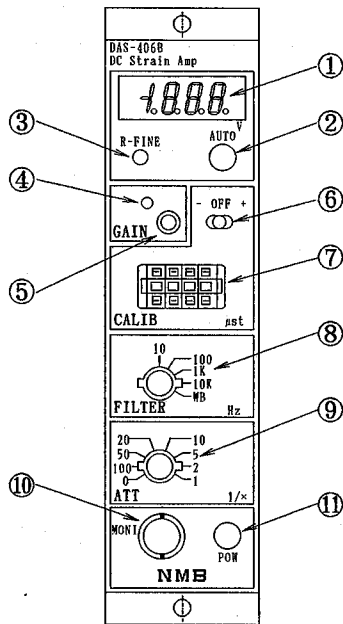

① Monitor

Output voltage of DC will be displayed digitally.

The minimum reading value is 10mV.

② Auto-balance SW

Initial R-balance can be adjusted automatically.

③ R-FINE trimmer

Used when more precise adjustment is required for initial balance.

④ GAIN trimmer (GAIN fine adjustment)

Used when fine adjustment on sensitivity is required.

⑤ GAIN adjustment volume (GAIN coarse adjustment)

From ATT×1 to 1/2.5 times can be varied lineary.

⑥ CALIB output SW

+ : Outputs calibration value of +polarity.

- : Outputs calibration value of -polarity.

OFF : Doesn't output calibration value.

⑦ Digital SW for setting calibration value

Calibration value can be set from 1 to 9999  $\mu$ st with the step of 1  $\mu$ st.

⑧ FILTER setting SW

SW for setting of cut-off frequency of low pass filter.

⑨ ATT setting SW

SW for sensitivity setting.

⑩ MONI connector (BNC)

Connector for monitoring output voltage.

⑪ POW SW

SW for input/output of power supply.

2-2 Rear panel

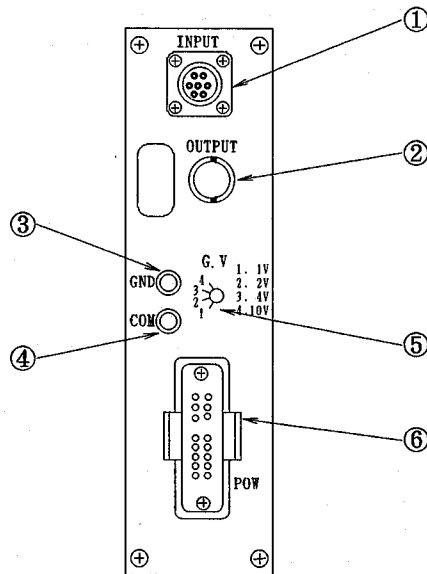

- ① INPUT connector  
Transducer or strain gage bridge can be connected.
- ② OUTPUT connector  
Connect with external equipment for the purpose of voltage output.
- ③ GND terminal  
This is connected with main body of chassis.
- ④ COM terminal  
This is connected with COM level (Electric potential) on the internal circuit.
- ⑤ Gage voltage changeover SW
- ⑥ POW connector  
Connector for power supply. \*1  
(Power supply cable is attached.)

---

\*1 When supply voltage has changed (Optional DC+12V is indicated.) connect with the specified voltage.

### 3 CONNECTIONS

#### 3-1 INPUT Connector

(Suitable plug PRC03-12A10-7M Tajimi Electronics Co., Ltd. (Separately sold.))

##### 1) Pin configuration

Pin No.	Signal name	CAB-501	CAB-502	Remarks
A	Bridge power supply +	red	red	EXC. +
B	Amplifier input -	blue	blue	SIG. -
C	Bridge power supply +	white	white	EXC. -
D	Amplifier input +	green	green	SIG. +
E	Shield	(yellow)	(yellow)	SHIELD
F	Sensing +	orange	-	SEN. +
G	Sensing -	black	-	SEN. -

##### 2) Connection with transducer

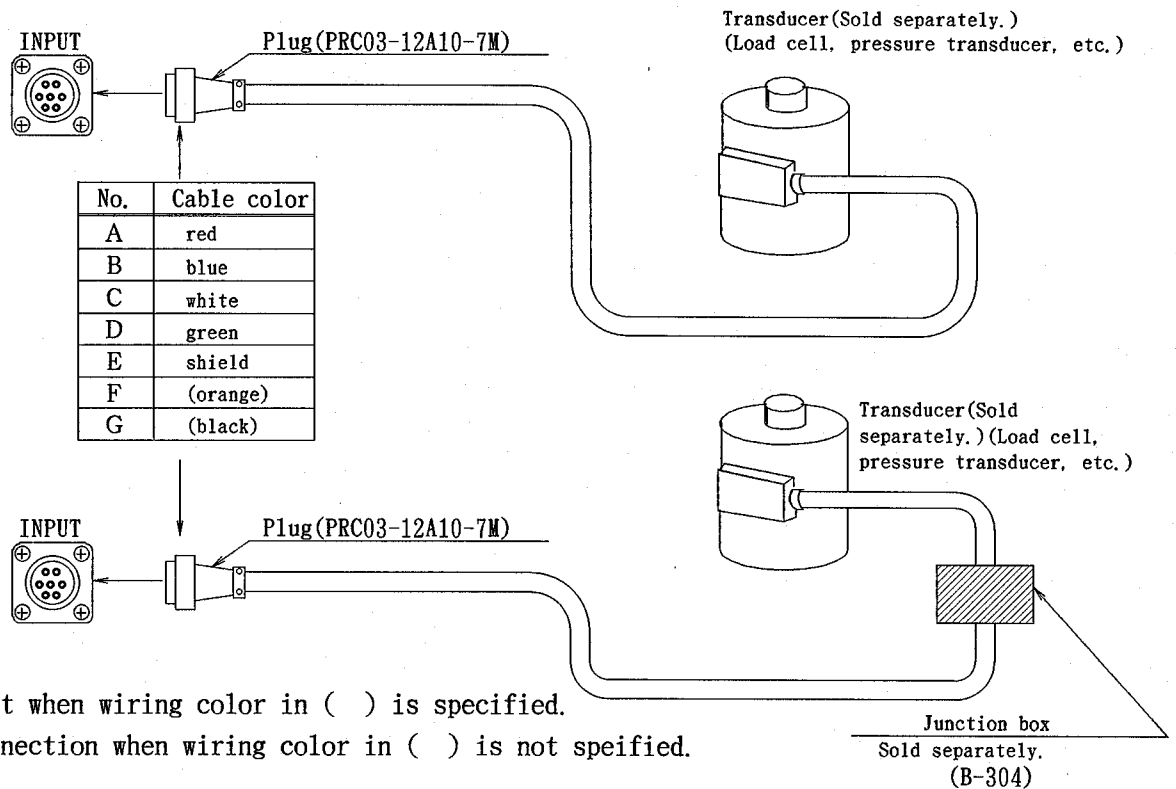

##### 3) Connection with bridge box

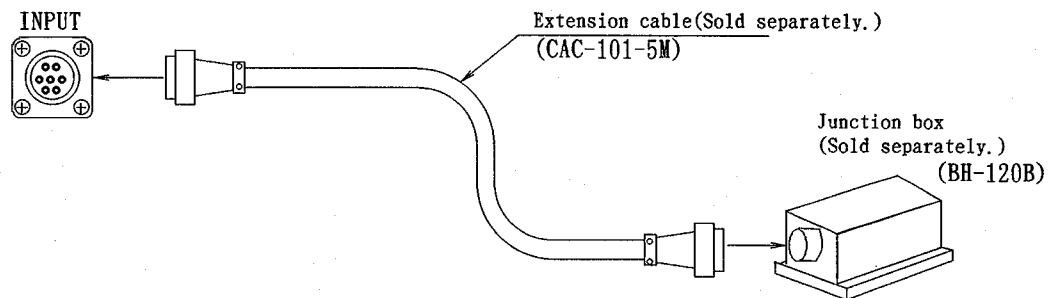

※ Refer to Appendix 2, as for the application method of Bridge box.

**3-2 OUTPUT, MONI Connector**

[Suitable plug : BNC general type (Separately sold.)]

1) Pin configuration

	Load resistance	Capacity load
Center of connector : ⊕ of output	OUTPUT : 330Ω or more	0.1 μF or less
Edge of outer side (Metal) : ⊖ of output	MONI : 2kΩ or more	0.1 μF or less

**3-3 POWER connector**

[Suitable cable with plug : CAC-005-2m (Attached)]

1) Pin configuration

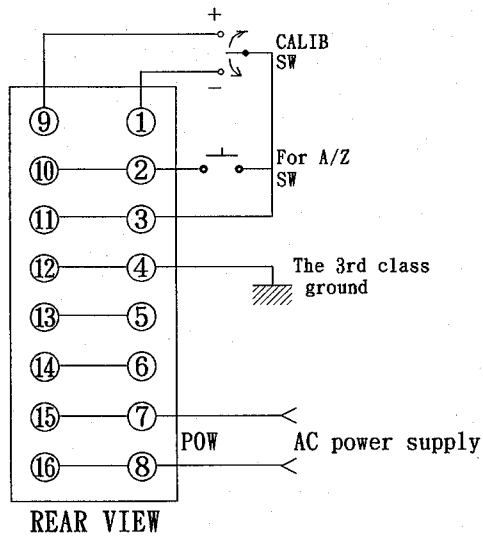

- ① : Minus CALIB external input terminal
  - ⑨ : Plus CALIB external input terminal
  - ⑩ ② : AUTO ZERO external input terminal
  - ⑪ ③ : COM terminal of CALIB & AUTO ZERO
  - ⑫ ④ : The 3rd class (GND) terminal  
(Connected with main body of chassis.)
  - ⑮ ⑦ : Connecting terminal of (AC)AC power supply.
  - ⑯ ⑧ : Connecting terminal of (AC)AC power supply.
- Other than the pins as above are not used.  
Standard product corresponds to 100VAC±10%.

In case of optional 12VDC

⑮ ⑦ : Connecting terminal of DC +12V ⑯ ⑧ : Connecting terminal of DC COM

**⚠** When the condition changes by the external control, check the timing at the time of change with the instrument (amplifier) thoroughly and also adjust the timing by the timer process as necessity requires.

2) Connection with attached cable

Power supply cable with plug is attached.

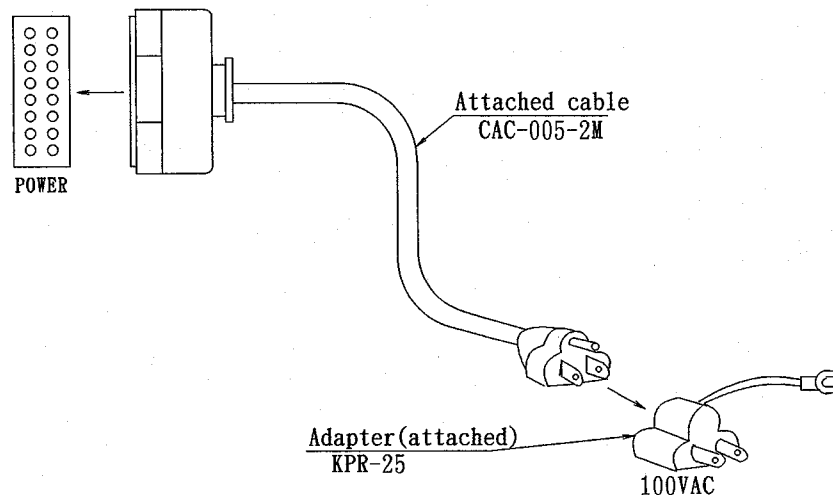



## 4 PREPARATIONS PRIOR TO MEASUREMENT

### 4-1 Setting of bridge voltage

When excitation voltage is required for transducer, strain gage and so on, set the suitable bridge voltage according to the bridge resistance to be connected as shown in the below table.

SW	Bridge voltage (V)	Bridge resistance( $\Omega$ )			
		60	120	350	1000
1	1	○	○	○	○
2	2	×	○	○	○
3	4	×	×	○	○
4	10	×	×	○	○

Note) Setting at x mark shown in the above table should be avoided. Bridge voltage shall not be excited correctly.

\* When strain gage is connected with bridge box and so on, it is considered that drift might occur due to self heat generation, so we recommend you setting of low voltage as possible. Especially, care should be taken when strain gage is attached to the object to be measured featuring few radiation of heat such as plastics, Bakelite and so on.

### 4-2 Error due to lead wire

The instrument has calibrated with 5m cable (CAB-501). In due course, when cable length is long from bridge box or transducer to the instrument, bridge voltage will decline due to conductor resistance of cable, and deviation will occur between actual bridge voltage and external bridge voltage used with calibration value (CALIB). This means that there may be cases of calculated values that include errors when calculation of actual measured value is made as calibration value (CALIB) of the instrument as standard.

As for the methods of decreasing these errors, we will explain 3 kinds of methods in this chapter.

#### 1) Compensation with calculation

##### ① Compensation for voltage drop rate

When connection with transducer and the INPUT of the instrument is made without using Junction box and so on, this method will not be applied, so make use of the table on voltage drop rate in the next page.

(Voltage drop rate  $\alpha$  (CAB-501, 502 7/0.32 0.56mm<sup>2</sup> Temperature 20°C)

Bridge resistance	Length from the instrument			
	20 m	50 m	100 m	200 m
60 $\Omega$	2.3%	5.8%	11.0%	19.4%
120 $\Omega$	1.2%	3.0%	5.8%	11.0%
350 $\Omega$	0.4%	1.0%	2.1%	4.1%
1000 $\Omega$	0.1%	0.4%	0.7%	1.5%

Note : Above is the table on voltage drop rate when Minebea's cable of CAB-501 and CAB-502 are applied.

- a) Feed power with ATT of the instrument set as 0 (zero).

Measure the voltage between A and C by attaching voltmeter's  $\ominus$  side to C and  $\oplus$  side to A at the INPUT of the instrument. (When connector is connected at INPUT, disconnect the connector after cut off power supply once.) Now, the voltage value measured here is assumed to be  $V_0$ .

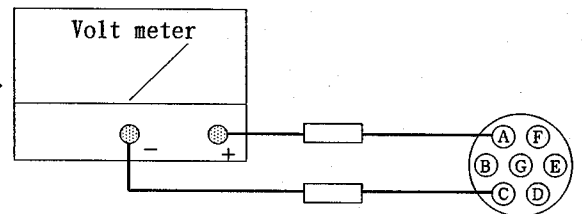

In this case, do not leave the instrument for a long time with the condition of feeding power source.

- b) Cut off the power supply, and connect connector with the INPUT of the power, then supply ON the power again.

Measure the bridge box nearest to the objects to be measured or between A-C of Junction box. The measured voltage shall be assumed to be  $V_1$ .

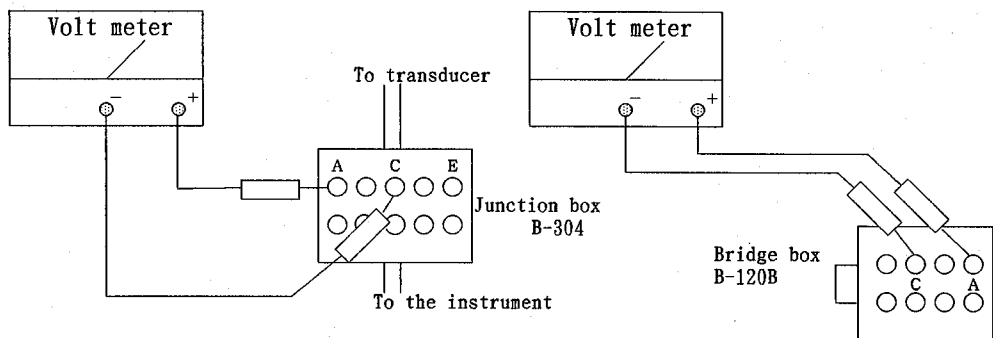

- c)  $\alpha = \frac{V_1}{V_0} \times 100$  (%)  $V_0$  : Voltage between INPUT of A-C of the instrument  
 $V_1$  : Bridge box or Voltage of between A-C of the bridge box

Obtain  $\alpha$  from the calculation or from the table, then compensate with the following formula.

$$S = \frac{S'}{1 - (\alpha)}$$

$S$  : True strain value

$S'$  : Strain value measured by the instrument

$\alpha$  : Voltage drop rate (In case of 1%, substitute 0.01.)



c) Connection of remote sensing

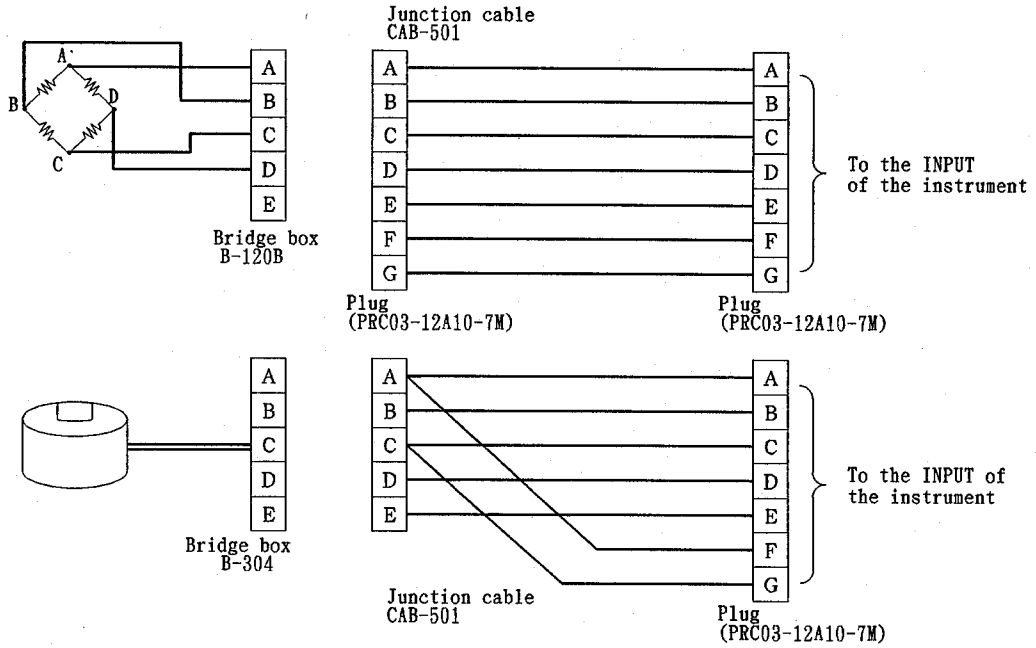

If the SW1 becomes effective without finishing connection as above, there may be causes of destroying the instrument, transducer and gages.

**5** Adjustment prior to measurement

Procedures	
<p>1. Adjust the ATT knob on front panel to indicate 0 (zero) position. Another knobs may indicate any positions. After checking the connection with INPUT, OUTPUT, MONITOR and POW, push the POW SW.</p> <p>Note) If power is supplied without adjusting ATT knob to show 0, there may cases of outputting about <math>\pm 14V</math> voltage at OUPUT, MONI and so on.</p> <p>Take full care when external equipment is connected with OUTPUT or MONITOR. There may be cases of destroying external equipment.</p>	
<p>2. After the display lights, press the AUTO button once.</p> <p>Note) After feeding power, the instrument becomes ON condition, however preliminary operation will be required for 20~30 minutes for the stable operation. Besides, in case of measurement on minute strain or long period of measurement, perform preliminary operation for one hour or so.</p>	
<p>3. In order to adjust internal off-set, adjust the R-FINE trimmer R-FINE by using the attached screwdriver so that the output voltage (OUTPUT, MONIOTR) will become 0V. By turning to the left, it shifts to minus and to the right, it shifts to plus.</p>	

Procedures

4. Push the AUTO button after adjusting the ATT to 1 position. At the same time, check that the GAIN volume turns to the Max. position. (To the right fully.) In one minute, effective to initial imbalance of connected transducer with INPUT or bridge box (connected bridge) will be eliminated. Moreover, if fine adjustment is required, apply further adjustment with R-FINE trimmer

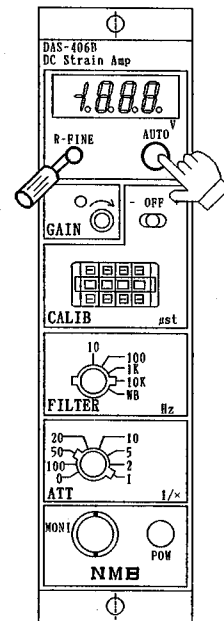

5. Set the ATT sensitivity to a suitable position corresponding to the values of input signal. GAIN will vary continuously from ATTx1~1/2.5 times, so adjust it properly.

	GAIN	Strain value that can be measured. (μst)			
		BV=1V	BV=2V	BV=4V	BV=10V
1	MAX (To the right fully.)	± 4000	± 2000	± 1000	± 400
	MIN (To the left fully.)	± 10000	± 5000	± 2500	± 1000
1/2	MAX	± 8000	± 4000	± 2000	± 800
	MIN	± 20000	±10000	± 5000	± 2000
1/5	MAX	± 20000	±10000	± 5000	± 2000
	MIN	± 50000	±25000	±12500	± 5000
1/10	MAX	± 40000	±20000	±10000	± 4000
	MIN	±100000	±50000	±25000	±10000

The instrument can adjust the voltage output to ±10V when above specified ranges of strain value is input. Moreover, the instrument can't measure the strain value that exceeds more than 100000μst. 1/20, 1/50 and 1/100 in ATT will be used when output voltage is divided. For example, when measurement is made with 1/2, output can be changed into 1/10 easily by adjusting the ATT position of 1/20.

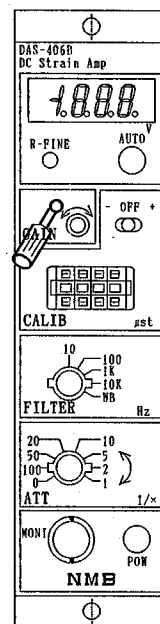

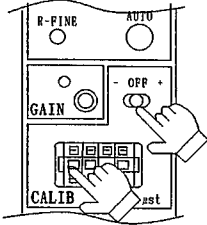
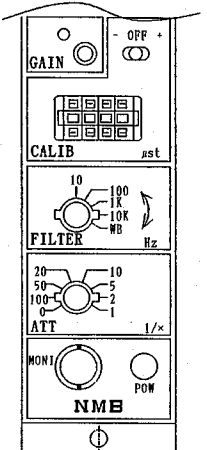
	Procedures	
6.	<p>Setting of calibration value *1</p> <p>Calibration value can be set by strain value with digital SW(CALIB) on front panel, and input can be made with the SW located at upper right. Setting range is 0001<math>\mu</math>st~9999<math>\mu</math>st and up to the unit of 1<math>\mu</math>st can be set. By pressing the CALIB SW to the right, plus value of calibration can be obtained. And by pressing to the left, minus calibration value will be obtained.</p> <p>By inputting the calibration value in the procedure of 5, measuring range can be confirmed. Moreover, input is applied as standard level before measurement, calculation of strain for the measuring object will be made. (Refer to [6]-1 Calculation of strain.)</p>	
7.	<p>Filter</p> <p>Change of cut-off frequency for low-pass filter can be made. Estimate the measuring frequency of measuring objects and also consider attenuation ratio and phase delay by referring to 「Frequency and phase characteristic graph」 shown in Page 16.</p> <p>We recommend the frequency that specifies about 2~5 times of the phenomenon to measure.</p>	
8.	<p>Measurement can be started.</p> <p>As for the example of measurement, refer to Appendix 1.</p>	

\*1 Calibration and calculation when connection is made with transducers.

In the "Test Report" attached to strain gage applied transducer, rated output value(mV/V) at the time of application of rated load will be shown.

By adjusting the rated value changing into calibration value of the instrument, physical quantity applied on the transducer will be read directly.

EX) When rated output is 1mV/V for rated capacity of PRB-10kgf/cm<sup>2</sup> is considered.

Since 2000 $\mu$ st=1mV/V, and G.V.=2V is considered, adjust 4000 $\mu$ st for the calibration value of the instrument and add the calibration value.

If you adjust the output voltage to 10.000V with ATT and GAIN, direct reading of 5.000kgf/cm<sup>2</sup> will be obtained with the output of 5.000V.

## 6 Calculation of strain

### 6-1 Calculation method from recorded waveform

To calculate strain from the recorded waveform of recorder, obtain it from the proportional relations between recorded curves and calibration lines. That is, with the zero position as a reference, the distance from the reference to the recorded curves should be compared and calculated.

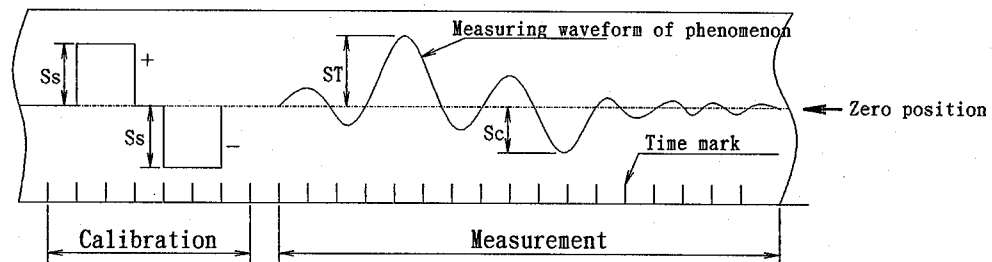

Calibration value	Amplitude of $S_s$ ( $\mu st$ )	: $S_{mm}$
Measured value	Amplitude of $ST$ ( $\mu st$ )	: $T_{mm}$
Measured value	Amplitude of $Sc$ ( $\mu st$ )	: $C_{mm}$
Max. strain at plus side	$ST = S_s \times \frac{T}{S}$	( $\mu st$ )
Max. strain at minus side	$SC = S_s \times \frac{C}{S}$	( $\mu st$ )

\* Continuous time of phenomenon and time from the start of phenomenon can be calculated from the time mark easily.

### 6-2 Compensation for G.F. (Gage factor)

The instrument is adjusted as G.F. (Gage factor= 2.00) for strain gage.  
If other than the gage is applied, calculate from the following formula.

$$S = S' \times \frac{2.00}{K}$$

S : True strain value

S' : Strain value measured with the instrument

K : G.F. of gage applied

## 7 Various kinds of changes

### 7-1 Replacement of fuse

By removing the chassis cover (Fixed with M2.6×5 4 pcs of screws.) at the right side facing the Front, parts surface on P.C. board will be appeared.

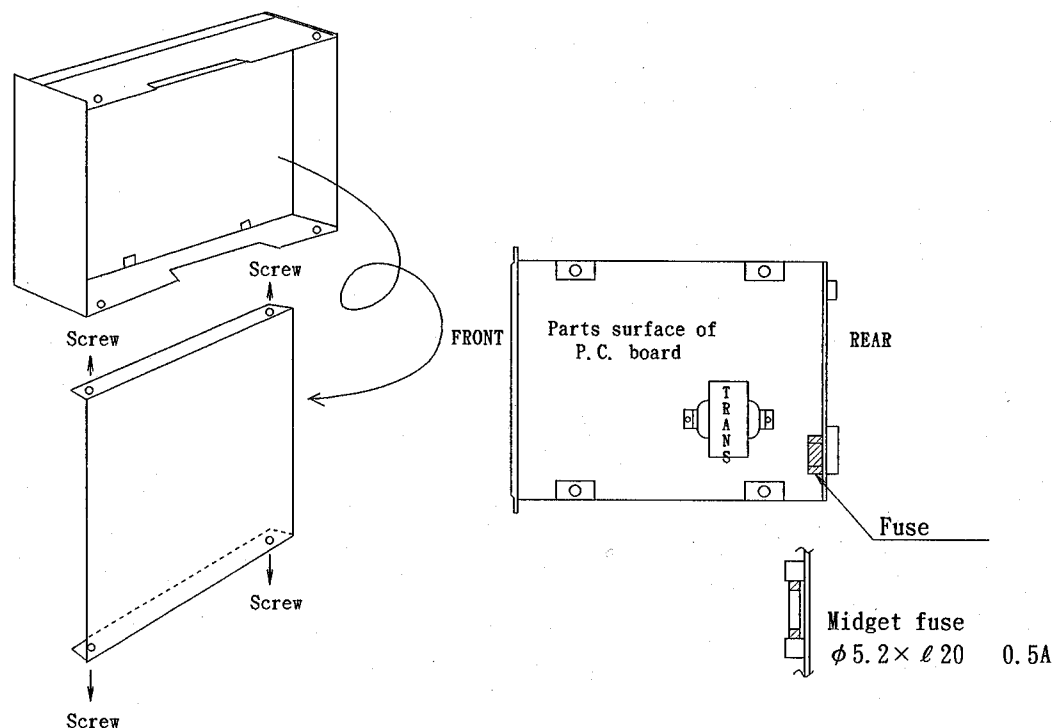

Note) When fuse is blown out, replace with a new one after its cause has checked.  
If the fuse blows out again, contact our Sales/Representative office.

### 7-2 COM, GND terminal

COM terminal on the Rear panel are equipotential with standard electrical potential (common) on internal circuit, and GND terminal is common with main body of chassis.

If large noise is considered, good effect can be obtained by shorting with COM terminal, GND terminal and lead wire and so on and by grounding.

Besides, when application is required in the same cabinet installed with a few/several pcs of the instruments, separate the COM terminal from the GND terminal.

**7-3 Trimmer for display (Interlocked with MONITOR.)**

1) The display section of the instrument shows MONI (monitor) output, and 10.00 will be shown when the MONI output is +10V.

Monitor output can be adjusted from 1 to 1/2 with the internal trimmer of the instrument. This function can be available when the display is required to change optionally and read directly.

EX) When connection is made with the INPUT of load cell (C3P1-5TON) .

(Capacity 5TON, Rated output 3mV/V)

- Press the AUTO button with the condition of no load applied on the load cell.
- Adjust the CALIB to 6000, then input the calibration value with SW lever in order to adjust the output to 10.00.
- Turn the VR6 to the left located on the board with the attached screwdriver, and adjust to 5.00.

After above adjustment is completed, the display of 2.00 shows the load cell is applied 2 ton of load.

※ If zero(0) adjustment for display is required, adjust with R13.

The display shifts to -(minus) side by turning to the left, and + side by turning to the right.

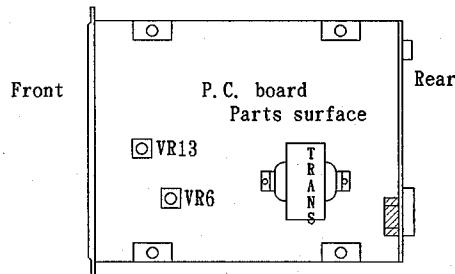

NOTE) Monitoring on AC output display section can not be executed.

2) Change of decimal point

If change of decimal point is required, change the connector attached to the Front panel to the position you want to request.

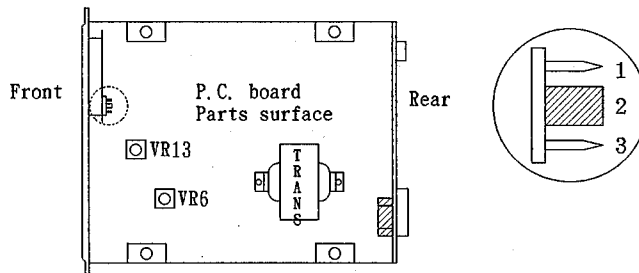

Position of connector	Decimal point	Display
Non	$10^0$	1000
1	$10^1$	100.0
2	$10^2$	10.00
3	$10^3$	1.000

## 8 Constructions

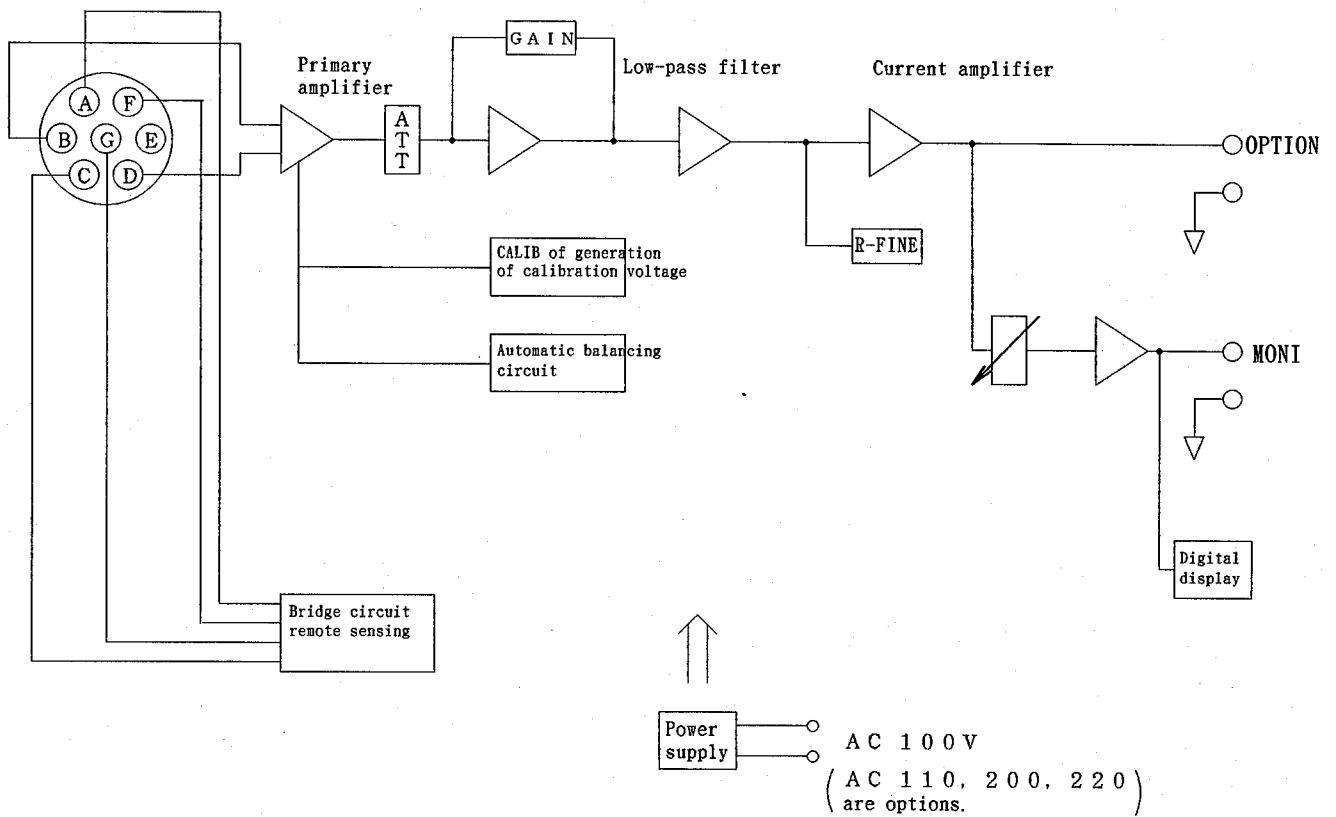

Block diagram

## 9 Frequency, Phase characteristics

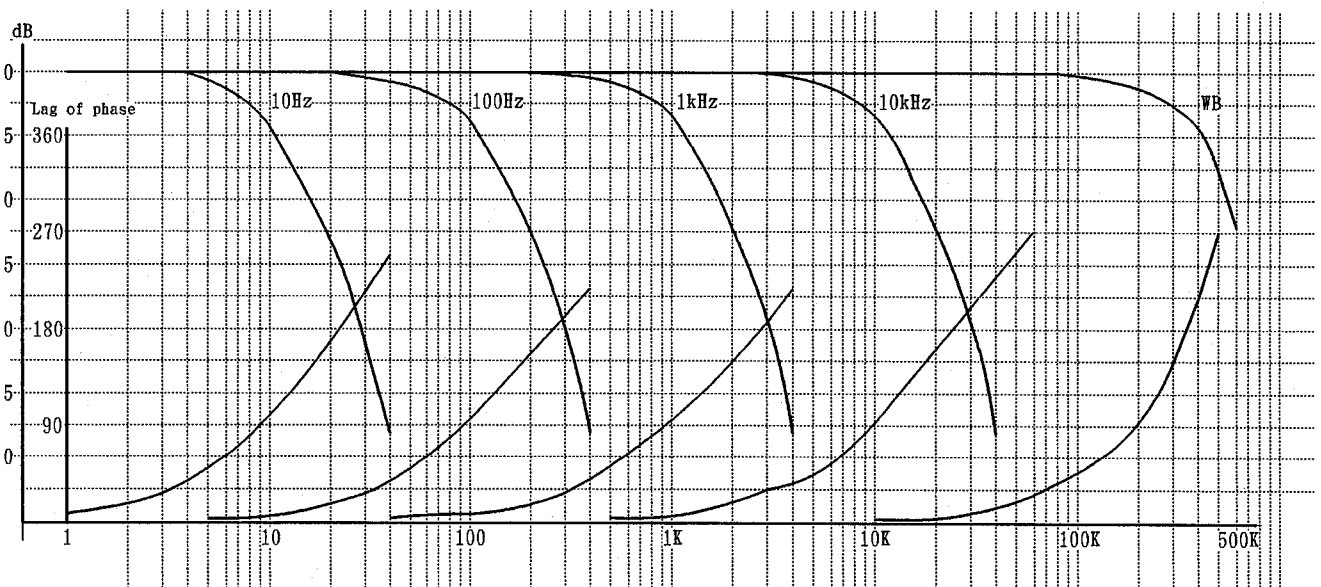

## 10 Specifications

Measuring points	1 point per 1 set
Applicable gage resistance	60Ω~1KΩ
Gage factor	2.00
Bridge power supply	1, 2, 4, 10VDC (4 steps of change) With remote sensing applied. (50mA at MAX)
Balancing adjustment range	Automatic initial balancing Automatic balancing time Approx. 1 sec. Accuracy ±0.1% F.S. Back-up time More than 24 hours
Balancing adjustment range	Effective for resistance : Approx. ±1% (Approx. $\pm 5000 \times 10^{-6}$ strain)
Sensitivity	0.5V output at the input of $100 \times 10^{-6}$ strain (B.V=2V)
Output	MONITOR ±10V, ±5mA (Load resistance 5kΩ or more) OUTPUT ±10V, ±30mA (Load resistance 330Ω or more) Output resistance 10Ω or less Capacity load 0.1μF or less
Non-linearity	Within ±0.01%F.S.
Standard equivalent strain (CAL)	Set with digital SW 4 digits± 1~9999×10 <sup>-6</sup> strain Within ±0.2% F.S. at each accuracy point
Sensitivity adjustment range (ATT)	1, 1/2, 1/5, 1/10, 1/20, 1/50, 1/100, 0 Within ±0.2%/F.S. at each accuracy point 1/2, 5×1 times continuously variable. (VAR)
Frequency response range	DC~200KHz +1dB, -3dB (Filter W/B)
Low-pass filter	10, 100, 1K, 10KHz, W/B Tertiary Bessel type
SN ratio	At WB, 46dBp-p (ATT=1) When 10Hz~10KHz, 55dBp-p
Display section	Display of output voltage 0~±10.00 3 1/2 digits digital display (LED) Sampling Approx. 4 times /SEC When the output voltage is in the field of non-linearity, 0.00 will be flashed on and off.
Stability	Effect due to temperature variation : Zero shift±1×10 <sup>-6</sup> strain/°C, Sensitivity variation±0.01%F.S./°C Variation due to time: Zero shift±5×10 <sup>-6</sup> strain/8H Sensitivity variation ±0.05%F.S./8H Effect due to power supply Zero shift ±1×10 <sup>-6</sup> strain/power supply±10% variation Sensitivity variation±0.01%F.S./power supply±10%variation
Alarm function	0.00 will be flashed on and off when the output reached out of the guaranteed range of linearity.
Remote function	Automatic balance • ±CAL
Resist to insulation	AC power supply • Case AC1500V For 1 min.
Resist to vibration	3G
Operating temperature range	Less than -10~+50°C85%RH (Excludes frozen.)
Power supply	AC100V 50/60Hz Approx. 10VA (Option) DC+12V Approx. 0.8A
Outline dimensions	176(H)×42(W)×282.5(D) (mm)
Weight	Approx. 1.5kg

**10-1 Outline dimensions**

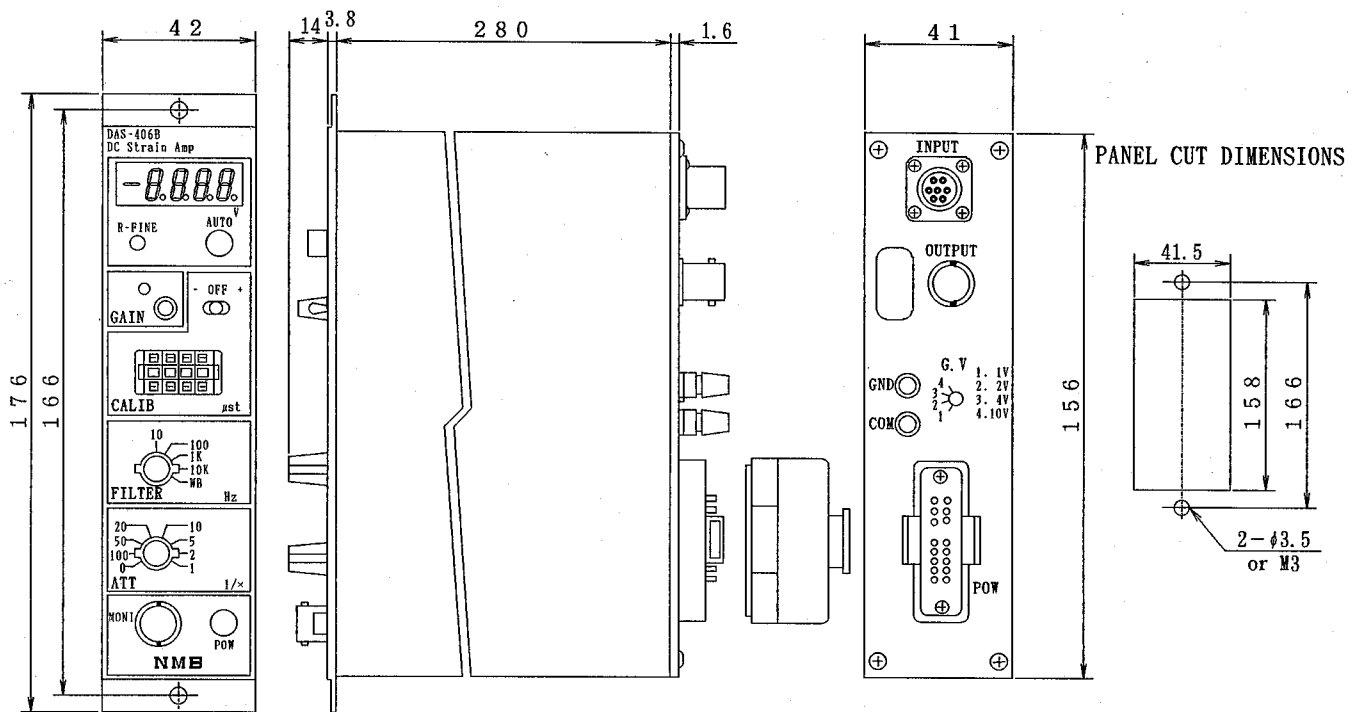

**10-2 Accessories**

- Instruction manual ..... 1 pce
- Power cable with plug attached (with adapter)(CAC-005-2M) ..... 1 pce
- Midget fuse 0.5A ..... 1 pce
- Screwdriver ..... 1 pce

**11 Warranty· Repair**

**11-1 Warranty**

- The instrument is covered by a warranty for a period of one (1) year from the date of delivery.
- As for repairs of after-service is required during the period of warranty, contact with Minebea's sales office or sales agency from which you have purchased.

**11-2 Repair**

- Before asking repairs, please make checks once again that the connections, setting and adjustment for the instrument have finished precisely.
- Moreover, make special checks whether the connections of transducers are disconnected or cut off.
- After that, still there may be found some defects in the instrument, please contact Minebea's sale office or sales agency from which you purchased.

## APPENDIX 1

---

### Example of measurement

The following is an example when the recorder is installed with the instrument (OUTPUT) and also connected with Minebea's Acceleration transducer (BAH-10G) at INPUT.

#### SW position

G. V. = 2V → For recommended excitation voltage for BAH is 3V.

Filter=1kHz → Response frequency for BAH is 0~340Hz.

If the object to be measured specified less than 340 Hz, set the set values of 100Hz and 10Hz.

GAIN → To the right fully.

ATT =1 → Since the rated output is 0.55mV/V, input of 1.1mV/V can be obtained if B. V. is set to 2V.

The positions of 2000~5000 $\mu$ st should be selected due to the condition of 1.1mV/V=2200 $\mu$ st.

#### 1. Install the Acceleration transducer (At the original position)

In order to make the initial value to zero (0), adjust to zero (0) by pressing the AUTO button.

If required, adjust to zero (0) position on the recorder together.

#### 2. After 2200 $\mu$ st is set on the front panel digital SW and press the SW to +(plus) side, then output of approx. 10V can be obtained.

Adjust with GAIN volume so that the recording pen is placed within the recorded range of recorder. During the adjustment, keep down the SW lever.

#### 3. Start the recorder and press the CALIB SW to the + (plus) side, then output value can be memorized at the time of +2200 $\mu$ st.

In the next, press it to - (minus) side to memorize the output at the time of -2200 $\mu$ st.

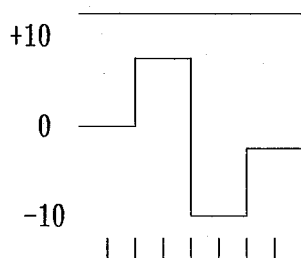

4. Start the measurement, then memorize the data.

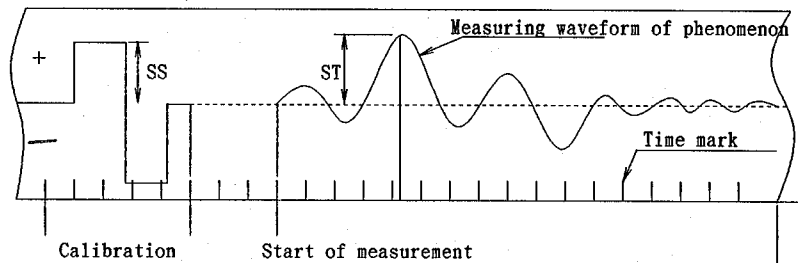

Suppose  $SS = 10\text{cm}$ , and  $ST = 8\text{cm}$ ,

then, calculation can be made as follows :

$$ST = 8G = 1760 \mu\text{st}$$

Then it is judged that variation of max. acceleration (+8G) is received after 4~5 sec. from the start of measurement.

(Refer to [6]-1 Calculation method from recorded waveform.)

## APPENDIX 2

### INSTRUCTION MANUAL FOR BRIDGE BOX (BH-120B)

#### 1. General

This is the bridge box used for the special purpose of strain measuring instrument. Built-in 3 points of resistance of  $120\Omega$  featured with high accuracy, and connecting methods with various kinds of gages can be available with the applications of terminals.

#### 2. Descriptions for each name

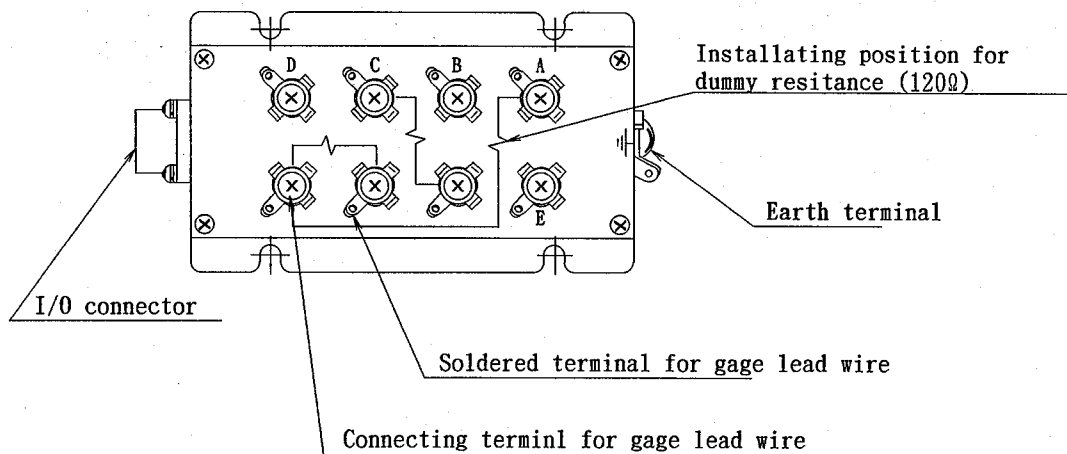

#### 3. Connector pin configuration

Input/Output connector (PRC03-21A10-7F : TAJIMI ELECTRONICS CO., LTD.)

Pin No.	Contents
A	Bridge power supply (+)
B	Output (-)
C	Bridge power supply (-)
D	Output (+)
E	Shield
F	Not used.
G	Not used.

- Terminals of A~E are connected with the terminals of A~E located at the upper section of main body.
- Shield (E terminal) is not connected with the case earth.

#### 4. Internal circuit

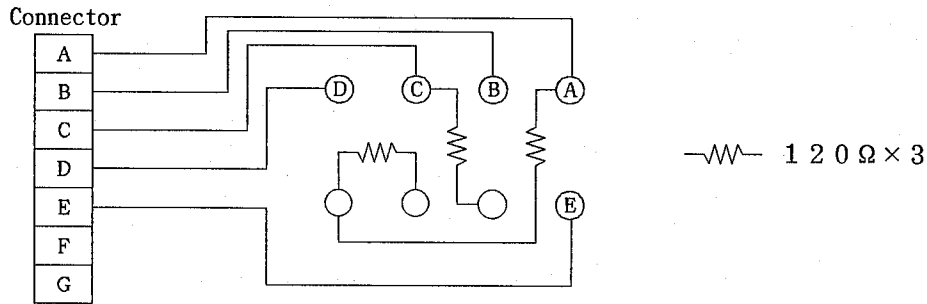

#### 5. Connecting method

##### 5-1 2 wires 1 gage method

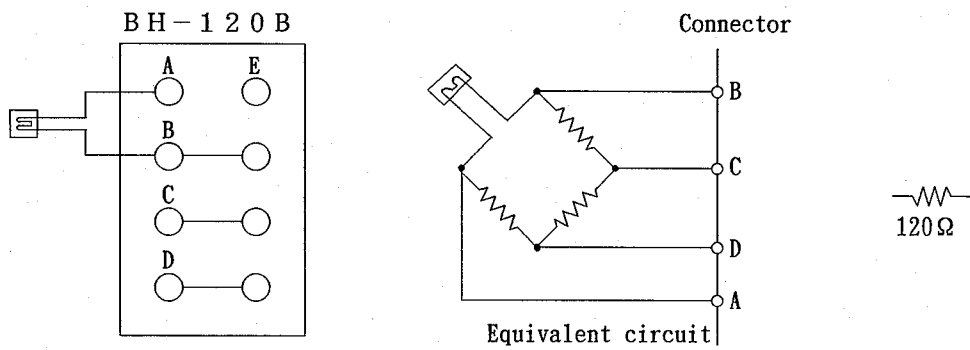

##### 5-2 3 wires 1 gage method

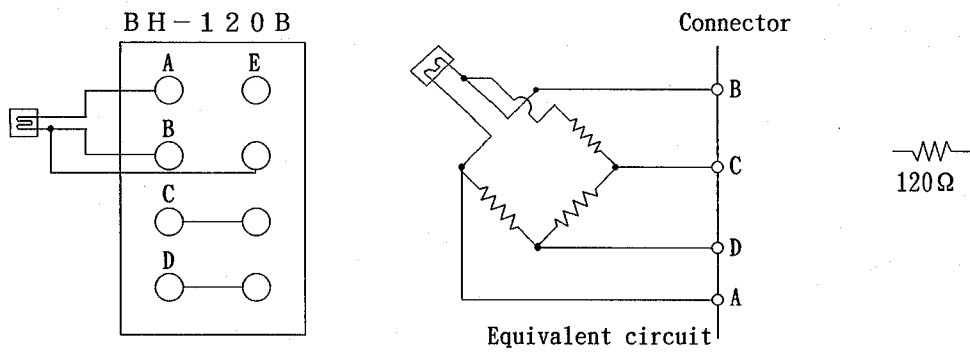

##### 5-3 2 wires 2 gage method

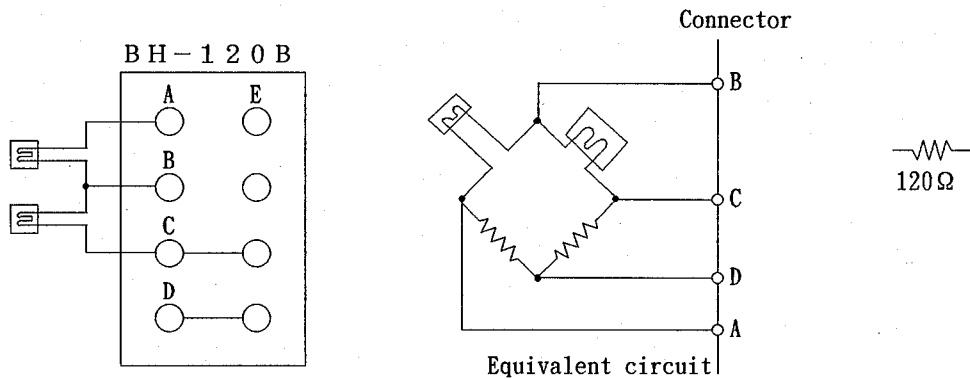

#### 5-4 3 wires 2 gage method

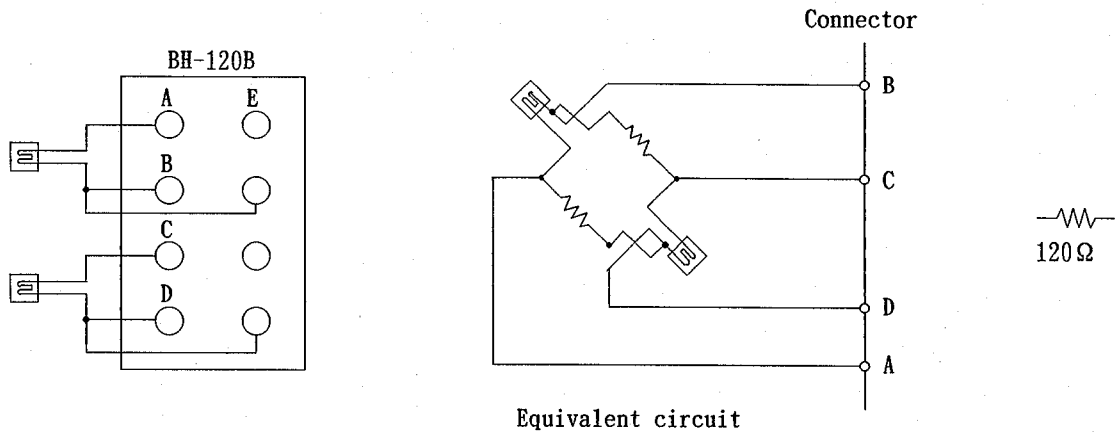

#### 5-5 2 wires 4 gage method

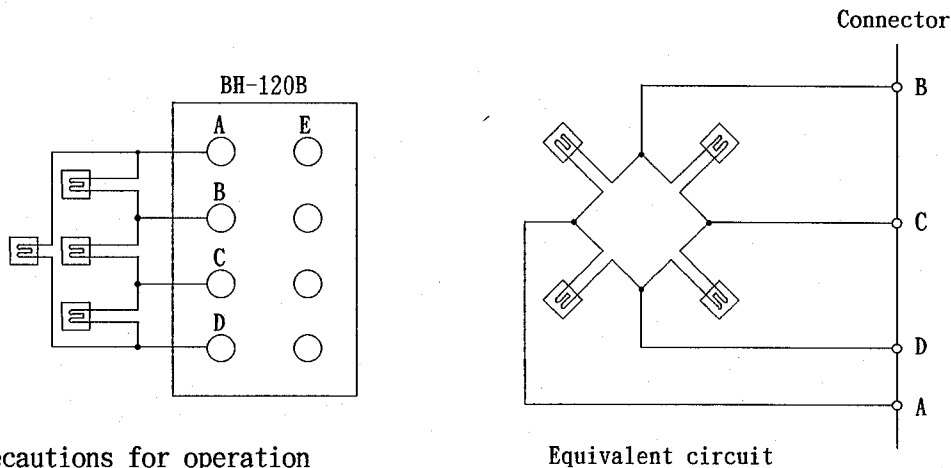

#### 6. Precautions for operation

- 1) Tighten the terminals fully when connections between lead wire and short-circuit with terminals are performed.

In case of application with soldered terminal, solder it securely.

Moreover, make use of the copper wire with the size of about 1mm or tinned wire, when short is required.

- 2) Use the shield wire as possible for the lead wire between strain gage and bridge box for preventing from external induction.

Be sure to connect the housing of shield wire with Ⓜ terminal.

- 3) Earth terminal (Ⓜ) is desired to be grounded, however, if some electric potential is existed at the object to be measured, grounding is not always required.

There may be cases of causing good effect when the earth terminal is connected with the object to be measured.

- 4) Be sure to use Minebea's standard cable (CAB-502), as for the cable between the strain instrument and bridge box.

- 5) When installing, select a location where water, oil, dust, organic gas and so on should not touch with the instrument directly.

## 7. Outline dimensions

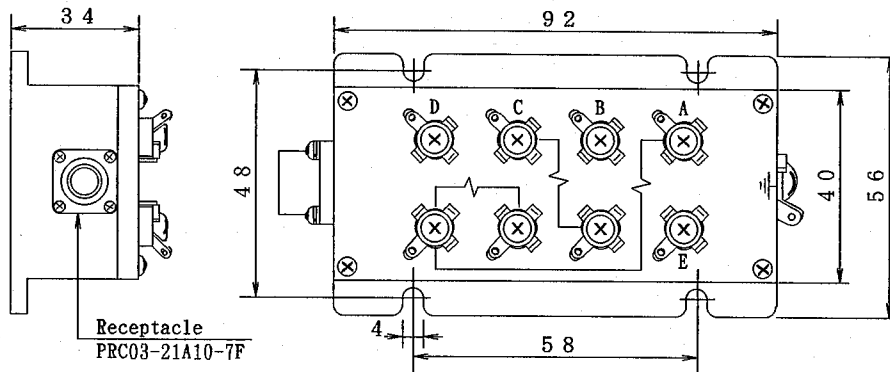

Unit : mm

- The contents of this manual may subject to change without notice.

HEAD QUARTER : **MINEBEA CO., LTD.**

4106-73 Miyota, Miyota-machi, Kitasakugun, Nagano-ken 389-0293, Japan

☎0267-32-2200 FAX.0267-31-1350

**Measuring Components Business Unit**

FUJISAWA PLANT 1-1-1, Katase, Fujisawa-shi Kanagawa-ken, 251-8531 Japan

☎0466-22-7151 FAX.0466-22-1701

KARUIZAWA PLANT 4106-73 Miyota, Miyota-machi, Kitasakugun, Nagano-ken 389-0293, Japan

☎0267-31-1309 FAX.0267-31-1350

HOME PAGE ADDRESS **<http://www.minebea-mcd.com>**