

■ Attention in installation

⚠ Matter of attention

Warning may cause injury or accident that may harm to the operator.
Don't do these things described here.

About carrying

- Please confirm there is not loosening in the guide plate fixation bolt when unit is transported.

This unit might decompose and accessories fall.

- Please never do its hanging with the cable of the load cell when this unit is transported.

The load cell might be disconnected, and this unit might fall.

About installing place

- Please work very carefully on the safety when you set up this unit.

- Please use the instrument where the temperature/humidity specifies with the range as follows

Environmental temperature: -10 °C to 70 °C

Environmental humidity :85 %RH or less (recommendation)

- Please install the bolt surely in consideration of the locking when you set up this unit.

When this is neglected, the specification of this unit might be damaged.

- Please do not weld the plate section of this unit directly with the structure (beam and bracket, etc.).

The specification of this unit might be damaged.

- Please protect the load cell cable with the piping material.

There might be caused the insufficient insulation resistance or disconnection due to the coating deterioration by the injury, the medicine, and washing.

- When you want to hold the tank for the purpose of level adjustment on the tank or exchanging load cells, occupy a space for jacking up between the bracket and the trestle of the tank.

- There is a possibility of damaging the load cell when measures are insufficient.

When making weld near the vicinity of load cells, weld it after removing the load cells .

In the case th

■ Revision history

Date	Instruction NO.	Content
Nov,2010	DWG NO.EN293-1025	First edition
Jan,2012	DWG NO.EN293-1025A	FN12-01002
Oct,2013	DWG NO.EN293-1025B	FN13-01071
May,2016	DWG.NO.EN293-1025C	KN16-0229

■ Name of each section

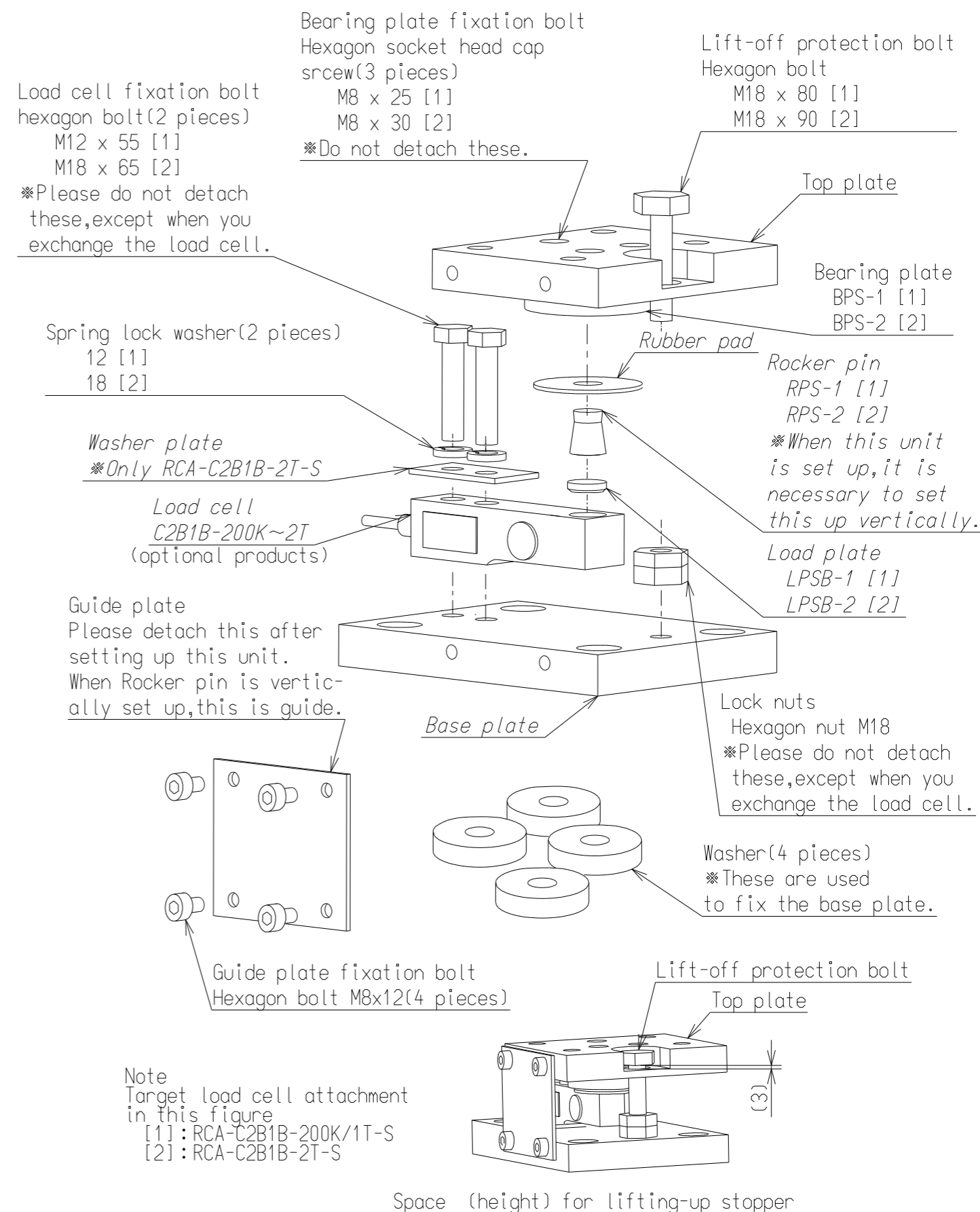

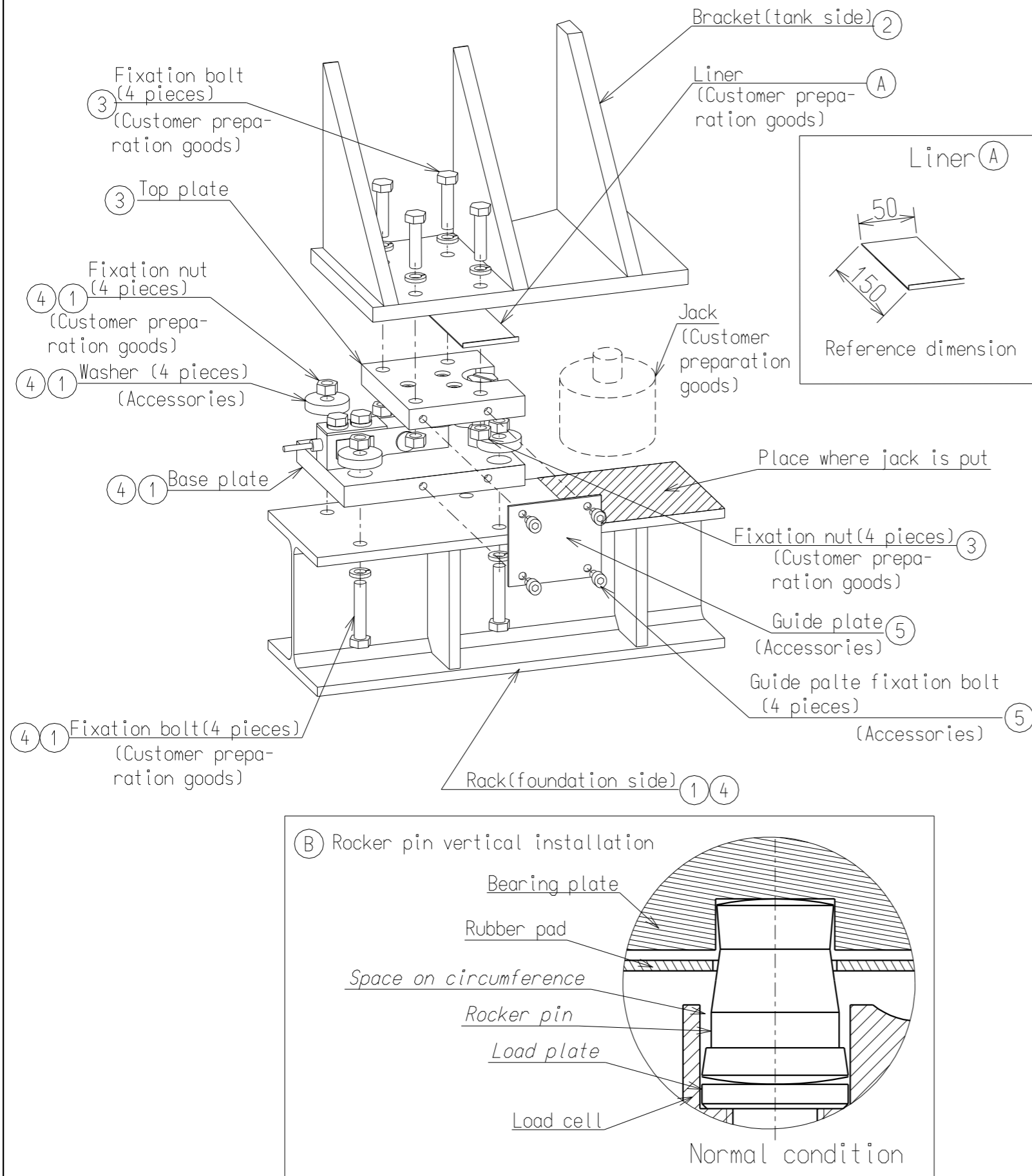

■ Example of installation procedure

- ① The base plate is temporarily fixed to the rack.
The horizontal on the rack is made within ± 0.3 degrees.
Be sure to use the washer.
- ② The tank is unloaded.
- ③ The top plate is fixed to the bracket.
- ④ The base plate is fixed to the rack.
- ⑤ The guide plate is removed.

■ Example of adjustment procedure

After this unit is set up, the following installation adjustments are done.
Ideal condition

- When the tare is loaded, set the difference within 30% (standard) against the even sharing of the output from each load cell.
However, when the center of gravity position shifts extremely from the support point center, it is not that.
 - When this unit is set up, rocker pin is made vertical.
- ① Method of adjusting level
- Do with the level adjustment?
It is to adjust the tare (tank mass) evenly by each load cell as allotted. You will prepare each of several liners (0.1, 0.2, 0.5, 1 mm).
 - Adjustment procedure
The tare allotment is confirmed.
The liner is placed between the load cell section with a low tare allotment. A fixed bolt on the bracket side is loosened.
The tank improves in the jack.
The liner is placed between the bracket and the top plate.
The tank is unloaded.
A fixed bolt on the bracket side is tightened.
- ② Rocker pin vertical installation
- Reason
The self-checking function might not work effectively when the installation of this unit has inclined.
 - Confirm method
The rubber putt is turned over.
It is confirmed whether the space (interval) between the spot facing hole of the load cell and the rocker pin are even in the circumference by watching.
 - Adjustment procedure
The tank is jacked just a little.
The rocker pin is vertically supported.
(However, be sure to do it with a metallic ruler etc. and not to do directly by the finger.)
The tank is