

Minebea

*Check-Rod Type Mounting Attachment
with Slide Stop Mechanism*

CCACC010-※※B※(S)

Instruction Manual

Forward

Thank you very much for your purchasing Minebea's Mounting attachment with slide stop mechanism CCACC010-※※B※(S). This manual explains operating method and important notices in the case of using CCACC010-※※B※(S).

Since misoperation might cause unexpected faulty condition, be sure to read this manual before use for the purpose of using this machine properly and safely.

Moreover, the end user should keep the manual at hand after reading it over.

Marks and arrangements used in this manual

The following marks are attached to the explanation on the matters that indicate “Don’t do this.”, “Take care.” and “For reference.”

Be sure to read these marks where these marks are attached.



Warning

Never do these things described here.
This is the warning that may cause injury or even to death to the operator.



Notice

This is the description when the operator might suffer harm during misoperation, and when only the material damage might be occurred.



Caution during operation and working.
Be sure to read the item to prevent from malfunction.

For safe operation

Be sure to read this manual before use.

1. Installation place



Notice

Use the instrument where the temperature and humidity specify within the range as follows:

- Environmental temperature : $-10\text{ }^{\circ}\text{C}$ to $50\text{ }^{\circ}\text{C}$
- Environmental humidity : 85 %RH or less (Excludes frozen.)



Warning

Never install the instrument on the places such as follows: It may cause unexpected faulty in the instrument.

① Location where installation is not allowed.

- Don't locate the instrument in direct and/or high temperature area.
- Avoid the location where corrosive gas and salty atmosphere may exist a lot.
- Don't install the instrument where there is rapid change of temperature and humidity.
- Don't install the instrument near the devices that become magnetized or generate an electromagnetic field.
- Avoid the location where influence of radioactivity or radiation may effect.
- Avoid the location where chemical reaction may take place such as in a laboratory or like that.

② When installing the instrument



Notice

When installing the instrument, be sure to follow the following items.

- To ensure the applied load fully, make design the strength of bracket and trestle where the mounting attachment with slide stop mechanism shall be installed.
- The bracket and trestle to install the mounting attachment with slide stop mechanism will be very important section to support load, so execution of works should be made carefully.
- The bracket and trestle to install the mounting attachment with slide stop mechanism should be constructed to be vertical to the direction of loading.
(For the horizontality of the trestle shall be within 1/2 "for the general application, and if you want to require high accuracy, make it within 1/4".)
- When you want to hold the tank for the purpose of level adjustment on the tank or exchanging load cells, occupy a space for jacking up between the bracket and the trestle of the tank.
- When installing the mounting attachment with slide stop mechanism in a pit, you should consider a measure such as a drain not to stagnate water.
- Please protect cover so that neither direct sunshine, nor wind, nor rain may strike directly to the mounting attachment with slide stop mechanism in outdoor. The cover might be detached when maintaining it, and please make the cover a structure that can be detached.
- We recommend that the height of installation of the mounting attachment with slide stop mechanism should be located near the center of gravity of the tank.
- We also recommend you to install stay rods together where there may have some vibrations due to mixers or so on.
- When installing the mounting attachment with slide stop mechanism, take care fully, because it

is constructed with the design of thermal expansion of a tank fully. The followings are the examples of directions of installation.

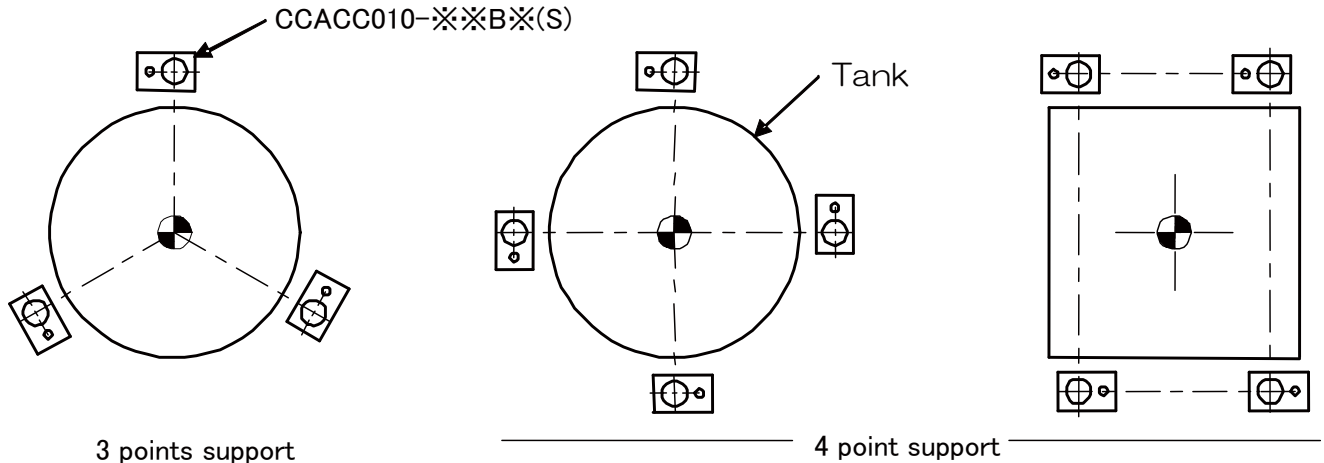

3 points support

4 point support

- In the case of installation, fasten the bolts tightly with looseness considered.
- Never weld the mounting attachment with slide stop mechanism to the construction (beam, bracket and so on) directly.
- It is not recommendable to weld in the condition of installing the load cell on the mounting attachment with slide stops mechanism as much as possible. If you really want to execute to weld, be sure to prepare for the earth wire near the welding point not to pass the welding current to the load cell. Moreover, remove the load cell cable from the amplifier for safety.
- Never cut off the load cell cable. If you cut off, there may have the possibility of deviation of calibration value.
- If you measure with touched condition of the top and bottom of mounting attachment with side stop mechanism, correct measurement shall not be obtained.

Be sure to check that the top and bottom of the mounting attachments with side stop mechanism are on the concentric arrangement, after installation has over.

- Install the lower base with the attached washer.

- Locate the load cell vertical position against the installation surface of mounting attachment with slide stop mechanism.
- A spot facing hole has prepared so that the load button of load cell can enter the bearing plate.

Be sure to insert the load button of load cell.

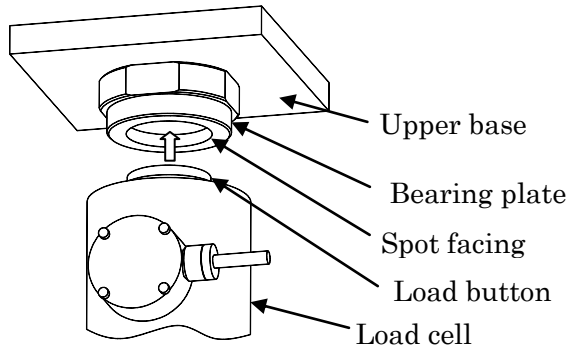

- The construction of bearing plate is the one to screw into the upper base. This is because the shim (prepared articles by customer) for level adjustment will be inserted between the upper plate and the bearing plate. Use the bearing plate with screwed condition fully. Never use it with the condition of having a space between the bearing plate and the upper base, or never use it with the bearing plate instead of a jack.

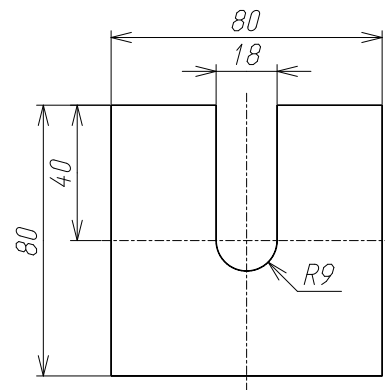
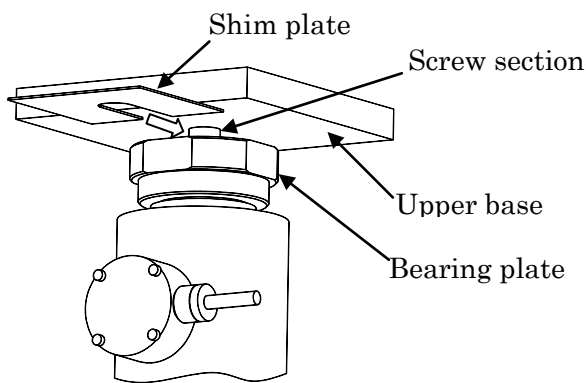

③ When delivering the instrument

Notice

When you deliver the instrument, take care of the following items.

- When you deliver the instrument, check that there' ll be no looseness at the fixing bolt on the side lock plate. If not, there may have the possibility of disassemble of the instrument or falling down the accessories might occur.
- Since the instrument is heavy enough, take care not to make burden on your body. So try to use a cart or other tools when you carry the instrument.
- Take care fully not to get hurt by falling down the instrument.
- Never carry the instrument by holding the cable of load cell.
There may have the possibility of cutting off the wire or dropping the instrument.

2. Notice in case of application

Notice

When you use the instrument, care should be taken fully on the following items.

- The dummy pipe is used for taking up space for load cell when the mounting attachment with slide stop mechanism is installed. So, after installation, be sure to exchange the genuine load cell.
- Don't apply the load on the load cell more than the rated capacity of load cell.
 $\text{Rated capacity} > \text{Tare weight} + \text{Weight of measuring object}$
- Don't apply impact load to the load cell.
- Don't throw something to the cable, nor pull it by force nor bend it.
- Never try to remodel, repair or take apart the mounting attachment with slide stop mechanism and load cell.
- Keep the manual for the instrument and some parts that have removed.
They will be required in the case of maintenance.

Record of revision

Date	Reference No.	Revised reason (Contents)
2008/09	DRW. NO.EN294-1365	First version
2008/10	DRW. NO.EN294-1365-A	FN08-01029 • The erratum is corrected.
2009/12	DRW. NO.EN294-1365-B	FN09-01032 • Changed Parts Number
2010/10	DRW. NO.EN294-1365-C	FN10-02140 • Minebea logo is changed.
2012/05	DRW. NO.EN294-1365-D	FN12-01052 • Minebea logo is changed.
2016/06	DRW. NO.EN294-1365-E	FN16-02057 • Delete 'Minebea Co., Ltd. Measuring Components Business Unit' from the front cover. FN10-02140-E • Minebea logo is changed.

Index

<i>FORWARD</i>	<i>I</i>
<i>MARKS AND ARRANGEMENTS USED IN THIS MANUAL</i>	<i>I</i>
<i>FOR SAFE OPERATION</i>	<i>II</i>
1. INSTALLATION PLACE.....	<i>II</i>
2. NOTICE IN CASE OF APPLICATION.....	<i>V</i>
<i>RECORD OF REVISION</i>	<i>VI</i>
<i>1. NAME OF EACH PART</i>	<i>1</i>
1-1. MOUNTING ATTACHMENT WITH SLIDE STOP MECHANISM AND LOAD CELL	<i>1</i>
<i>2. EXAMPLE OF INSTALLATION PROCEDURE</i>	<i>2</i>
2-1. INSTALLATION OF THE MOUNTING ATTACHMENT WITH SLIDE STOP MECHANISM	<i>2</i>
2-2. INSTALLATION OF LOAD CELL	<i>3</i>
2-3. INSTALL THE LIFT-OFF PROTECTION FITTING.....	<i>4</i>
2-4. FINAL CHECK.....	<i>6</i>
<i>3. SPECIFICATIONS</i>	<i>7</i>
3-1. CCACC010-3B※(S).....	<i>7</i>
3-2. CCACC010-6B※(S).....	<i>7</i>
3-3. CCACC010-12B※(S)	<i>7</i>
3-4. CCACC010-30B※(S)	<i>7</i>
3-5. ACCESSORIES	<i>7</i>
<i>4. WARRANTY</i>	<i>8</i>
4-1. WARRANTY	<i>8</i>
4-2. REPAIR	<i>8</i>

1. Name of each part

1-1. Mounting attachment with slide stop mechanism and load cell

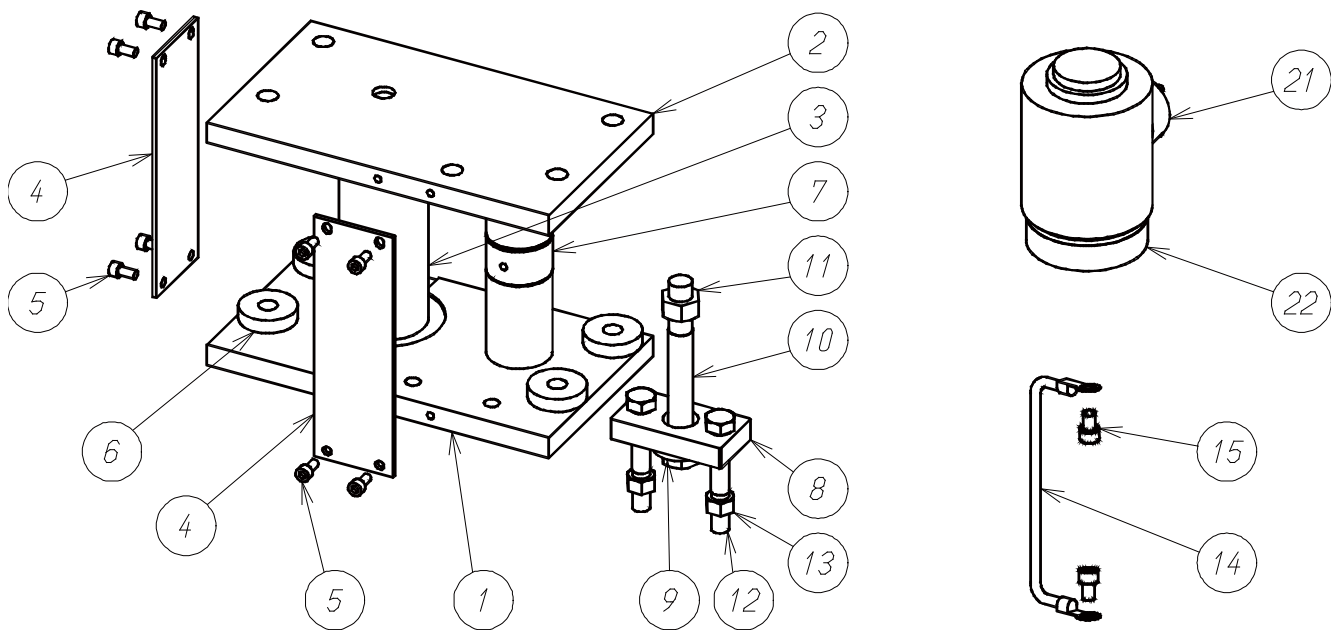

Fig.1

No.	Description	Quantity
1	Lower base	1
2	Upper base	1
3	Dummy pipe	1
4	Side rock plate	2
5	Fixing bolt for side rock plate (M6) (for CCACC010-30B※(S) : M8)	8
6	Washer	4
7	Ring for stopper	1
8	Plate for stopper	1
9	Color	1
10	Lift off protection bolt A (width across flat for CCACC010-3B※(S) : 24mm, for CCACC010-6B※(S) : 30mm, for CCACC010-12B※(S) : 46 mm, for CCACC010-30B※(S) : 65 mm)	1
11	Rock nut for lift-off protection bolt (Width across flat for CCACC010-3B※(S) : 24mm, for CCACC010-6B※(S) : 30mm, for CCACC010-12B※(S) : 46 mm, for CCACC010-30B※(S) : 65 mm)	1
12	Bolt B for lift-off protection (Width across flat for CCACC010-3B※(S) : 18mm, for CCACC010-6B※(S) : 24mm, CCACC010-12B※(S) : 30 mm, for CCACC010-30B※(S) : 46 mm)	2
13	Rock nut B for lift-off protection bolt (Width across flat for CCACC010-3B※(S) : 18 mm, for CCACC010-6B※(S) : 24mm, for CCACC010-12B※(S) : 30 mm, for CCACC010-30B※(S) : 46 mm)	2
14	Earth cable	1
15	Bolt for installing earth cable.	2
	Options	
21	Load cell (CC010)	1
22	Bottom plate (accessory of CC010)	1

2. Example of installation procedure

2-1. Installation of the mounting attachment with slide stop mechanism

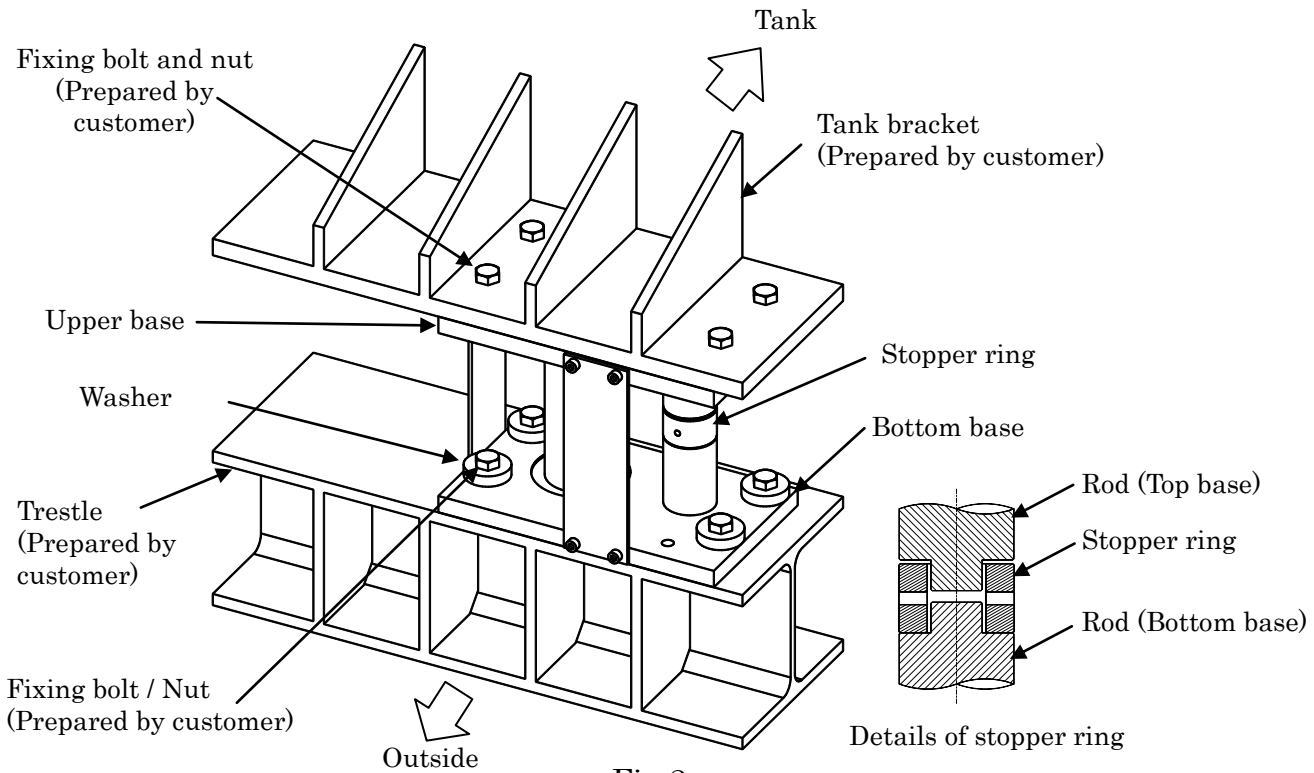

Fig.2

- ① Fix the lower base to the trestle temporarily.
At this time, fix by using the attached washer.
- ② Lower the tank
(Lower the tank slowly so that the holes of bracket adjust to the installation holes on the upper base of the mounting attachment with slide stop mechanism)

Notice

Make it slowly not to apply any impact

Notice

Take care fully not to catch your finer(s) or hand(s).

- ③ Fix the upper base to the bracket
- ④ Move the lower base so that the rod expands from the upper base and the rod expands from the lower base are set on the same axis by looking through the hold of the stopper ring.
- ⑤ Fix the lower base to the bracket.

Table of fixing bolt and nut

P/No.	Recommended installation screw	Number of required quantities/set
CCACC010-3B※(S)	M12	8 pieces
CCACC010-6B※(S)	M16	8 pieces
CCACC010-12B※(S)	M20	8 pieces
CCACC010-30B※(S)	M30	8 pieces

2-2. Installation of load cell

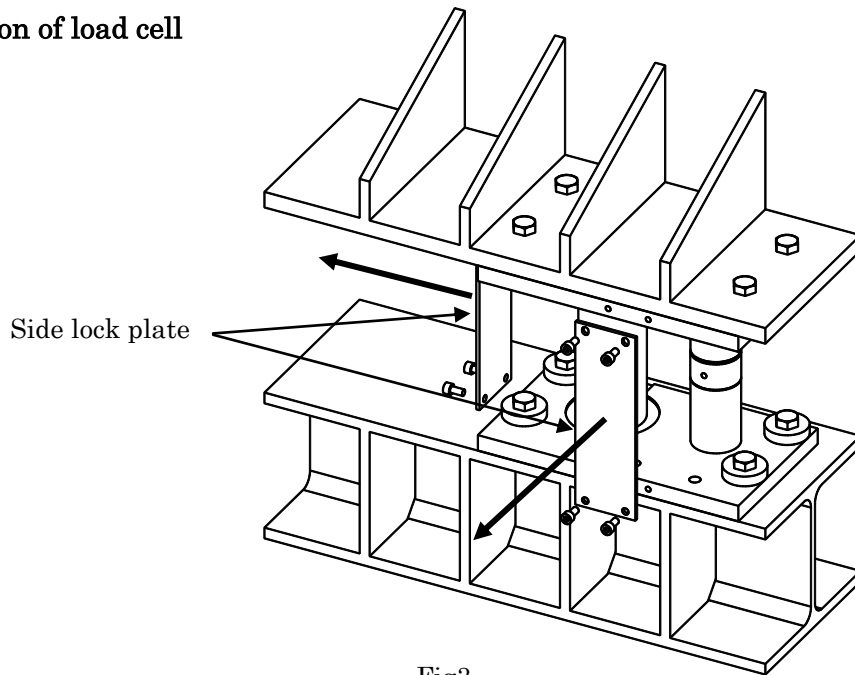

Fig3

- ① Remove the side lock plate (2 points)

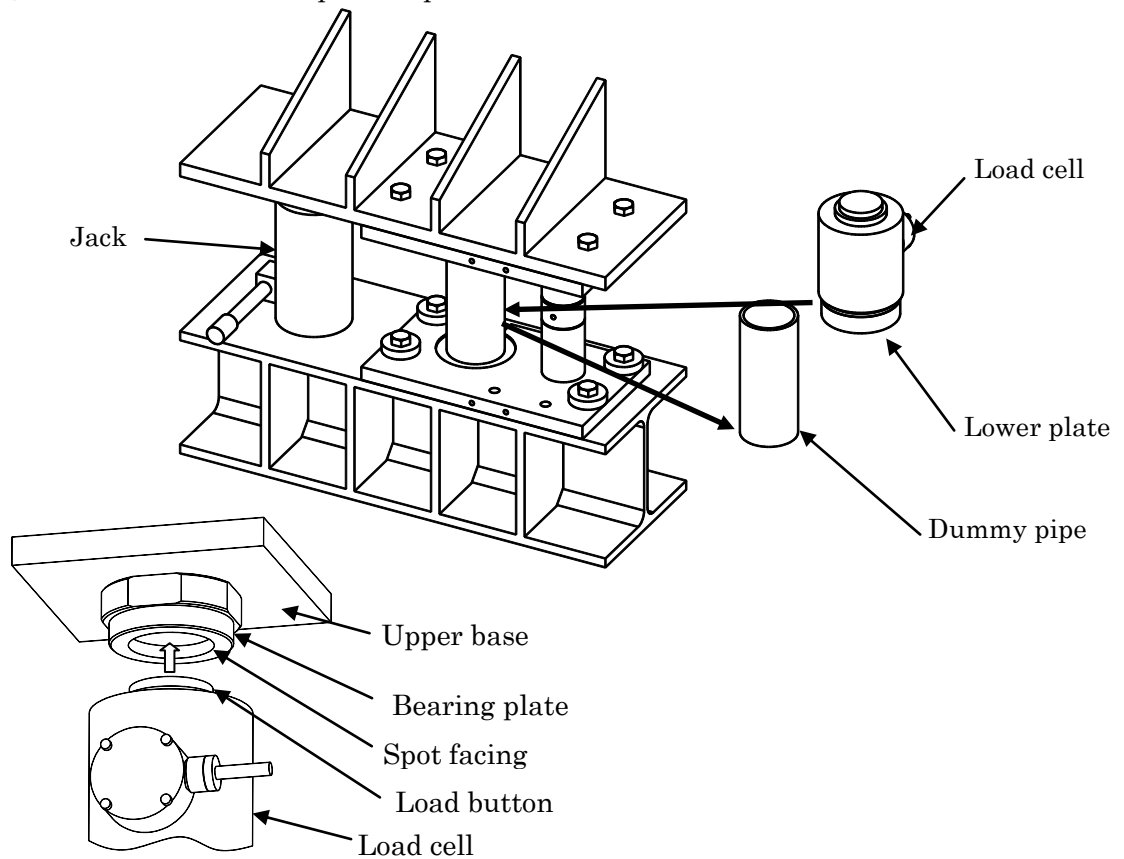

Fig4

- ② Remove the dummy pipe with the jack by holding up the tank about 11 mm.
③ Install the load cell with the lower plate together to the position where the dummy pipe was existed.
At the same time, be sure to insert the load button of load cell into the spot facing of the bearing plate.

- ④ Lower the tank slowly
 At this time, check that the load cell stands vertically.
 If not vertical, lift and adjust the tank again for the load cell to stand vertically.

! Notice

Make it slowly not to apply any impact..
 These may have the case of possibility of destruction due to overload on the load cell

! Notice

Take care fully not to catch your finger(s) or hand(s).

2-3. Install the lift-off protection fitting

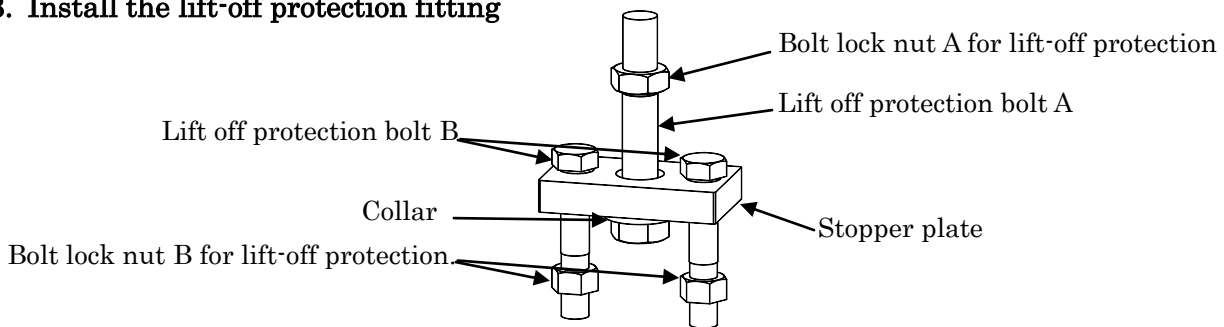

Fig.5

- ① Install the Lift-off protection metals attached to the same condition as shown in Fig.5.
 In the case of CCACC010-30B※(S), a lift-off protection bolt A and a lock nut lift-off prevention A, and a stopper plate and a collar are installed condition.

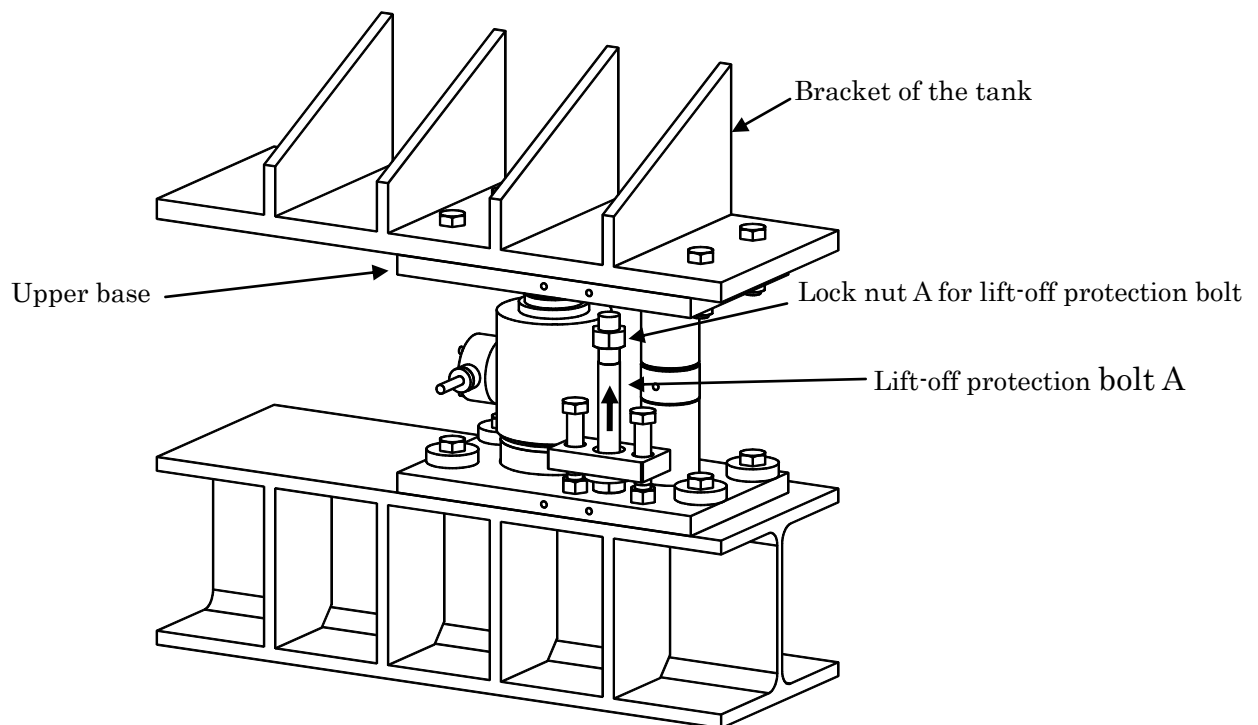

Fig.6

- ② Screw in the lift-off protection fitting bolt A (2 pieces) to the lower base

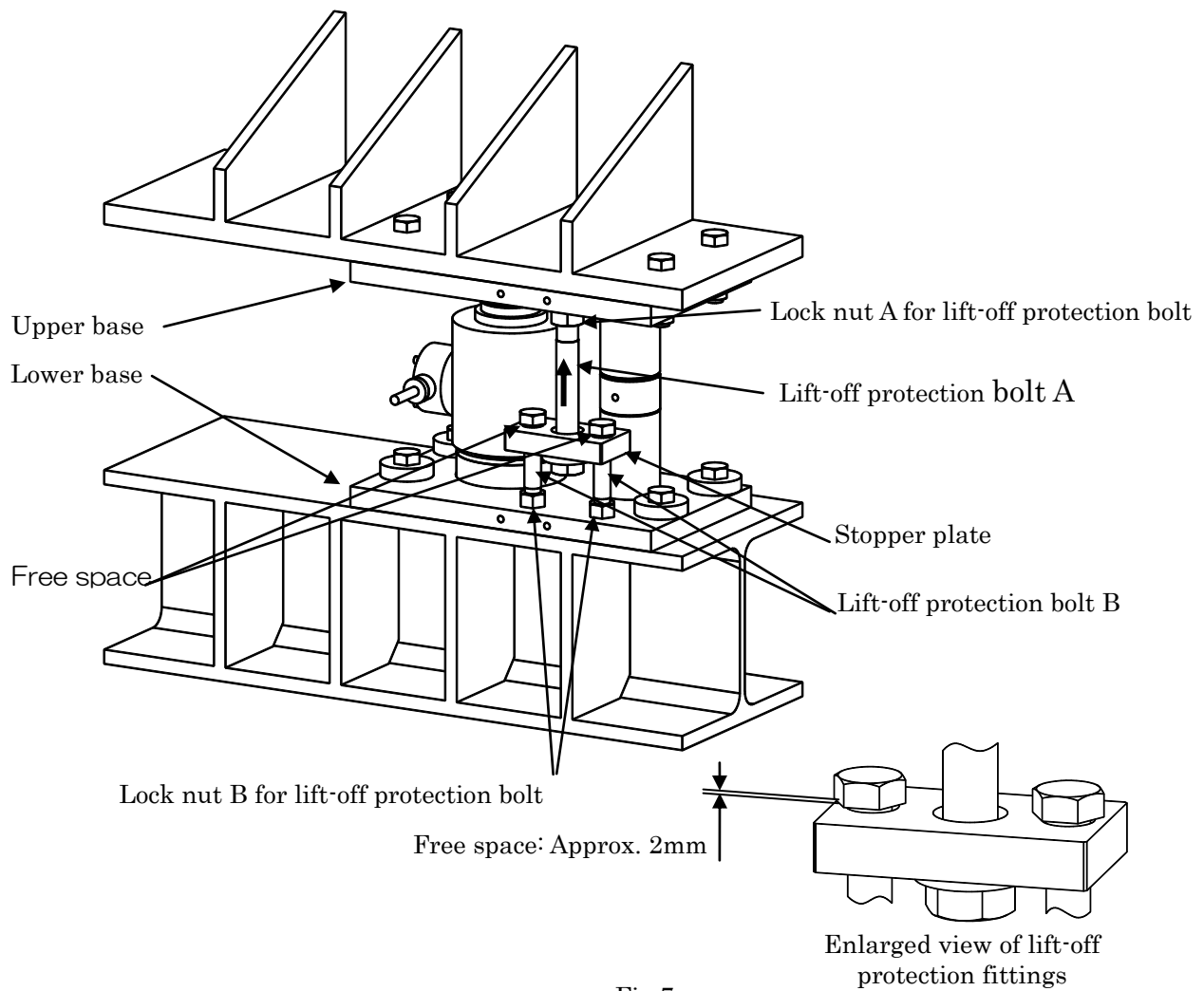

Fig.7

- ③ Screw in the lift-off protection bolt B (2 pieces) to the lower base.
In this case, screw in until the point of the bolt touches to the rack.
- ④ Lock the lift-off protection bolt by lock nut B.
- ⑤ Screw in the lift-off protection bolt A into the upper base.
At this time, please keep the space of approx. 2 mm between the stopper plate and the lift-off protection bolt B.
- ⑥ Lock the bolt by lock nut A of the lift-off protection bolt.

2-4. Final check

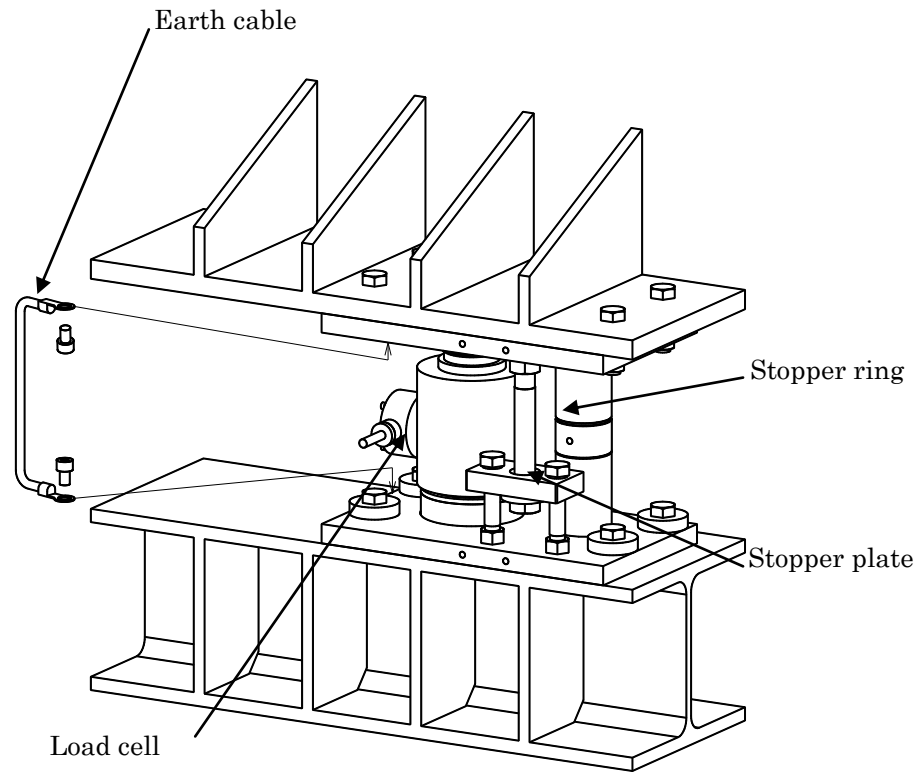

Fig.8

- ① Confirm the rod expands from the upper base and the rod expands from the lower base becomes on the same axis by looking through the hole of the stopper ring.
If the upper/lower rod is not set on the same axis, move the lower base according to the procedure of paragraph 2-1.④~⑤.
- ② Confirm the load cell is set in the vertical.
If load cell is not in vertical, please set in vertical according to the procedure of paragraph 2-2 ④.
- ③ Confirm the stopper plate is movable.
If the stopper plate is not movable, adjust it according to the procedure of 2-3 ④~⑤.
- ④ After completing all, install the earth cable between the upper and lower base plate.

3. Specifications

3-1. CCACC010-3B※(S)

Allowable horizontal load		$\pm 29.42 \text{ kN}$ { $\pm 3 \text{ tf}$ }
Allowable horizontal moving length		$\pm 3 \text{ mm}$
Allowable lifting load		29.42 kN { 3 tf }
Material	Steel	SS400 or equivalent
	Stainless (S)	SUS304 or equivalent
Weight		Approx. 15 kg

3-2. CCACC010-6B※(S)

Allowable horizontal load		$\pm 58.84 \text{ kN}$ { $\pm 6 \text{ tf}$ }
Allowable horizontal moving length		$\pm 3 \text{ mm}$
Allowable lifting load		58.84 kN { 6 tf }
Material	Steel	SS400 or equivalent
	Stainless (S)	SUS304 or equivalent
Weight		Approx. 20 kg

3-3. CCACC010-12B※(S)

Allowable horizontal load		$\pm 117.7 \text{ kN}$ { $\pm 12 \text{ tf}$ }
Allowable horizontal moving length		$\pm 3 \text{ mm}$
Allowable lifting load		117.7 kN { 12 tf }
Material	Steel	SS400 or equivalent
	Stainless (S)	SUS304 or equivalent
Weight		Approx. 29 kg

3-4. CCACC010-30B※(S)

Allowable horizontal load		$\pm 294.2 \text{ kN}$ { $\pm 30 \text{ tf}$ }
Allowable horizontal moving length		$\pm 3 \text{ mm}$
Allowable lifting load		294.2 kN { 30 tf }
Material	Steel	SS400 or equivalent
	Stainless (S)	SUS304 or equivalent
Weight		Approx. 55 kg

3-5. Accessories

Instruction manual		1 piece
Side lock plate		2 sheets (Shipped it while mounted in the device.)
Hexagon socket head cap screw (M6×L12) (30T/50T 又は M8×L16)		8 pieces (bolt for mounting the side lock plate.)
Dummy pipe		1 piece (Shipped it while mounted in the device.)
Lift-off protection fitting		1 set (Shipped as an accessory of the device)
Earth cable		1 piece (with bolt)

3-6. Model detail

CCACC010-~~XXXX~~B~~XXXX~~(S)
 Allowable horizontal load Loadcell Capacity

	1	2	3	4
3	500K/1T	2T/3T	5T/30T	50T
6	500K/1T	2T/3T	5T/30T	50T
12	500K/1T	2T/3T	5T/30T	50T
30	500K/1T	2T/3T	5T/30T	50T

Note: Depending on the capacity of load cell applied, the corresponding form shall differ.
 When you request the installing metals, specify the capacity of load cell (P/N) together with them.

4. Warranty

4-1. Warranty

- The instrument is covered by a warranty for a period of one year from the date of delivery.
- When you want to repair the instrument or request after-service, contact Minebea’s sales office or sales agency from which you have purchased.

4-2. Repair

Before asking repairs, please make checks once again that the installation, setting and adjustment for the instrument has finished precisely.
 After that still there may be found some defects in the instrument, please contact Minebea’s sales office or sales agency from which you purchased.

●The contents of this manual may subject to change without notice.

HEAD QUARTER: **MINEBEA CO., LTD.**

4106-73 Miyota, Miyota-machi, Kitasaku gun, Nagano-ken 389-0293 Japan
Tel: +81-267-32-2200 Fax: +81-267-31-1350

Sensing Device Product Sales Management:

1-1-1, Katase, Fujisawa-shi, Kanagawa-ken, 251-8531 Japan
Tel: +81-466-23-2681 Fax: +81-466-22-7191

Sensing Device Business Unit

FUJISAWA PLANT 1-1-1, Katase, Fujisawa-shi, Kanagawa-ken, 251-8531 Japan
Tel: +81-466-22-7151 Fax: +81-466-22-1701

KARUIZAWA PLANT 4106-73 Miyota, Miyota-machi, Kitasaku gun, Nagano-ken 389-0293 Japan
Tel: +81-267-31-1309 Fax: +81-267-31-1353

HOME PAGE ADDRESS <http://www.minebea-mcd.com>