

Minebea

MINEBEA Co., Ltd.

INSTRUCTION MANUAL

CC-Link

Digital indicator with CC-Link interface

CSD-891B-73

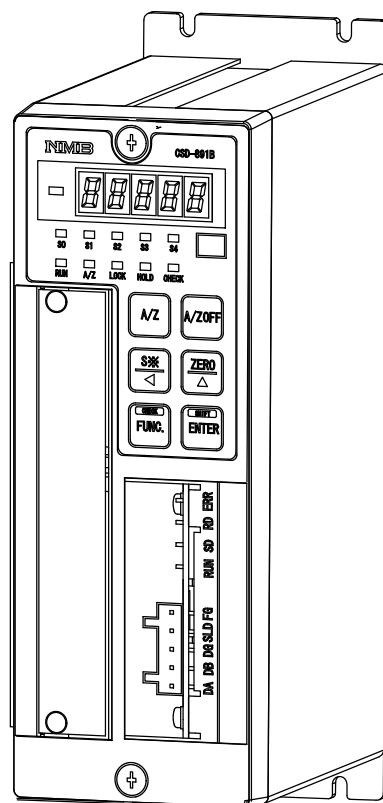

Note : Please read this Instruction Manual carefully before use.
Be sure to follow the items that require attention described in the manual.
Keep the manual at hand so that you can pick it up and read it as soon as
necessity requires.

Forwards

Thank you very much for your purchasing Minebea's Digital Indicator with CC-Link interface CSD-891B-73. This manual explains installation procedures and connecting method and also operating method for the Digital Indicator with CC-Link interface CSD-891B-73. When you will use this instrument as the specification with CC-Link interface, make use of it properly after reading through the manual carefully.

Be sure to deliver the manual to the end user. Moreover, the end user should keep the manual at hand after reading it over.

This manual is intended for the technical experts to read. When you read this instruction manual, the program basic knowledge of a Mitsubishi general-purpose sequencer and the basic knowledge of CC-Link interface are needed.

CC–Link is an abbreviation of “Control & Communication Link”

The contents of the manual may subject to change for improvement without notice.

Marks and arrangements used in this manual

The following marks are attached to the explanation on the matters that indicate “Don’t do this.”, “Take care.” and “For reference”.

Be sure to read these items where these marks are attached.



Warning

Warning may cause injury or accident that may harm to the operator.
Don’t do these things described here.



Caution during operation and working.

Be sure to read the item to prevent malfunction.

About the view of this book

In this instruction manual, the connection method and use of the CC–Link interface specification of the option for CSD–891B are explained. Please see the CSD–891B instruction manual about other main body functions and a basic method of handling and notes.

- CSD–891B instruction manual(DRW NO.294–1143*)

Moreover, please refer to the instruction manual on sequencer and sequencer side CC–Link interface for the sequencer program and CC–Link.

History of revision

Date	Instruction Manual No.	Details of revised point
Mar. 2002	DRW. NO. EN294-1146	First version CSD-891B main body Ver.1.300 or later CC-Link interface CARD Ver.01 or later
Jun. 2002	DRW. NO. EN294-1146-A	Due to ECN NO.FN02-02066 - Additional - 4-3. Add "Setting of numeric expression of minus" 6. Add "Numeric representation table of remote register" 6-1. Add the followings to the remark column of station No.1. in the table. "OL display : Set 99999" " - OL display : Set - 99999" 6-2. (1) Add the updating condition. Add the flag reset condition.
Oct. 2010	DRW. NO. EN294-1146-B	Due to ECN NO.FN10-02140 - Change - Minebea logo is changed.
Jan. 2011	DRW. NO. EN294-1146-C	Due to ECN NO.FN04-02152A Due to ECN NO.FN10-02013B CSD-891B main body : Ver.1.800 or later CC-Link interface CARD : Ver.04 or later - Additional - 3-1. Add the wiring diagram of the accessory plug. 4-1. Add the warning above about setting of the station. 4-1. Add "Setting of the station(Function F-84)" 5. Add the table of "2 occupied stations" and "1 occupied stations" 7-4. Add "Error condition/Reset request flag" 6-1.(2) Add "Refer to below table of error assistance code." 6-1.(2) Add the mapping table of error code and error assistance code. - Change - Change the contents number. Change "4 occupied stations" to "1,2 and 4 occupied stations" Change the item No. Change "4-2." to "4-3.",and "4-3." to "4-4." 4-2. Change some sentences. 6-2.(2) Change "Master This instrument" to "This instrument Master" 6-2.(2) Change "- request flag" to "- complete flag" Change "error reset request flag" to "error condition flag"

CONTENTS

Forwards	
Marks and arrangements used in this manual	
About the view of this book	
History of revision	
1. General	1
1-1. Features	1
2. Name and function of each point	2
2-1. Front panel	2
3. Connecting method	3
3-1. Connector pin configuration for communication	3
3-2. Connection	3
4. Setting by function mode	4
4-1. Setting of the stations(Function F-84)	4
4-2. Setting of the stations(Function F-85)	4
4-3. Setting of baud rate(F-86)	4
4-4. Setting of numeric expression of minus(F-87)	5
5. Address	6
6. Address map	7
6-1. Data zone	7
6-2. Relay zone	12
7. Operation method	20
7-1. Writing the set value (Special data area)	20
7-2. Writing/Reading by general command	21
7-3. Shift to status where it is possible to communicate	23
7-4. Error condition/Reset requesting flag	23
7-5. CPU normal operation signal	24
8. Specifications of interface	25

1. General

This unit is a remote device station of CC-Link Ver.1.10.

This unit can be connected with the mastering station of CC-Link Ver.1.10.

1-1. Features

Main features for CSD-891B-73 are as follows :

- (1) Because this unit can be controlled by using remote I/O and a remote register of the sequencer, the program volume of the sequencer can be reduced.
- (2) Wiring with the sequencer can be reduced.

2. Name and function of each point

2-1. Front panel

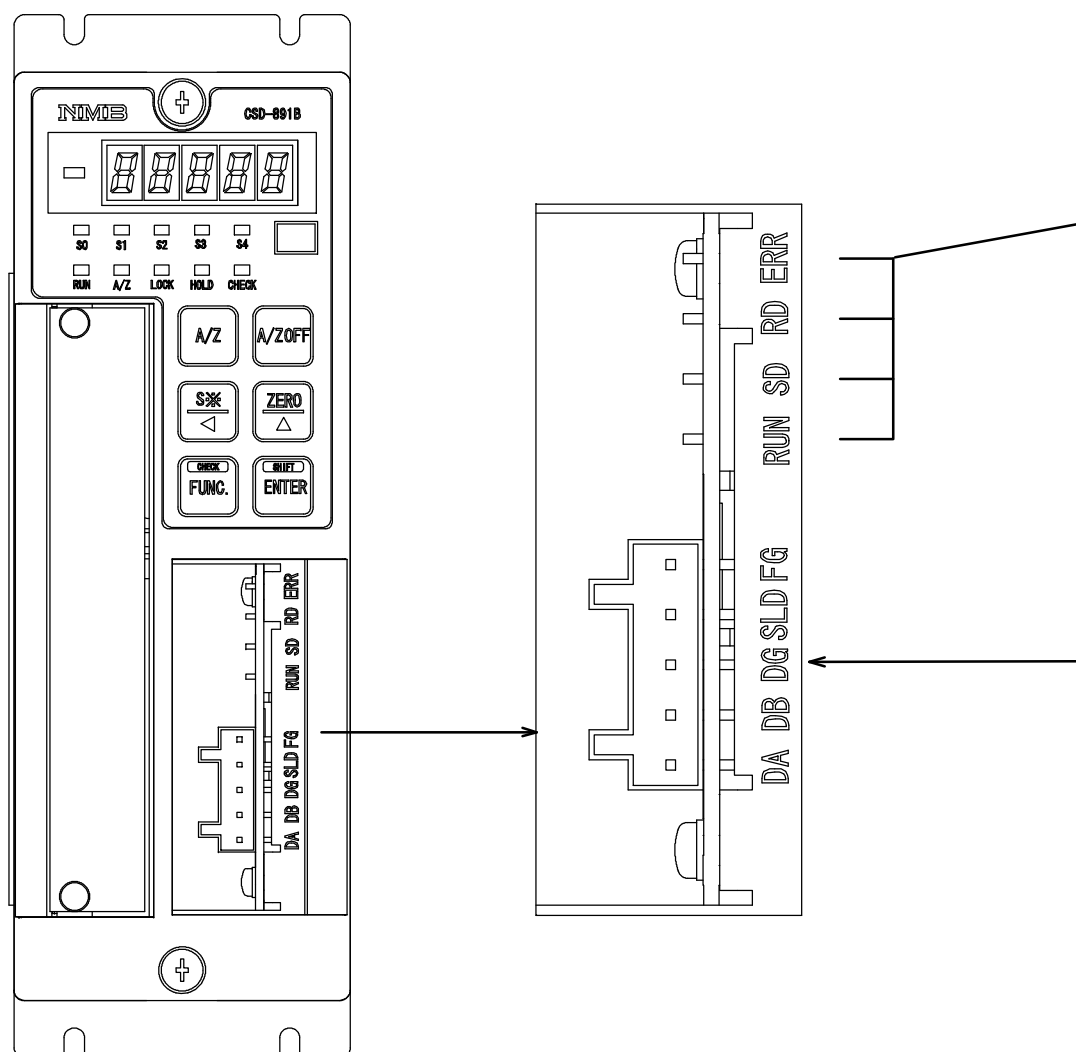

① Connector for communication

Connector type terminal block for CC-Link interface.

② Status LED

The communication status is expressed with four LED.

LED Name	Light on	Light off	Light on/off
RUN	• Normal	• In the reset • unavailable to communication	-
SD	• Sending	-	-
RD	• Receiving	-	-
ERR	• Abnormal setting • CRC error occurs. • Trouble	• Normal	• When setting changes

3. Connecting method

3-1. Connector pin configuration for communication

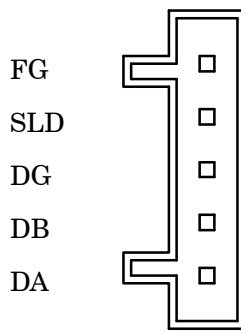

DA	Signal cable DA side
DB	Signal cable DB side
DG	Signal cable ground
SLD	Shield
FG	Frame ground

Suitable plug : 721-105/037-000 (WAGO) to be attached.



The internal circuit and photo coupler are insulated.

“SLD” and “FG” are connected in the instrument.

Please connect wires according to the following method.

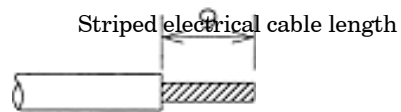
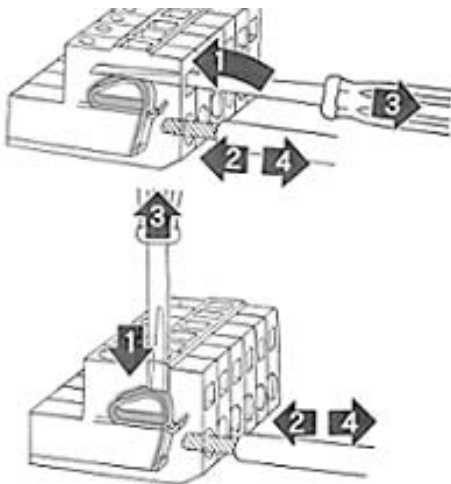

- Put in the driver minus type.
- Insert the electrical cable.
- Pull out the driver minus type.
- Confrim wire connection by a few tension.

3-2. Connection

Please follow the instruction of connecting wires on the sequencer instruction manual about connecting wires.

4. Setting by function mode

Please set the following items in the function mode when you use CC-Link interface.

Please refer to clause 8-1 of the CSD-891B instruction manual for "Method of setting the function".

4-1. Setting of the stations.(Function F-84)

The number of occupied stations of CC-Link is set. The range which can be set is from No.0 to No.2.

F-84	Setting of the stations	0 : 1 stations occupied 1 : 2 stations occupied 2 : 4 stations occupied
------	-------------------------	---



Setting changes for occupied stations No is corresponding to this software after ROM Ver.1.800 and after CC-Link I/F CARD software ROM Ver.04.

Before ROM Ver.1.700 and Ver.03 is 4 station occupied station No.

4-2. Setting of the stations(Function F-85)

The station of CC-Link is set. The range which can be set is "01-64". The occupied station of this unit is 1,2 and 4 points.

When 1 stations are occupied, the range which can be set is "01-64".

When 2 stations are occupied, the range which can be set is "01-63".

When 4 stations are occupied, the range which can be set is "01-61".

For example, when the station number is assumed to 01, No. 01 to No. 04 stations are occupied.

Therefore, the station number must not overlap as shown in the following figure.

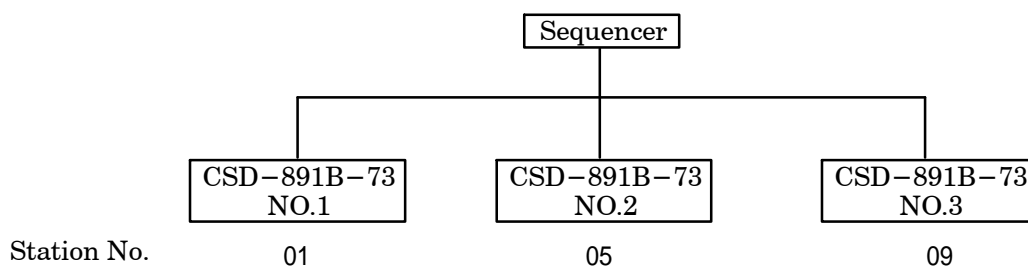

F-85	Set of station number	When it is 1 occupied station: selectable from station No 1 to 64. When it is 2 occupied station: selectable from station No 1 to 63. When it is 4 occupied station: selectable from station No 1 to 61.
------	-----------------------	--

4-3. Setting of baud rate(F-86)

The transmission rate of CC-Link is set. The range which can be set is from No.0 to No.4.

F-86	Setting of baud rate	0 : 156 kbps, 1 : 625 kbps, 2 : 2.5 Mbps 3 : 5 Mbps, 4 : 10 Mbps
------	----------------------	---

4-4. Setting of numeric expression of minus(F-87)

The expression when the value of remote register is “Negative (minus)” is set. The range which can be set is “0” or “1”.

F-87	Setting of load value expression of minus	0 : Expression of standard binary 1 : The left end digit “8” fixation at ”Negative (minus)”
------	---	--

Load value	F-87	Lower 16 bit	Upper 16 bit
- 1	0	FFFFH	FFFFH
	1	8000H	0001H
- 10	0	FFFFH	FFF6H
	1	8000H	000AH
- 99999	0	FFFEH	7961H
	1	8001H	869FH



Setting this function becomes effective at power supply ON.
Please turn off the power supply after the changes.

5. Address

A remote I/O(RX/R_Y : Bit handling register) and a remote register(RW_w/RW_r : Word handling register) secures the zone in the master station depends on the occupied station number. As shown in the table below in case of this unit.

Type		Occupied station number			Remarks
		Occupies 4 stations	Occupies 2 stations	Occupies 1 station	
Remote input		128 points	64 points	32 points	I/O for each 16 points is occupied as a system area.
Remote output		128 points	64 points	32 points	
Remote register	Master Remote	16 points	8 points	4 points	
	Remote Master	16 points	8 points	4 points	

The address number of the remote station allocated to the mastering station is as shown in the table below.

Station No.	Remote input	Remote output	Remote register		Remarks
			Master Remote	Remote Master	
0	-	-	-	-	Specify the master station
1	RX0000	RY0000	RW _w 0000	RW _r 0000	
	00E0	0160	01E0	02E0	
2	RX0020	RY0020	RW _w 0004	RW _r 0004	
	00E2	0162	01E4	02E4	
3	RX0040	RY0040	RW _w 0008	RW _r 0008	
	00E4	0164	01E8	02E8	
~					
10	RX0120	RY0120	RW _w 0024	RW _r 0024	
	00F2	0172	0204	0304	
~					
64	RX07E0	RY07E0	RW _w 00FC	RW _r 00FC	
	015E	01DE	02DC	03DC	

6. Address map



In this paragraph, the address of “Remote input”, “Remote output”, and “Remote register” when the station Number of 1 is set. Please note that the address is different when you set the station number except No.1.

6-1. Data zone

(1) Remote register(Master This instrument)

Occupies 4 stations					
Station	Buffer Address	Register Master CSD-891B	Contents		Remarks
1	01E0	RWw0000	S0 set value	32 bit	Special data area
	01E1	RWw0001			
	01E2	RWw0002	S1 set value	32 bit	
	01E3	RWw0003			
2	01E4	RWw0004	S2 set value	32 bit	
	01E5	RWw0005			
	01E6	RWw0006	S3 set value	32 bit	
	01E7	RWw0007			
3	01E8	RWw0008	S4 set value	32 bit	
	01E9	RWw0009			
	01EA	RWw000A	32 bit		
	01EB	RWw000B			
4	01EC	RWw000C	General data area	32 bit	
	01ED	RWw000D			
	01EE	RWw000E	Command No.(Return) 8 bit		
	01EF	RWw000F	Operating mode(Return) 8 bit		

Occupies 2 stations					
Station	Buffer Address	Register Master CSD-891B	Contents		Remarks
1	01E0	RWw0000	S0 set value	32 bit	Special data area
	01E1	RWw0001			
	01E2	RWw0002	S1 set value	32 bit	
	01E3	RWw0003			
2	01E4	RWw0004	General data area 32 bit		
	01E5	RWw0005			
	01E6	RWw0006	Command No.(Return) 8 bit		
	01E7	RWw0007	Operating mode(Return) 8 bit		

Occupies 1 station				
Station	Buffer Address	Register Master CSD-891B	Contents	Remarks
1	01E0	RWw0000	Unused 32 bit	
	01E1	RWw0001		
	01E2	RWw0002		
	01E3	RWw0003		

Remote register(Master station This instrument)

① Special data area(4 stations,2 stations)

When the set value is registered by using the set value writing request (request 1), the set value is set in each area.

Details of each set value are shown as follows;

set value from S0 to S4

Execute the setting of the comparative data.

Data type : 32 bit binary with sign

Setting range : - 99 999 ~ 99 999

② General data area(4 stations,2 stations)

When the command order is executed by using the general command request (request 2), the set value or the operating order code is set in this area.

Data type : 32 bit binary with sign

Range of setting value : - 99 999 ~ 99 999

③ Command No.(4 stations,2 stations)

When the command order is executed by using the general command request (request 2), the command No. is set in this area.

The content of the general data area is set depending on the command set in this command No.

Data type : 8 bit binary

Range of setting value : 0 ~ 255

④ Operation mode(4 stations,2 stations)

When the operation mode is a changeover and is gotten by using the operation mode changeover request (request 3), the mode number is set in this area. Mode only 0 corresponds in the current state, and write 0 here, please.

Data type : 8 bit binary

Range of setting value : 0 ~ 255 (However, only 0 corresponds in the current status.)

⑤ Commands list(4 stations,2 stations)

When the command order is executed by using the general command request (request 2), the value set in command No. and the general data area is indicated as follows;

Writing the set value and operation request (Writing/Reading out selection=Writing OFF)

Setting value or command request	Command No. (RWw000E)	General data area (RWw000C ~ RWw000D)
S0	10	- 99 999 ~ 99 999
S1	11	- 99 999 ~ 99 999
S2	12	- 99 999 ~ 99 999
S3	13	- 99 999 ~ 99 999
S4	14	- 99 999 ~ 99 999
Tare weight cancellation ON(A/Z ON)	0	14
Tare weight cancellation OFF(A/Z OFF)		15
Zero set ON(ZERO)		16
Reset of sequence error		36

Reading out the setting value(Selection of writing/Reading out = Reading out[ON])

Setting value or Command request	Command No. (RWw000E)	General data area (RWw000C ~ RWw000D)
S0	10	- 99 999 ~ 99 999
S1	11	- 99 999 ~ 99 999
S2	12	- 99 999 ~ 99 999
S3	13	- 99 999 ~ 99 999
S4	14	- 99 999 ~ 99 999



Numeric representation of a remote register is as shown in the table below as a rule. However, the negative numeric expression is different according to setting F-87. Please refer to the paragraph 4-4.

Decimal number	16 bit data	32 bit data	
		Upper position	Lower position
0	0000H	0000H	0000H
1	0001H	0000H	0001H
10	000AH	0000H	000AH

(2) Remote register(Instrument Master)

Occupies 4 stations				
Station	Buffer Address	Register Master Instrument	Contents	Remarks
1	02E0	RWr0000	Net weight value	OL display : Set 99999 - OL display : Set - 99999
	02E1	RWr0001		
	02E2	RWr0002	Gross weight value	
	02E3	RWr0003		
2	02E4	RWr0004	Undefined	
	02E5	RWr0005		
	02E6	RWr0006	Error code	
	02E7	RWr0007	Error assistance code	
3	02E8	RWr0008	Undefined	
	02E9	RWr0009		
	02EA	RWr000A		
	02EB	RWr000B		
4	02EC	RWr000C	General data area	
	02ED	RWr000D		
	02EE	RWr000E	Command No.(Response)	
	02EF	RWr000F	Operation mode(Response)	

Occupies 2 stations				
Station	Buffer Address	Register Master Instrument	Contents	Remarks
1	02E0	RWr0000	Indicate value(NET weight value/ GROSS weight value)	
	02E1	RWr0001		
	02E2	RWr0002	Error code	
	02E3	RWr0003	Error assistance code	
2	02E4	RWr0004	General data area	
	02E5	RWr0005		
	02E6	RWr0006	Command No.(Response)	
	02E7	RWr0007	Operation mode(Response)	

Occupies 1 station				
Station	Buffer Address	Register Master Instrument	Contents	Remarks
1	02E0	RWr0000	Indicate value(NET weight value/ GROSS weight value)	
	02E1	RWr0001		
	02E2	RWr0002	Error code	
	02E3	RWr0003	Error assistance code	

① Net weight value(4 stations,2 stations)

Area for displaying the net weight value(4 stations,2 stations)

Data type : 32 bit binary with sign

Range of setting value : - 99 999 ~ 99 999

② Gross weight value(4 stations)

Area for displaying the gross weight value(4 stations)

Data type : 32 bit binary with sign

Range of setting value : - 99 999 ~ 99 999

③ Error code(4 stations,2 stations,1 station)

Refer to below table of error assistance code too.

Area for displaying the error code generating in the main body of the indicator.

Data type : 16 bit binary

Range of setting value : 0 ~ 255

④ Error assistance code(4 stations,2 stations,1 station)

Area for displaying the error No. generating in the main body of the indicator.

Data type : 16 bit binary

Range of setting value : 0 ~ 255

Error code	Buffer address	Contents
0	0	No error
99	0	In case of setting the unspecified data in command No.
1	1	In case of the instrument is "Calibration mode", "Fine adjustment mode" "Check mode" and "Monitor mode"
1	2	In case of setting the ZERO or tare weight at the prohibition condition.
1	13	In case of the data setting other than specification in general data area.
1	14	In case of connecting error of internal.

⑤ General data area(4 stations,2 stations)

When the setting value reading out command is ordered by using the general command request (Request 2), this area displays the setting value.

Data type : 32 bit binary with sign.

Range of setting value : - 99 999 ~ 99 999

⑥ Command No.(Response) (4 stations,2 stations)

When the command order is executed by the general command request (Request 2), this area displays that command No.

Data type : 8 bit binary

⑦ Operation mode (Response) (4 stations,2 stations)

When the changeover of the operation by the operation mode changeover request (Request 3), this area displays the mode.

Data type : 8 bit binary

⑧ Indicate value(NET weight/ GROSS weight) (2 stations,1 station)

It is area which showing the GROSS weight value or NET weight value.

Data type : 32 bit binary with + or -

Range of setting value : - 99 999 ~ 99 999

6-2. Relay zone

(1) Remote input (Master This instrument)

Occupies 4 stations			
Device NO.	Buffer address	Contents	Classification
RY0000	0160	Setting value writing request (Request 1)	Communication
RY0001			
RY0002		General command request (Request 2)	
RY0003		Selection of writing/Reading out. (R/W)	
RY0004		Operation mode changeover request (Request 3)	
RY0005			
RY0006			
RY0007			
RY0008			
RY0009			
RY000A			
RY000B			
RY000C			
RY000D			
RY000E			
RY000F			
RY0010	0161	ZERO	Control signal
RY0011			
RY0012		A/Z ON	
RY0013		A/Z OFF	
RY0014			
RY0015			
RY0016			
RY0017			
RY0018			
RY0019			
RY001A			
RY001B			
RY001C			
RY001D			
RY001E			
RY001F			
.	0162 ~ 0166		
RY006F			
RY0070	0167	System reservation zone	
RY0071			
RY0072			
RY0073			
RY0074			
RY0075			
RY0076			
RY0077			
RY0078		Initial data processing complete flag	
RY0079		Initialed data set request flag	
RY007A		Error reset request flag	
RY007B			
RY007C			
RY007D			
RY007E			
RY007F			

Occupies 2 stations				
Device NO.	Buffer address	Contents	Classification	
RY0000	0160	Setting value writing request (Request 1)	Communication	
RY0001				
RY0002		General command request (Request 2)		
RY0003		Selection of writing/Reading out. (R/W)		
RY0004		Operation mode changeover request (Request 3)		
RY0005				
RY0006				
RY0007				
RY0008				
RY0009				
RY000A				
RY000B				
RY000C				
RY000D				
RY000E				
RY000F				
RY0010	0161	ZERO	Control signal	
RY0011				
RY0012		A/Z ON		
RY0013		A/Z OFF		
RY0014				
RY0015				
RY0016				
RY0017				
RY0018				
RY0019				
RY001A				
RY001B				
RY001C				
RY001D				
RY001E				
RY001F		Select NET weight value/ GROSS weight value		
.	0162			
RY002F				
RY0030	0163	System reservation zone		
RY0031				
RY0032				
RY0033				
RY0034				
RY0035				
RY0036				
RY0037				
RY0038			Initial data processing complete flag	
RY0039			Initialed data set request flag	
RY003A			Error reset request flag	
RY003B				
RY003C				
RY003D				
RY003E				
RY003F				

Occupies 1 station				
Device NO.	Buffer address	Contents	Classification	
RY0000	0160	ZERO	Communication	
RY0001				
RY0002		A/Z ON		
RY0003		A/Z OFF		
RY0004				
RY0005				
RY0006				
RY0007		Select NET weight value/ GROSS weight value		
RY0008				
RY0009				
RY000A				
RY000B				
RY000C				
RY000D				
RY000E				
RY0010		0161		System reservation zone
RY0011				
RY0012				
RY0013				
RY0014				
RY0015				
RY0016				
RY0017				
RY0018	Initial data processing complete flag			
RY0019	Initialed data set request flag			
RY001A	Error reset request flag			
RY001B				
RY001C				
RY001D				
RY001E				
RY001F				

① Setting value writing request (Request 1)

Requests writing of the data set in special data area. (RWw0000–RWw000B).

ON : In the request of writing

OFF : After confirming “Setting value writing response (Response 1)” of remote input.

② General command request (Request 2)

Writing/Reading out by the command order is requested.

Please use together with writing/reading out selection (R/W).

ON : In the request of writing/reading out

OFF : After confirming “Setting value writing response (Response 2)” of remote input.

③ Selection of writing or reading out(R/W)

Select writing or reading out by the command order.

Writing the data set in general–purpose data area (RWw000C–RWw000D) by command NO. (RWw000E) is ordered for writing.

Reading out the data set in general–purpose data area (RWw000C–RWw000D) by command NO. (RWw000E) is ordered for reading out.

ON : Reading out

OFF : Writing

- ④ Operation mode changeover request (Request 3)
 Requests the writing of the data set in operation mode (RWw000F).
 ON : In the request of writing request.
 OFF : After confirming “Operation mode changeover response (Response 3)” of remote input.
- ⑤ ZERO
 Execute the zero set.
 ON : In requesting the execution of zero set.
 OFF : Normal
- ⑥ A/Z ON
 Start an automatic zero.
 ON : In the request of starting the automatic zero.
 OFF : Normal
- ⑦ A/Z OFF
 Clear the automatic zero.
 ON : In the request of A/Z clear.
 OFF : Normal
- ⑧ Initial data processing complete flag
 Send the initial processing complete flag when it will receive [RX078] command.
 ON : Completing process.
 OFF : Normal
- ⑨ Initial data setting request flag
 Request the initialization of the instrument.
 ON : In the request of initialization.
 OFF : Normal
- ⑩ Error reset requesting flag
 When the error generation is notified with error condition flag (RX007A), request the release of the error.
 ON : In the request of clear
 OFF : Normal
- ⑪ Indicate value NET weight value/GROSS weight value command (2 stations, 1 station)
 Select the indication value [NET] or [GROSS] in remote resistor area when the station occupies 1 or 2.
 ON : NET weight value (Same value of remote resistor at the occupies 4 stations)
 OFF : GROSS weight value (Same value of remote resistor at the occupies 4 stations)

(2) Remote output(Instrument Master)

Occupies 4 stations			
Device NO.	Buffer address	Contents	Classification
RX0000	00E0	Setting value writing request (Response 1)	Communication
RX0001			
RX0002		General command response (Response 2)	
RX0003		Writing/reading out selection response (R/W response)	
RX0004		Operation mode changeover response(Response 3)	
RX0005			
RX0006		CPU normal operation	
RX0007			
RX0008		Decimal point position 1	
RX0009		Decimal point position 2	
RX000A		Decimal point position 4	
RX000B			
RX000C			
RX000D			
RX000E			
RX000F			
RX0010	00E1	S0	Control output
RX0011		S1	
RX0012		S2	
RX0013		S3	
RX0014		S4	
RX0015			
RX0016			
RX0017			
RX0018			
RX0019			
RX001A		In the holding	
RX001B			
RX001C			
RX001D			
RX001E			
RX001F		Abnormal load value	
RX0020	00E2 ~ 00E6		
RX006F			
RX0070	00E7	System reservation zone	
RX0071			
RX0072			
RX0073			
RX0074			
RX0075			
RX0076			
RX0077			
RX0078			
RX0079		Initial data setting request flag	
RX007A		Error reset request flag	
RX007B		Remote ready	
RX007C			
RX007D			
RX007E			
RX007F			

Occupies 2 stations				
Device NO.	Buffer address	Contents	Classification	
RX0000	00E0	Setting value writing request (Response 1)	Communication	
RX0001				
RX0002		General command response (Response 2)		
RX0003		Writing/reading out selection response (R/W response)		
RX0004		Operation mode changeover response(Response 3)		
RX0005				
RX0006		CPU normal operation		
RX0007				
RX0008		Decimal point position 1		
RX0009		Decimal point position 2		
RX000A		Decimal point position 4		
RX000B				
RX000C				
RX000D				
RX000E				
RX000F				
RX0010	00E1	S0	Control output	
RX0011		S1		
RX0012		S2		
RX0013		S3		
RX0014		S4		
RX0015				
RX0016				
RX0017				
RX0018				
RX0019				
RX001A		In the holding		
RX001B				
RX001C				
RX001D				
RX001E				
RX001F		Abnormal load value		
RX0020	00E2			
.				
RX002F				
RX0030	00E3	System reservation zone		
RX0031				
RX0032				
RX0033				
RX0034				
RX0035				
RX0036				
RX0037				
RX0038				
RX0039			Initial data setting request flag	
RX003A			Error reset request flag	
RX003B			Remote ready	
RX003C				
RX003D				
RX003E				
RX003F				

Occupies 1 station			
Device NO.	Buffer address	Contents	Classification
RX0000	00E0	S0	Communication
RX0001		S1	
RX0002		S2	
RX0003		S3	
RX0004		S4	
RX0005			
RX0006			
RX0007			
RX0008			
RX0009			
RX000A		In the holding	
RX000B			
RX000C			
RX000D			
RX000E			
RX000F		Abnormal load value	
RX0010	00E1	System reservation zone	
RX0011			
RX0012			
RX0013			
RX0014			
RX0015			
RX0016			
RX0017			
RX0018			
RX0019			Initial data setting request flag
RX001A			Error reset request flag
RX001B			Remote ready
RX001C			
RX001D			
RX001E			
RX001F			

① Setting value writing response (Response 1)

The end of writing by the set value writing request (request 1) is notified.

ON : In completion of writing

OFF : After confirming OFF of “Setting value writing request(Request 1)”

② The end of the command instruction by the general command request (request 2) is notified.

ON : In the completion of command instruction

OFF : After confirming OFF of the general command request (Request 2)

③ Writing/Reading out selecting response (R/W response)

Notify the status of write/reading out by the command instruction when notifying by the general command response (response 2).

④ Operating mode changeover response(Response 3)

Notify that the end of the operation mode changeover by the operation mode changeover request (request 3(RY0004)).

ON : In the completion of the changeover

OFF : After confirming the OFF of the operation mode changeover request(Request 3)

- ⑤ CPU normal operation
Notify that CC–Link interface is operating normally. Reverse the status of ON/OFF in 0.5 seconds.
- ⑥ Decimal point position 1, 2, 3 or 4
Notify the decimal point position of the load value by the binary value of three points. This output is updated by turning on the power supply, and initialed data set request flag (RY0079).
- | | |
|---|--------------------|
| 0 | : No decimal point |
| 1 | : 10^0 digit |
| 2 | : 10^2 digit |
| 3 | : 10^3 digit |
| 4 | : 10^4 digit |
- ⑦ S0 ~ S4
Notify the condition of S0 ~ S4. The same condition with S0 ~ S4 of the indicator
- ⑧ Holding
Notified whether the load value is holding.
- | | |
|-----|----------------|
| ON | : Holding |
| OFF | : Free running |
- ⑨ Abnormal load value
Notifies when the load value is “OL” or “ - OL”.
- | | |
|-----|---------------------------|
| ON | : When abnormality occurs |
| OFF | : Normal |
- ⑩ Initialed data set completion flag
Notify the end of initialization when there is a request with initialed data set request flag (RY0079).
- | | |
|-----|----------------------------|
| ON | : In the completion of set |
| OFF | : Normal |
- ⑪ Error condition flag
Notify when the error occurs in the indicator. After the error is released, it is reset with error reset request flag (RY007A).
- | | |
|-----|------------------------------|
| ON | : In the occurrence of error |
| OFF | : Normal |
- ⑫ Remote ready
Notified to be able to complete initialization and to communicate.
- | | |
|-----|---------------------------|
| ON | : Possible to communicate |
| OFF | : In the initialization |

7. Operation method

7-1. Writing the set value (Special data area)

The set value is set in the special data area.

The instrument recognizes that “Set writing request (request 1) RY0000” was turned on, and it writes the data set in “Special data area (RW0000–RW0009)” into the indicator.

It responds to the master station by “Set value writing response RX0000 (response 1)” after writing is completed.

Time chart

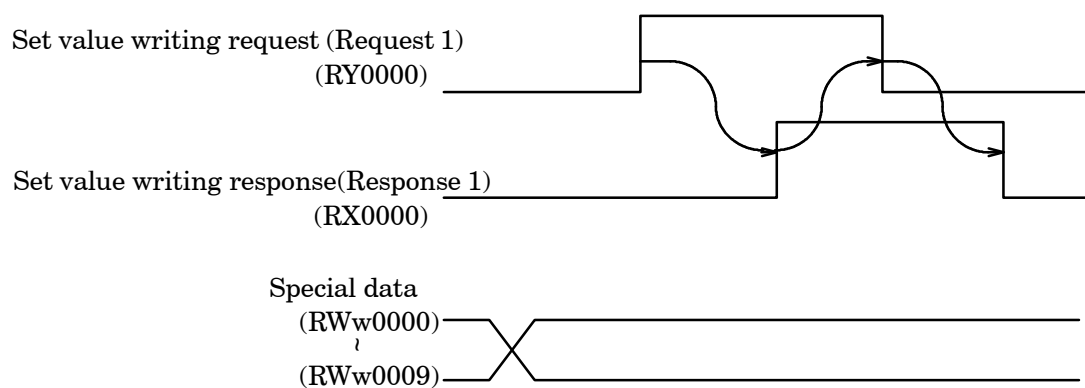

7-2. Writing/Reading by general command

Data is set in the general data area and command No. is set in the command No. area.

The instrument recognize that “General command request RY0002 (Request 2)”, and it execute to write the data set in “General data area (RWr000C ~ 000D)” by “Selection of writing/reading out (RY0003)” or “Command No.(RWw000E)”, or to reading the data into “General data area (RWw000C ~ 000E)” to the instrument.

It responds to the master station by ”General command response RX0000 (response 2)” after writing is completed.

① Writing request

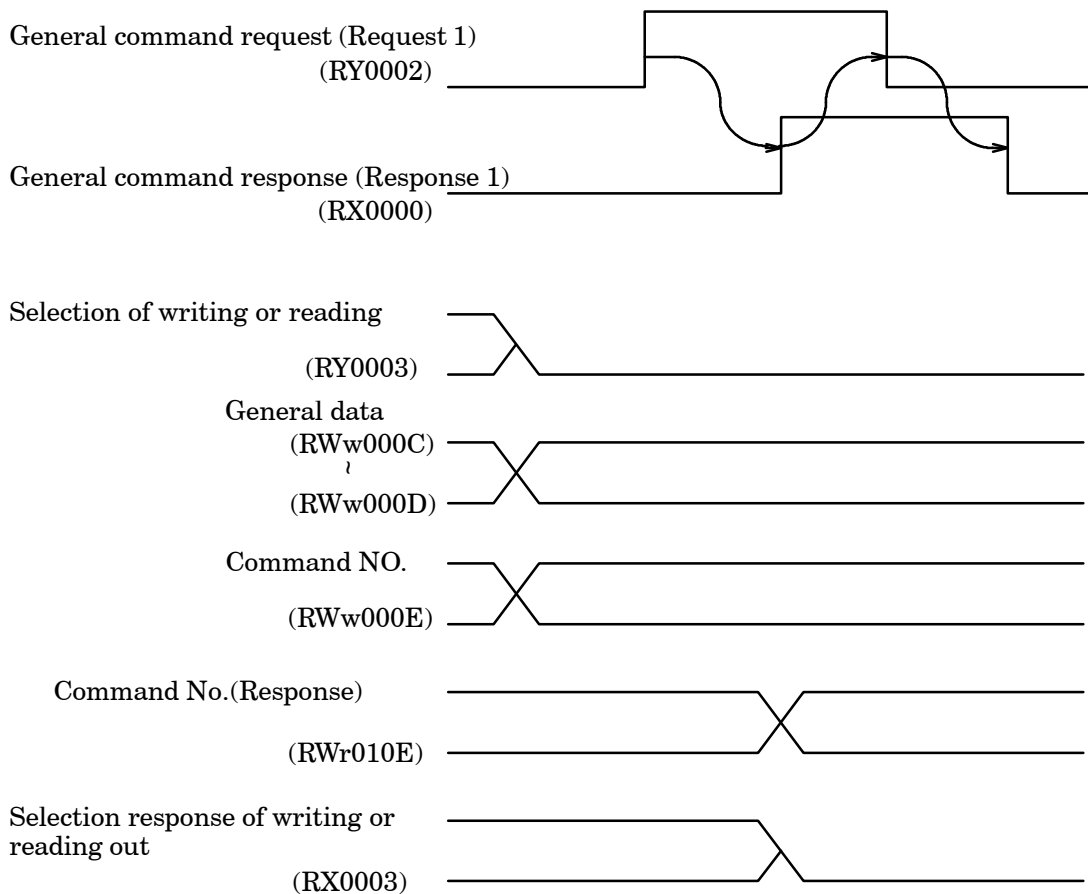

② Reading out request

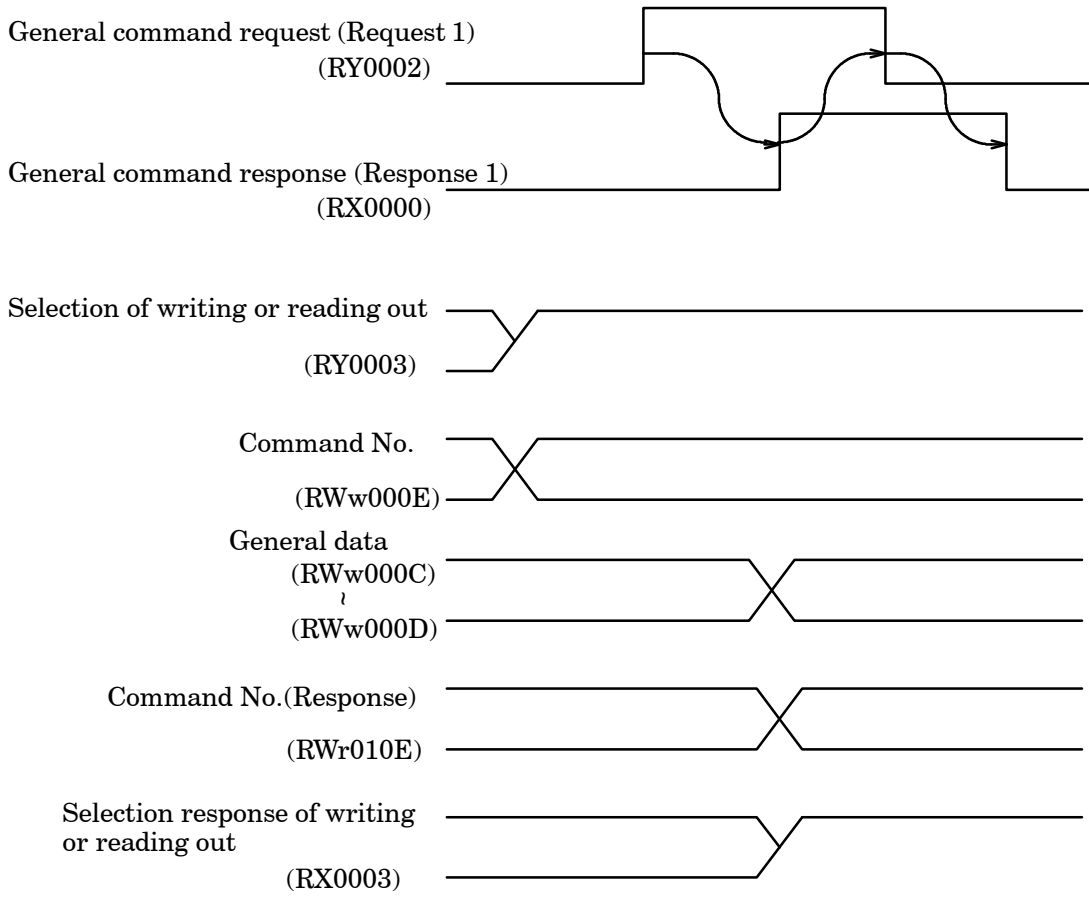

7-3. Shift to status where it is possible to communicate

“Remote READY (RX007B)” is turned on along with the power supply turning on after initialization (set initialing) completion is done and it is assumed the status where it is possible to communicate.

Moreover, remote READY is turned off when ”Set initial request (RY0079)” transmitted by the master station is turned on, and initialization is executed. It responds to the master station after initialization is completed by turning on ”Set initial response (RX0079)”.

That the master station recognizes turning on ”Set initial response (RX0079)”, and ”Set initial response (RX0079)” is turned off makes that ”Set initial request (RY0079)” is turned off, and remote ready is turned on.

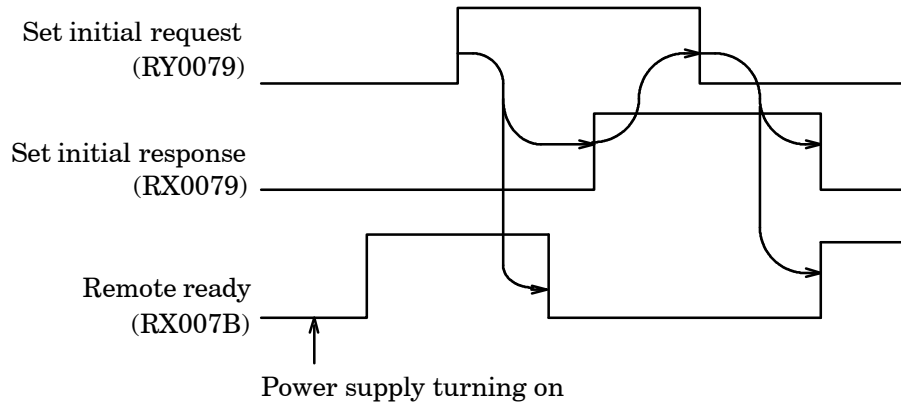

7-4. Error condition/Reset request flag

The state sequence which an error is detected and the reset sequence is shown.

When an error is detected, the remote ready [RX(n+7)B] is turned off and the error condition flag [RX(n+7)A] is turn on.

The error condition flag [RX(n+7)A] is turn off when the error reset request(ing) flag [RY(n+7)A] transmitted by the master station is turned on.

Afterwards, the remote ready [RX(n+7)B] is turn on when the error reset request(ing) flag [RY(n+7)A] transmitted by the master station is turned off.

When an error is detected, reset the error as the following sequence.

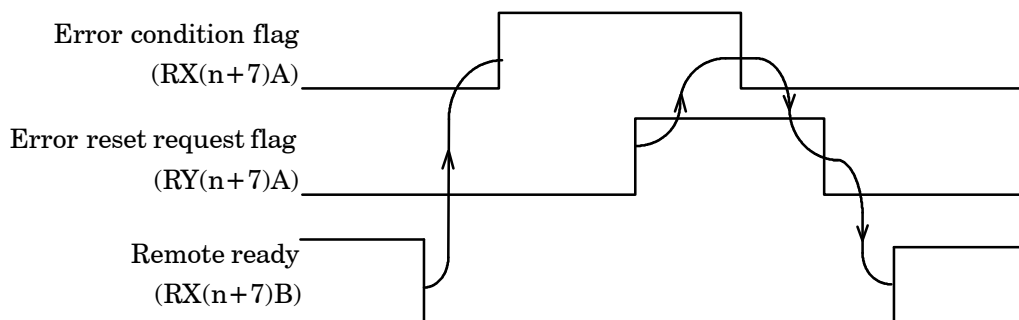

7-5. CPU normal operation signal

When the instrument operates normally, the condition of "CPU normal operating signal (RX0006)" is reversed at 0.5 seconds interval.

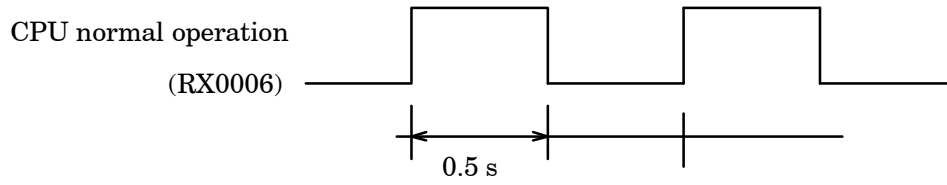

8. Specifications of interface

Baud rate	Selectable from 156 k, 625 k, 2.5 M, 5 M and 10 Mbps
Occupied stations No.	Selectable from 1,2 or 4 stations.
Communication method	Polling method
Synchronous method	Bit synchronization method
Encoded system	NRZI
Transmission path form	RS485 bus
Transmission format	HDLC conforming
Remote station number	In the case of 1 station occupied, No's.01 to 64 can be selectable. In the case of 2 stations occupied, No's.01 to 63 can be selectable. In the case of 4 stations occupied, No's.01 to 61 can be selectable.
Error control system	CRC (X16 + X12 + X5 + 1)
Connected cable	Shield addition twisted-pair cable
Cable length	156 kbps : 1 200 m 625 kbps : 600 m 2.5 Mbps : 200 m 5 Mbps : 150 m 10 Mbps : 100 m
Numbers of connection	In the case of 1 station occupied, 64 units at maximum. In the case of 2 stations occupied, 32 units at maximum. In the case of 4 stations occupied, 16units at maximum.
Termination	Resistance externally attached
Status LED	RUN, ERR, SD, RD

- The contents of this manual may subject to change without notice.

HEAD QUARTER : **MINEBEA CO., LTD.**

4106-73 Miyota, Miyota-machi, Kitasakugun, Nagano-ken 389-0293, Japan

☎0267-32-2200 FAX.0267-31-1350

Measuring Components Business Unit

FUJISAWA PLANT 1-1-1, Katase, Fujisawa-shi Kanagawa-ken, 251-8531 Japan

☎0466-22-7151 FAX.0466-22-1701

KARUIZAWA PLANT 4106-73 Miyota, Miyota-machi, Kitasakugun, Nagano-ken 389-0293, Japan

☎0267-31-1309 FAX.0267-31-1350

HOME PAGE ADDRESS **<http://www.minebea-mcd.com>**