

Minebea

MINEBEA CO., LTD.

INSTRUCTION MANUAL

DIGITAL INDICATOR CSD-701B

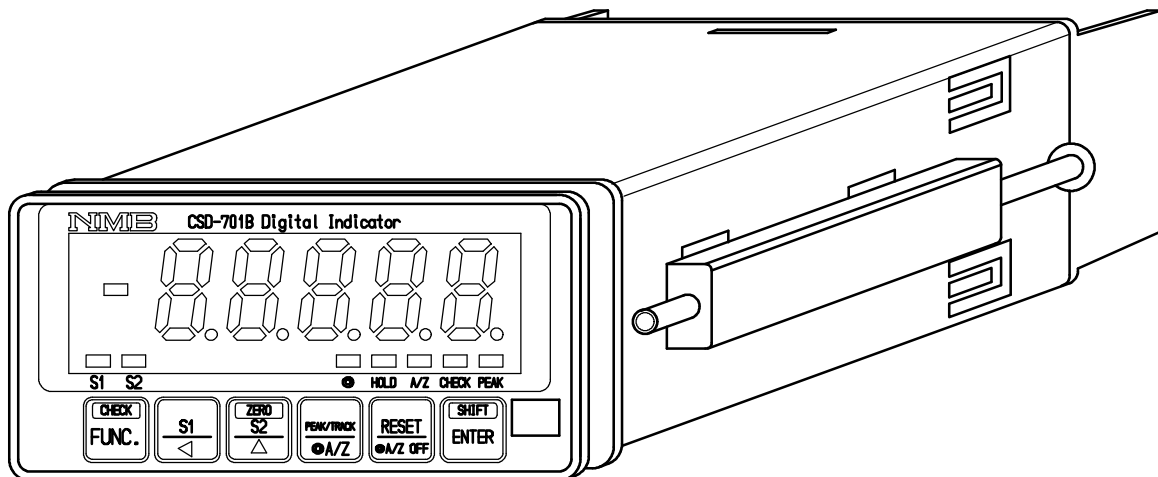

Note : Please read this Instruction Manual carefully before use.
Be sure to follow the items that require attention described in the manual.
Keep the manual at hand so that you can pick it up and read it as soon as
necessity requires.

Forwards

Thank you very much for your purchasing Minebea's Digital Indicator CSD-701B.

This manual explains installation procedures and connecting method and also operating method for the Digital Indicator CSD-701B. Make use of it properly after reading through the manual carefully.

Be sure to deliver the manual to the end user. Moreover, the end user should keep the manual at hand after reading it over.

This manual is intended for the technical experts to read.

The contents of the manual may subject to change for improvement without notice.

Marks and arrangements used in this manual

The following marks are attached to the explanation on the matters that indicate “Don’t do this.”, “Take care.” and “For reference”.

Be sure to read these items where these marks are attached.



Warning

Warning may cause injury or accident that may harm to the operator.
Don’t do these things described here.



Caution during operation and working.

Be sure to read the item to prevent malfunction.

Mark during operation.



Press the switch.

For safe operation

Be sure to read this instruction manual before use.

1. Installation place



Use the instrument where the temperature/humidity specifies with the range as follows :

Environmental temperature : - 10 to 50

Environmental humidity : Less than 85 %R.H. (Non condensing)

(1) Location where installation is not allowed.



Warning Don't locate the instrument on the places as follows :
It may cause an unexpected faulty in the instrument.

- Don't locate the instrument in direct and/or high temperature area.
- Don't use the instrument in a high humid area.
- Don't install the instrument where there are vibrations and shocks.
- Don't use the instrument where there is excess of dusts and fine particles.
- Don't use the instrument where there are corrosive gas and salt and like that.
- Don't install the instrument where there is rapid change of temperature and humidity.
- Don't install the instrument near the devices that are magnetized or generate an electromagnetic field.
- Don't install the instrument where the instrument may be affected by radioactivity or radial rays.
- Avoid the location where chemical reaction may take place such as in a laboratory, or like that.

(2) Installation



When installing the instrument, install as referring to the following figures and secure the space around the instrument.

Each dimensions of the instrument and required dimensions for the environmental spaces are as follows:

Outline dimensions

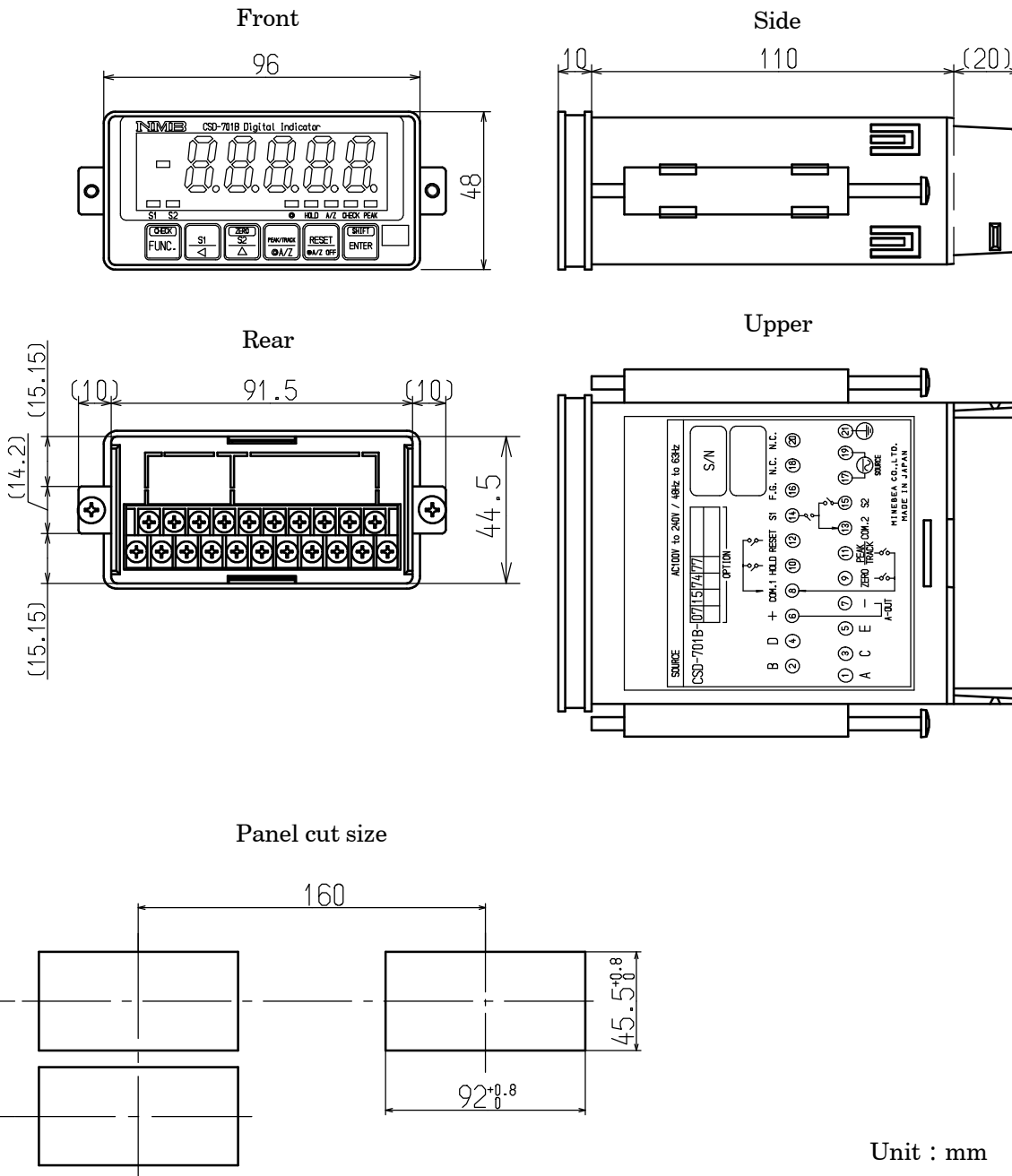

Unit : mm

2. Power supply



Warning

Be sure to check that the power supply is off in connecting each cable. If the work is done while the power is on, there may have the case that electric shock to the operator or even may have damage to the instrument.



Before supplying the power, check that the indication of power supply voltage/specifications for the instrument and the power going to supply should be the same.

If they are not equal, contact with Minebea.

If you use the instrument without checking them, it may cause a damage in the instrument or electric shock to the operator.



Earth wire should be grounded securely.

When earth wire is not connected, it may cause a malfunction of the instrument or electric shock to the operator.

3. Application note



Warning

Before using a new instrument or exchanging the strain gage applied transducer for a new one, be sure to make calibration. If calibration will not be made, the correct measuring results may not be obtained nor which may cause malfunction in the instrument and there may exist damage in peripheral equipments.

Besides, even though calibration has been made, there may occur the similar case when the results are not correct, so make calibration, again.



Warning

In case of using the instrument, check that the connections are executed properly. If not connected properly, the correct measuring result will not be obtained, nor it may cause malfunctions of the instrument, damage to the peripheral equipments or even more serious accidents.



Warning

When change of setting is made carelessly on the instrument during measurement, correct measured results may not be obtained and it may cause malfunction in the instrument and even have the possibility of damage in peripheral instruments.



Warning

Do not shock the instrument such as throwing something on it. If neglected, it may cause destruction of the parts and damage to the electrical circuits.



Warning

Do not push the panel sheet on the instrument with the excessive strong force nor push it with sharp edge object such as a driver. If neglected, it may cause a damage to the panel switch and even have the possibility of damage to resist to environments or operational performances.



Warning

Don't remove the cover of the case of the instrument, nor peel off the panel sheet nor take the instrument into pieces. If neglected, it may cause a damage to the case and the panel sheet and even have the possibility of damage to resist to environments or operational performances.





At the time of shipment from the factory, the instrument has been plated with a clear sheet on the panel sheet for protective purpose. In case of application, use the instrument after removing the clearsheet first.





History of revision

Date	Instruction Manual No.	Details of revised point
Dec. 2000	DRW.NO.EN294-1127	First Version ROM Ver. 1.000 or later
Mar. 2001	DRW.NO.EN294-1127-A	ECN No.FN01-02042 - Correction - P:49 7-1-1. Input signal for external control “During the holding operation, it is reset condition by short circuit.” “During the peak hold operation, reset condition is made by short circuit.” P:91 9-2-6 Output condition at Positive logic Output data “Yes” Condition of transistor “OFF” Output data “No” Condition of transistor “ON”
Mar. 2001	DRW.NO.EN294-1127-B	ECN No.FN01-02041 ROM Ver.1.300 or later - Correction - 5-2-1. 6th step. Add the clause “  It can be increased ~” 5-2-3. 12th step. Change the display of “SP-L” and “SP-H” 11-1. Specifications for analog Input filter “2 Hz” “1 Hz(At the “0” setting of the digital filter and stabilized filter)” - Change - 7-13. “Key lock” “Lock of key function”, According to this change, following sentence is corrected. 8-2. F-06 “Setting key lock” “Setting the lock of key function” According to this change, following sentence is also corrected.
Jun. 2001	DRW.NO.EN294-1127-C	ECN No.FN01-02085 - Correction Change the outline dimensions (upper part) - Additions 9-6-2., 9-7-2, 11-11-6. add the “Power consumption”.
Jul. 2001	DRW.NO.EN294-1127-D	- Correction - 9-2-4. (1)Equivalent circuit of input section “COM.1” “COM.” (2)Equivalent circuit of output section “ ” “ ”
Sep. 2001	DRW.NO.EN294-1127-E	Due to ECN No.FN01-02134 - Change- Operating temperature range “0 to 50 ” “ - 10 to 50 ”
May. 2003	DRW.NO.EN294-1127-F	Due to ECN No.FN03-02040 - Correction - 4-3-5.(2) “4mA to 20mA” to “DC4mA to 20mA” 7-2-4., (1), 7-15-4., 6-2., 9-1-1., 9-2-1., 9-2-2. 9-3-1., 11-7., “Display interlock” “PEAK/Net weight”
Aug. 2003	DRW.NO.EN294-1127-G	Due to ECN No.FN03-02118 - Correction - 11-2. Specifications for digital section Display range “ - 99 999” “9 999”

Date	Instruction Manual No.	Details of revised point
Apr. 2005	DRW.NO.EN294-1127-H	Due to ECN No.FN05-02035 - Addition - At the warning column in the wiring section, the clause of “ As there is a case which standard wiring color is different, please confirm the inspection data sheet of the load cell being used.” is added.
Nov. 2007	DRW.NO.EN294-1127-I	Due to ECN No.FN07-02126 - Correction - 9-2-3. “DC-37P-N made by JAE” to “Equivalent to DC-37P-NR made by JAE” 9-3-4. “DE-9S-N (JAE)” to “Equivalent to DE-9S-NR made by JAE”
May, 2010	DRW.NO.EN294-1127-J	Due to ECN No.FN10-01019A - Addition - 11-10.Accessories panel mounting gasket is added.
Oct. 2010	DRW.NO.EN294-1127-K	Due to ECN No.FN10-02140 - Change - Minebea logo is changed.

INDEX

Forwards	
Marks and arrangements used in this manual	
For safe operation	
1. Installation place	
2. Power supply	
3. Application note	
History of revision	
1. General	1
1-1. Features	1
2. Name and function of each point	2
2-1. Front panel	2
2-2. Rear panel	3
3. Installation procedures	4
3-1. Installation place	4
3-2. Location where installation is not allowed.	4
3-3. Installation	5
3-4. Applicable environment	6
4. Connecting method	7
4-1. Layout of the terminal boards	7
4-2. Note on connection	8
4-3. Connection	9
4-3-1. Connection with strain gage applied transducers	9
4-3-2. Connection with external control inputs	13
4-3-3. Connection with contact outputs	14
4-3-4. Connection with the power supply and the earth	15
4-3-5. Connection with analog outputs	16
5. Calibration procedures	18
5-1. Preparations	18
5-2. Calibration procedures	18
5-2-1. Calibration method to register the output of strain gage applied transducer at the time of maximum display after setting the load to zero	19
5-2-2. Calibration procedures to register the output of strain gage applied transducer at the time of zero and the maximum display	24
5-2-3. Calibration method to register by reading output value of strain gage applied transducer in the conditions of zero/actual load application individually	29
5-2-4. Zero fine adjustment	35
5-2-5. Span fine adjustment	37
5-2-6. Calibration procedure to apply registration again for zero point only	39
5-3. Selection of calibration methods on each condition	41
5-3-1. In case of executing the calibration on the instrument newly.	41
5-3-2. When the calibration is executed again.	45
5-4. Setting the prohibition against calibration	45
6. Operation procedure	46
6-1.  key	46
6-1-1. Operations in Measurement mode	46
6-2.  key	46

6-2-1. When operating in the measurement mode	46
6-2-2. Operation is made in another mode	47
6-3.  key	47
6-3-1. When operated in the Measurement mode.	47
6-3-2. When operated in another modes	48
6-4.  key	48
6-4-1. When operated in the Measurement mode.	48
6-4-2. When operated in another modes	48
6-5.  key	49
6-5-1. When operated in the Measurement mode	49
6-5-2. When operated in another modes.	49
6-6.  key	49
7. Function and operation	50
7-1. External control input signal and contact output signal	50
7-1-1. Input signal for external control	50
7-1-2. Contact output signal	51
7-1-3. Equivalent circuit	51
7-2. Comparator	52
7-2-1. ON/OFF of comparator S1 and S2	52
7-2-2. Change of set value	52
7-2-3. Operation on comparator S1 and S2	54
7-2-4. Comparative target for comparator S1 and S2	55
7-2-5. Hysteresis on comparator	56
7-3. How to use the filter	58
7-3-1. Digital filter	58
7-4. Zero tracking	58
7-4-1. What is zero tracking?	58
7-4-2. Setting related with zero tracking.	59
7-4-3. Cancellation for compensation by zero tracking	59
7-5. Stabilized filter	60
7-5-1. What is the Stabilized filter?	60
7-5-2. Setting related with the Stabilized filter.	60
7-6. Change of Peak function and A/Z function	61
7-7. How to use the peak hold.	62
7-8. Various functions concerning display	63
7-8-1. Selection of target of display	63
7-8-2. Selection of position of decimal point display	63
7-8-3. Load display range	63
7-9. Selection the target for HOLD	63
7-10. Change of bridge power supply voltage	64
7-11. Tare weight cancellation (A/Z)	64
7-12. Zero set	64
7-13. Lock of key function	65
7-14. CHECK value	65
7-15. How to use the analog output	66
7-15-1. Scaling of analog output	66
7-15-2. Fine adjustment 1 on analog output	67
7-15-3. Fine adjustment 2 on analog output	70

7-15-4. Selection of the target of analog output	72
7-16. Memory location for setting data and so on	72
7-17. Prohibition of calibration	72
7-18. Check mode	73
7-18-1. Operating procedure for the check mode	73
7-19. Monitor mode	78
8. Function mode	80
8-1. Setting method for function mode	80
8-2. Function of Function data	82
9. Options	88
9-1. Current output	88
9-1-1. Related functions	88
9-1-2. Specifications for the current output	88
9-2. BCD output	89
9-2-1. Related function	89
9-2-2. Specifications for BCD output	89
9-2-3. Pin configurations for the BCD output connector	89
9-2-4. Equivalent circuit for input/output	90
9-2-5. Timing chart	91
9-2-6. Output condition	92
9-2-7. Selection of output logic for P.C.(Print command), and selection of its width	93
9-3. RS-232C interface	94
9-3-1. Related function	94
9-3-2. Specifications for interface	94
9-3-3. Procedures of data transfer	95
9-3-4. Pin configurations for connector pin	96
9-3-5. Data format	97
9-3-6. Communication error process	100
9-4. RS-422 interface	101
9-4-1. Related functions	101
9-4-2. Specifications on interface	102
9-4-3. Procedure of data transmission	102
9-4-4. Pin layout and wiring of Connector	103
9-4-5. Data format	104
9-4-6. Process of communication error	106
9-5. Serial interface	107
9-5-1. Related function	107
9-5-2. Specifications for Interface	107
9-5-3. Connecting method and internal equivalent circuit	108
9-5-4. Data format	109
9-5-5. Explanation of format data	110
9-5-6. Explanation of output type	110
9-6. Power supply voltage DC12 V(CSD701B-P66)	111
9-6-1. Layout of the terminal boards	111
9-6-2. Connection with the power supply and the earth	112
9-7. Power supply voltage DC24 V(CSD701B-P67)	113
9-7-1. Layout of the terminal boards	113
9-7-2. Connection with the power supply and the earth	114
10. Trouble shooting	115

10-1. Execute trouble shooting	116
10-2. Optional check	125
10-3. Error display	131
11. Specifications	132
11-1. Specifications for analog section	132
11-2. Specifications for digital section	132
11-3. Front panel sheet key function	133
11-4. External control function	133
11-5. Comparator function	134
11-6. Contact output signal	134
11-7. Various kinds of functions	134
11-8. General specifications	134
11-9. Standard specifications at the shipment	135
11-10. Accessories	135
11-11. Options	135
11-11-1. Current output	135
11-11-2. BCD output	135
11-11-3. RS-232C interface	135
11-11-4. RS-422 interface	137
11-11-5. Serial interface	137
11-11-6. Power supply voltage	137
11-12. Outline dimensions	138
12. Warranty	139
12-1. Warranty	139
12-2. Repair	139
13. Appendix	140
13-1. Replacement of fuse	140
13-2. Character's pattern for display	142
13-3. Setting table for functions	143

1. General

The instrument is a digital indicator for the application of strain gage applied transducer.

1-1. Features

Main features for CSD-701B are as follows :

(1) Compact size and light weight

48 mm × 96 mm × 120 mm Approx.0.3 kg (Without any options)

(2) The A/Z function and the peak holding function can be used by the selection.

2. Name and function of each point

2-1. Front panel

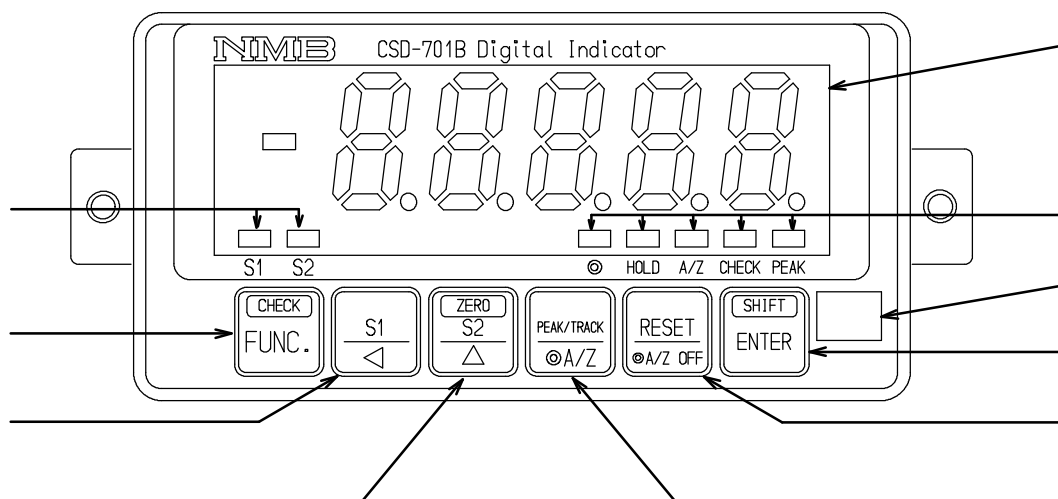

① Load display section

The load data is shown in the Measurement mode, and status or set value is shown in various kinds of Calibration mode and Setting mode.

② Judgement display

Compared results by comparator function can be displayed.

③ Status display

Lights up when selecting A/Z or A/Z OFF function in the Function mode.

In the same way, light off when selecting Peak hold function in the Function mode.

HOLD Lights up when between the HOLD and COM.1 at the external control input is shorted.

A/Z Lights up at the time of executing Tare weight cancellation(A/Z ON).

Lights off with the tare weight cancellation clear.

(Effective when selecting the A/Z or A/Z OFF function in the function mode.)

CHECK Lights up when the CHECK is ON.

PEAK Lights up when selecting the Peak mode.

④ key

Used when shifting to the Function mode.

Also, by pressing this key and the  key together, it is used when the CHECK value is turned on and off

⑤ key

Used when calling the S1 set value changeover mode, or carrying digit at the time of various kinds of settings.

⑥  key

Used when calling the S2 set value changeover mode, or for the increment of values at the time of various kinds of settings.

Also, by pressing this key and the  key together, it will execute the set of zero(One-touch zero adjustment).

⑦  key

Used for making the changeover mode of Peak/Track, or executing the Tare weight cancellation (A/Z ON).

(Changeover of Peak hold function and A/Z function depends on the setting of Function mode.)

⑧  key

Used for the reset of Peak value, or for Tare weight cancellation clear(A/Z OFF).

(Changeover of Peak hold function and A/Z function depends on the setting of Function mode.)

⑨  key

Used for registering set values at the time of various kinds of settings.

Also, by pressing this key and the  key together, it is used when the CHECK value is turned on and off.

Also, by pressing this key and  key together, it will execute the set of zero(One-touch zero adjustment).

⑩ Position of pasting the Unit seal

As necessity requires, paste the Unit seal attached.

2-2. Rear panel

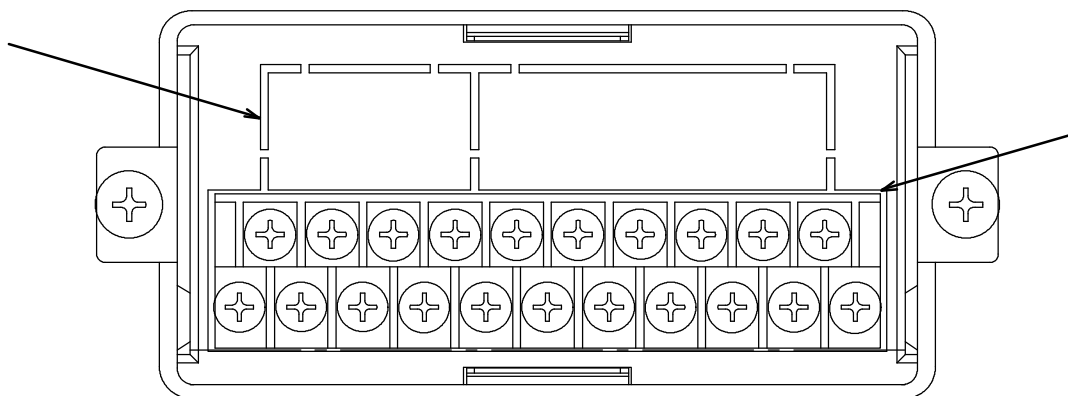

① Terminal board

Connects with external control input, contact output, various kinds of strain gage applied transducer such as load cell, analog output, AC power supply, and a grounding wire.

② Installing section for options

Whichever one can be installed from the optional BCD-OUT, RS-232C, RS-422 or serial interface.

3. Installation procedures

3-1. Installation place



Use the instrument where the temperature/humidity specifies within the range as follows:

Environmental temperature : - 10 to 50

Environmental humidity : 85 %RH or less(Non condensing.)

3-2. Location where installation is not allowed.



Warning

Don't locate the instrument on the places such as follows:

It may cause an unexpected faulty in the instrument.

- Do not expose the instrument in direct sunlight and/or high temperature area.
- Do not use the instrument in a high humid area.
- Do not install the instrument where there is high mechanical vibrations and shock.
- Do not use the instrument where there are excess of dusts and fine particles.
- Do not install the instrument where there include any corrosive gas or any salty atmosphere.
- Do not install the instrument where there is rapid change of temperature and humidity.
- Do not install the instrument near the devices that are magnetized or generate an electromagnetic field.
- Do not install the instrument where there may suffer radioactivity or radioactive rays.
- Avoid the location where chemical reaction may take place such as in a laboratory, or like that.

3-3. Installation



When installing the instrument, install as the following figures and secure the space around the instrument.

Each dimensions of the instrument and required dimensions for the environmental spaces are as follows:

Outline dimensions

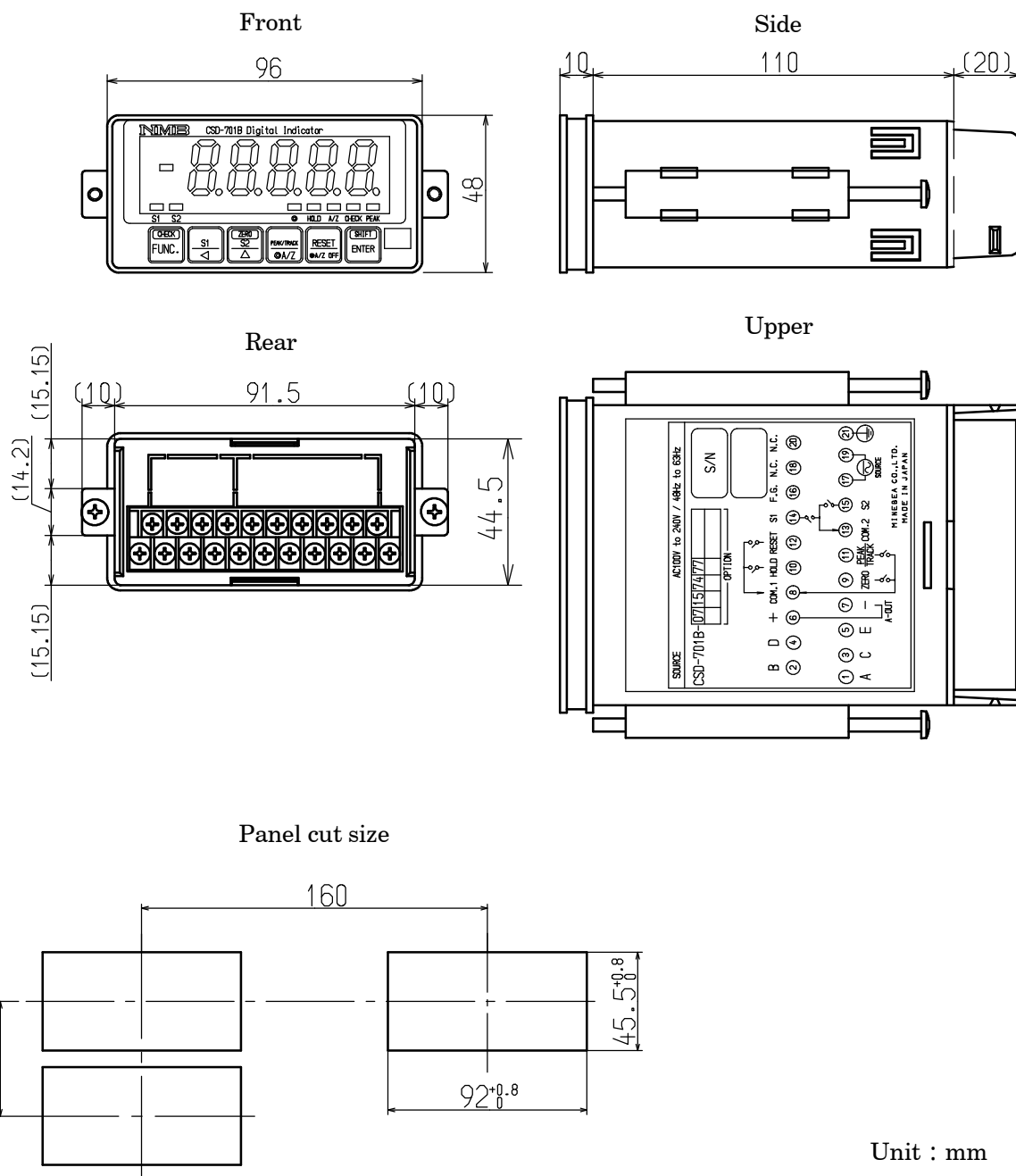

3-4. Applicable environment

Warning: The instrument may subject to use in a highly humid area or in full of powder dust.

In such a case, use the instrument by inserting the panel mount gasket attached between the control panel (cabinet) and the main body.

By inserting the panel mount gasket, the front panel section becomes IP65 (International Protection Code) or equivalent in dust-proof and water-proof construction.

* Care should be taken when handling the panel mount gasket, since there are up and down directions.

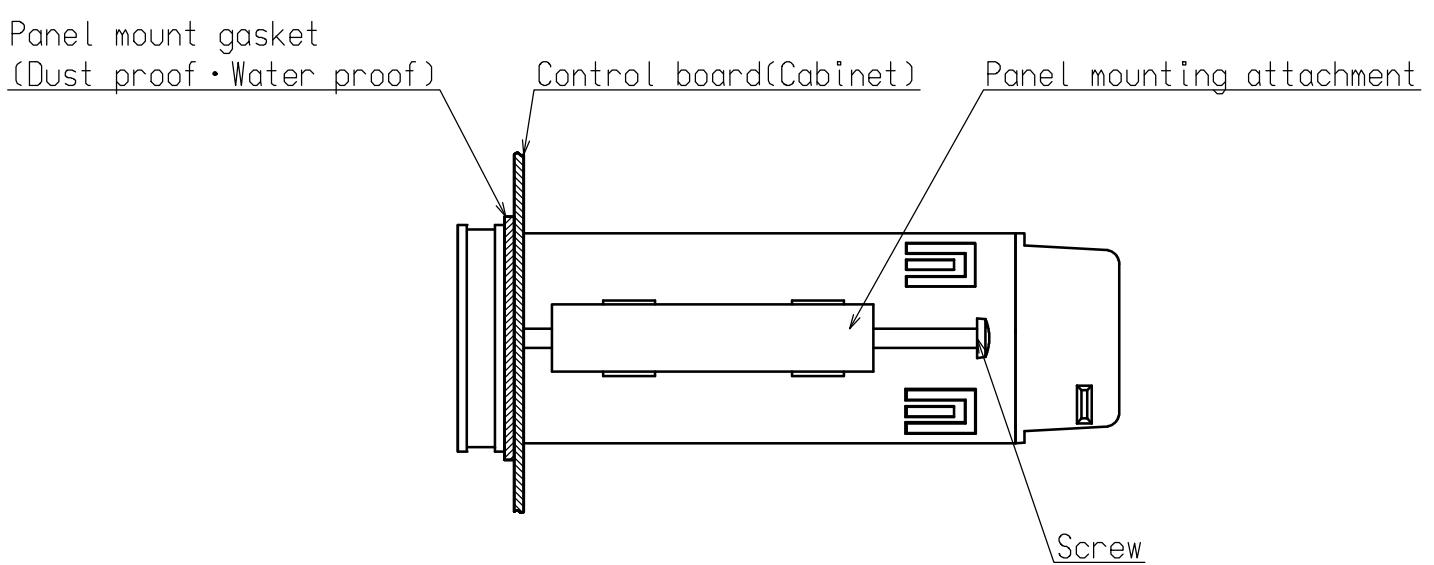

4. Connecting method

4-1. Layout of the terminal boards

There is one terminal board containing 21 point of terminals in the panel.

Layout of terminal boards are shown in the following figure. :

Terminal No.	Descriptions	Applications	Terminal No.	Descriptions	Applications
1	A	Strain gage applied transducer	11	PEAK/TRACK or A/Z	External control input
2	B		12	RESET or A/Z OFF	
3	C		13	COM.2	Contact output
4	D		14	S1	
5	E		15	S2	
6	A-OUT +	Analog output	16	FG	Frame ground
7	A-OUT -		17	SOURCE	AC power supply
8	COM.1	External control input	18	N.C.	
9	ZERO		19	SOURCE	AC power supply
10	HOLD		20	N.C.	
			21		Ground



The COM.1(Terminal No.8) and COM.2(Terminal No.13) are isolated.

4-2. Note on connection

 **Warning** In case of connection with the instrument, keep strictly to the following items. If neglected, it may cause an unexpected failure or a damage to the instrument.

- Be sure to set the power supply to OFF, when the connection will be made.
- Since the terminal boards at rear side of the instrument is made of resin, take care not to drop it down or not to apply strong impact.
- Recommended torque to tighten the terminal screws for terminal board should be as follows :

	Torque to tighten the terminal screws
Terminal board	0.6 N·m

- The suitable crimp type terminal lugs for the terminal board are as follows:

	Width of crimp type terminal lugs	Suitable crimp type terminal lugs
Terminal board	6.2 mm or less	1.25-3 or Y type 1.25-3.5

- Connecting cable with the instrument should be away from the noise source such as power supply line and/or I/O line for control and so on as far as possible.
- Conduit wiring should be the type of exclusive one, and avoid using with another line together.
- All of the connections should be executed securely by referring to the Instruction manual for the instrument.

4-3. Connection

4-3-1. Connection with strain gage applied transducers

The instrument can connect with strain gage applied transducers, such as load cell, pressure transducer and so on. Here, we will describe the example of connections with load cell, so the connection with other type of strain gage applied transducers shall be proceeded in the same way.



- 1 When tension is applied with the application of tension type or universal(compression/tension) type of load cell, and display of “+” direction is required, connect “Green” with Terminal No.2 and “Blue” with Terminal No.4 individually. As there is a case which standard wiring color is different, please confirm the inspection data sheet of the load cell being used.
- 2 When the length of CAB-502 is more than 30 m totally, there may have the case that the accuracy is out of warranty because the resistance of cable makes the input voltage of the instrument decreased.

① Connection with 1 piece of load cell and CSD-701B

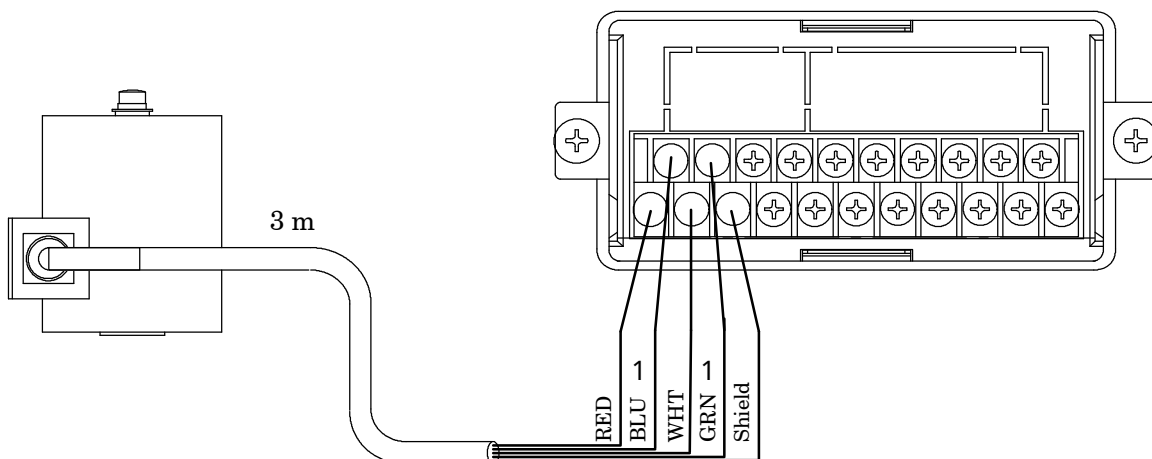



1 When tension is applied with the application of tension type or universal(compression/tension) type of load cell, and display of “+” direction is required, connect “Green” with Terminal No.2 and “Blue” with Terminal No.4 individually. As there is a case which standard wiring color is different, please confirm the inspection data sheet of the load cell being used.

2 When the length of CAB-502 is more than 30 m totally, there may have the case that the accuracy is out of warranty because the resistance of cable makes the input voltage of the instrument decreased.

② Connection with 1 piece of load cell and Junction box for extension use(B-304) and CSD-701B.

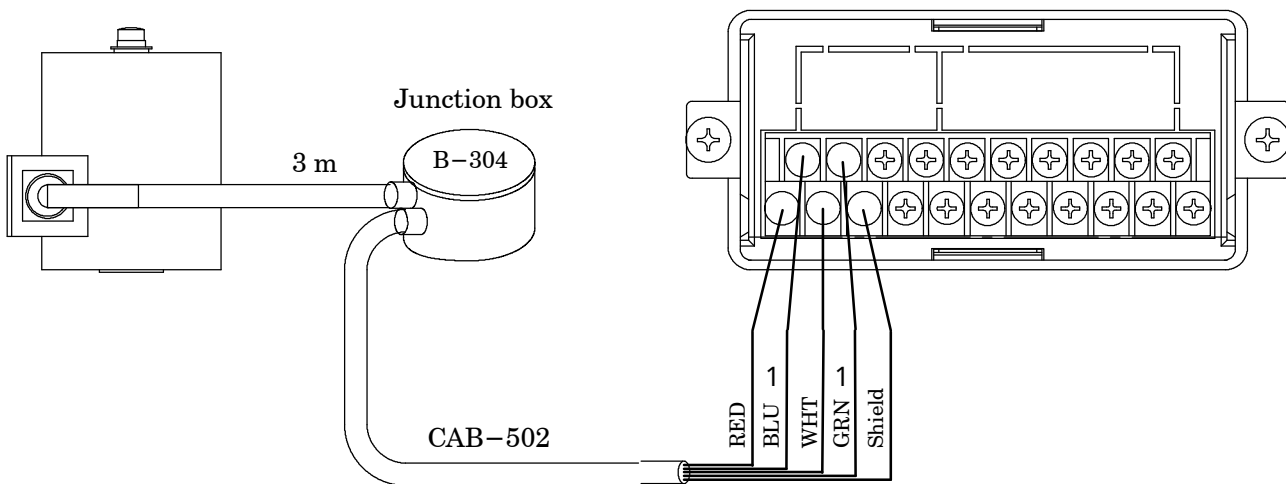

2 (Total length of CAB-502 is within 30 m)

Internal wiring diagram of B-304

to load cell ←

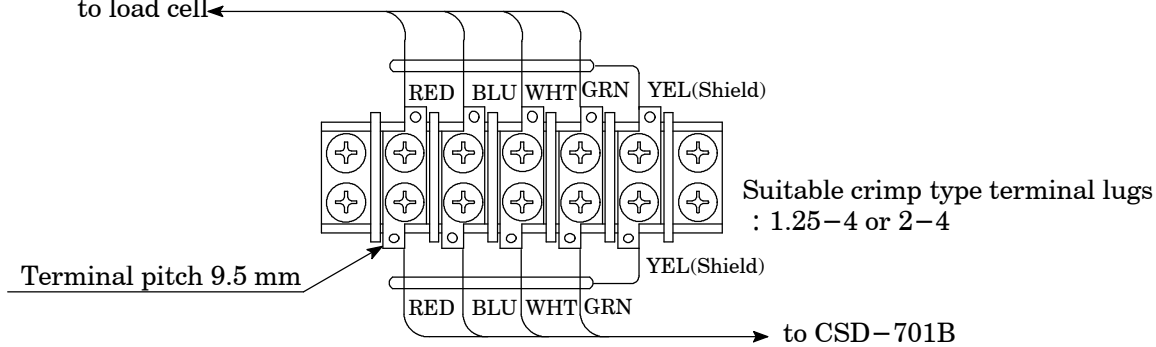



- 1 When tension is applied with the application of tension type or universal(compression/tension) type of load cell, and display of “+” direction is required, connect “Green” with Terminal No.2 and “Blue” with Terminal No.4 individually. As there is a case which standard wiring color is different, please confirm the inspection data sheet of the load cell being used.
- 2 When the length of CAB-502 is more than 30 m totally, there may have the case that the accuracy is out of warranty because the resistance of cable makes the input voltage of the instrument decreased.

③ Connection with 2 to 4 pieces of load cells, Summing type junction box(B-307) and CSD-701B.

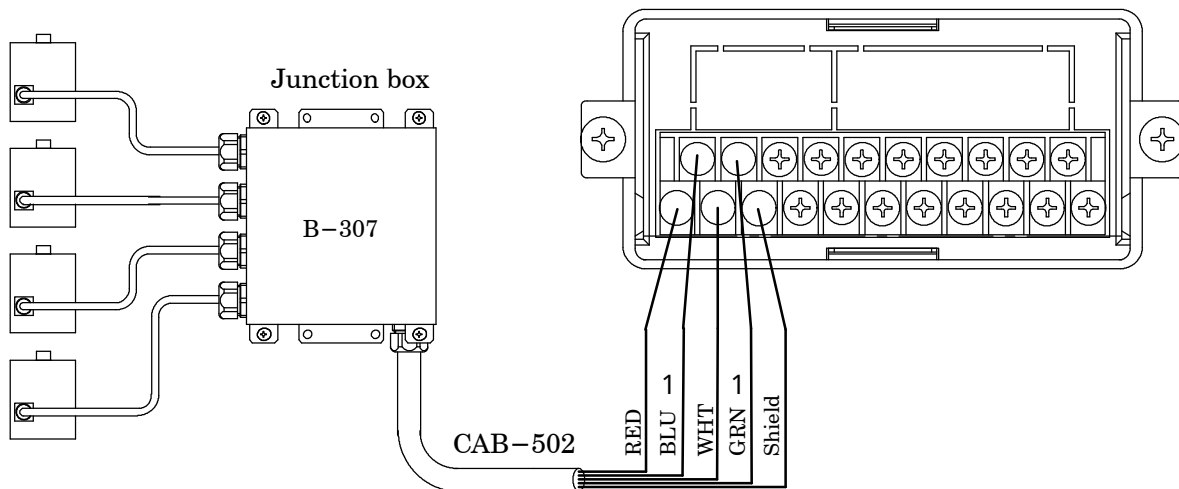

2 (Total length of CAB-502 is within 30 m)

Internal wiring diagram of B-307

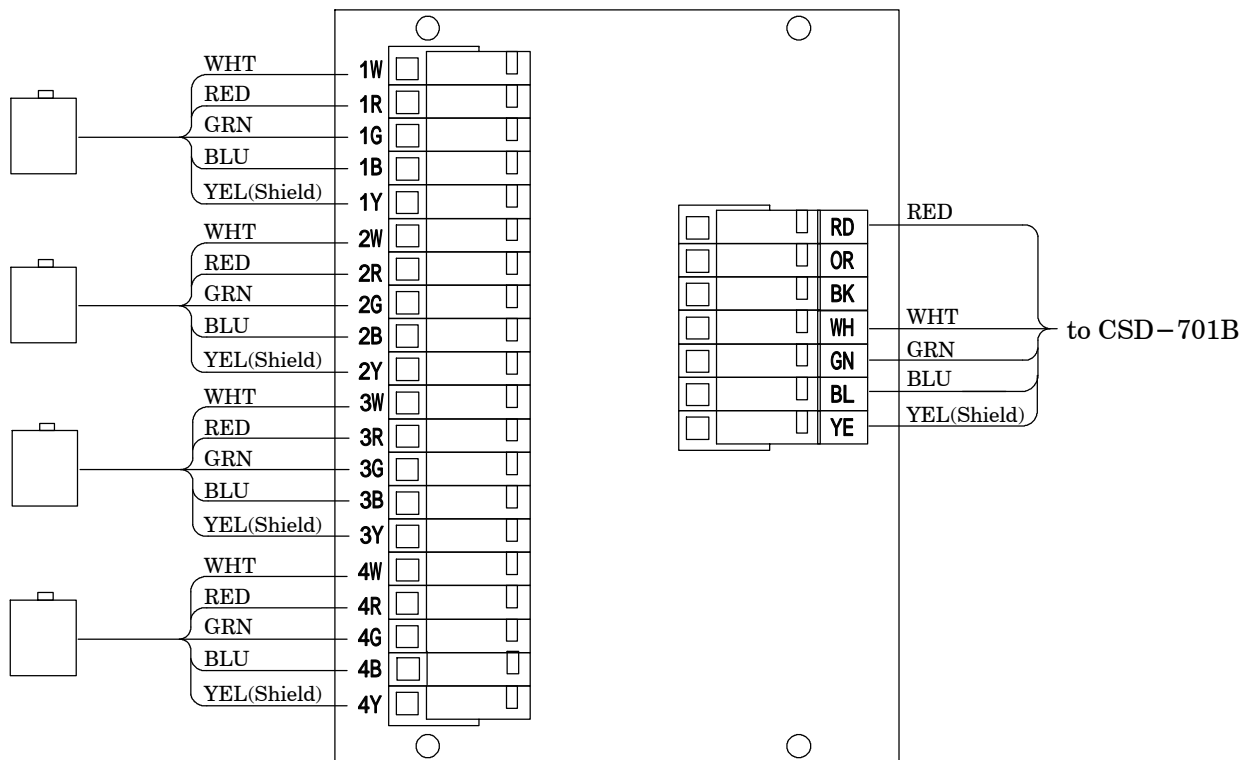



- 1 When tension is applied with the application of tension type or universal(compression/tension) type of load cell, and display of “+” direction is required, connect “Green” with Terminal No.2 and “Blue” with Terminal No.4 individually. As there is a case which standard wiring color is different, please confirm the inspection data sheet of the load cell being used.
- 2 When the length of CAB-502 is more than 30 m totally, there may have the case that the accuracy is out of warranty because the resistance of cable makes the input voltage of the instrument decreased.

④ Connection with 2 to 4 pieces of load cells, Summing type junction box(SB-310) and CSD-701B.

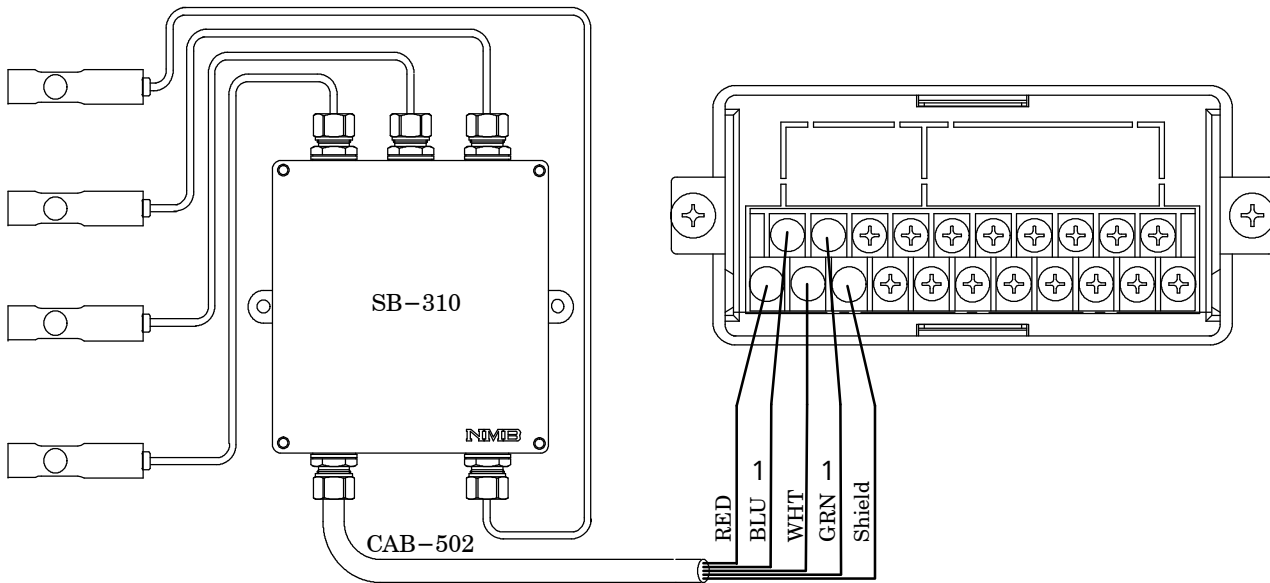

2 (Total length of CAB-502 is within 30 m)

Internal wiring diagram of SB-310

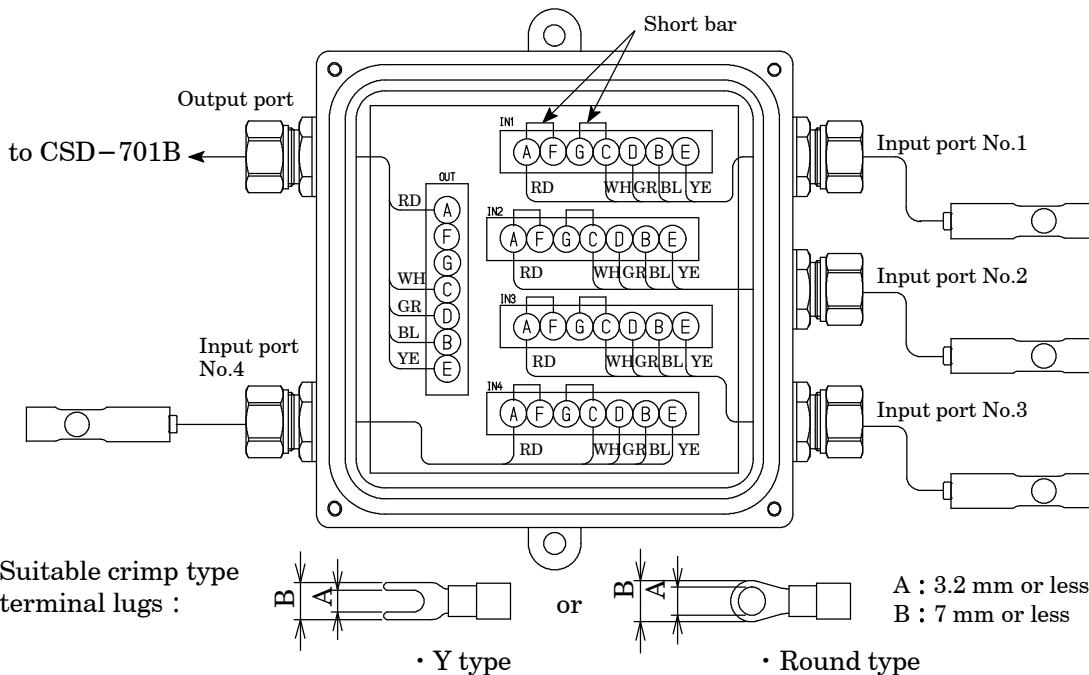

4-3-2. Connection with external control inputs

Connections with external control input “ZERO”, “HOLD”, “PEAK/TRACK” and “RESET” should be made according to the below figures by using a contact point or an open collector between the each terminal and terminal No. 8 at “COM.1”

Refer to the paragraph 7-1 for the function of each input.

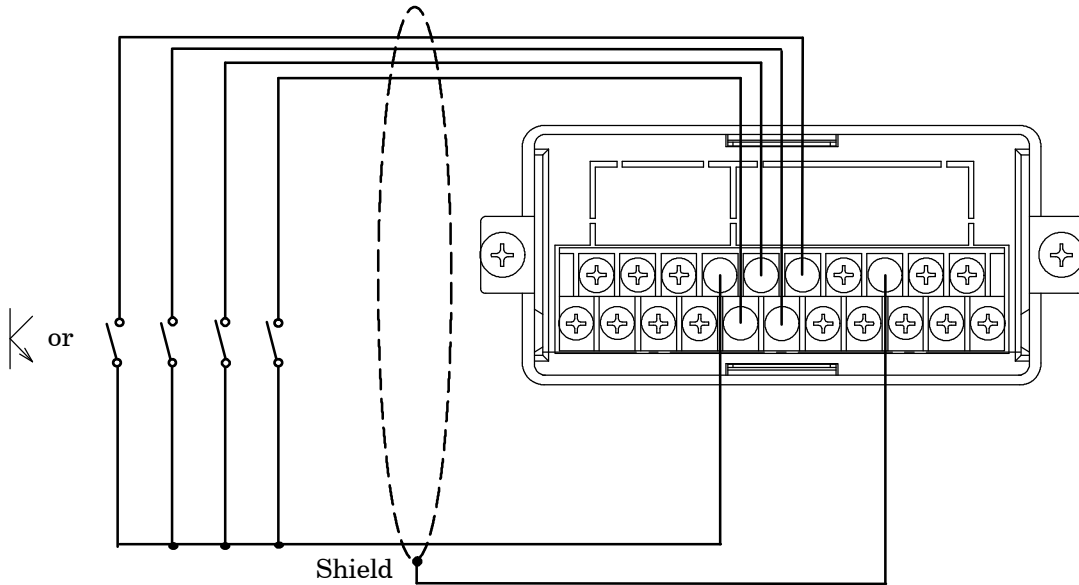

Warning

Connections with external control outputs should be made securely according to the figures. If neglected, it may cause an unexpected failure and/or malfunction to the instrument.



For the connections with external control inputs, be sure to apply shielded cable, and the shielded cable should be connected with GND terminal of the instrument.(Terminals No.16)

If not connected, it may cause malfunction due to the effects from external noises and so on.

4-3-3. Connection with contact outputs

Connections with contact outputs “S1” and “S2” and external load should be made by using each terminal and terminal No. 13 at “COM.2”.

At the same time, take care that the load should not exceed the rated load of contact output.

Rated load of contact output	AC125 V	0.1 A (Resistance load)
	DC30 V	0.5 A (Resistance load)

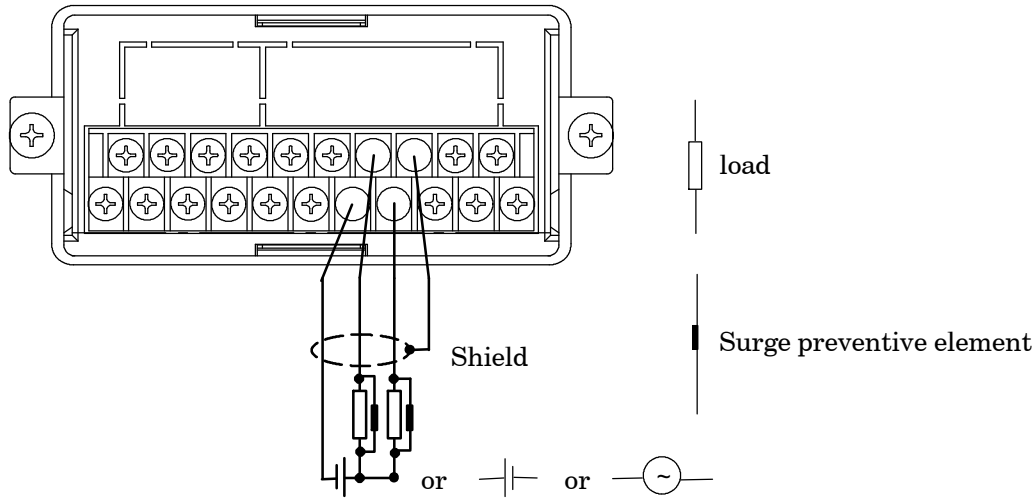

Warning

Connections with contact outputs should be made securely according to the figures and also within the rated capacity of the instrument. If neglected, it may cause an unexpected failure and/or malfunction to the instrument.

For the protection from the contact of the instrument, connect the surge preventive element that satisfies the characteristics of external load to connect. If neglected, it may cause unexpected failure and/or malfunction due to the effects from damage/melt down of the contact and so on.



For the connections with contact outputs, be sure to apply shielded cable, and the shielded cable should be connected with GND terminal of the instrument.(Terminal No.16)

If not connected, it may cause malfunction due to the effects from external noises and so on.

4-3-4. Connection with the power supply and the earth

Connections with the power supply and the earth should be made as the following figure. Grounding should be the D class with single earth.

Power supply voltage	AC100 V to AC240 V (Allowable variable range : AC85 V to AC264 V)
Frequency for power supply	50/60 Hz
Power consumption	Approx.11 VA at maximum. (at AC100 V)

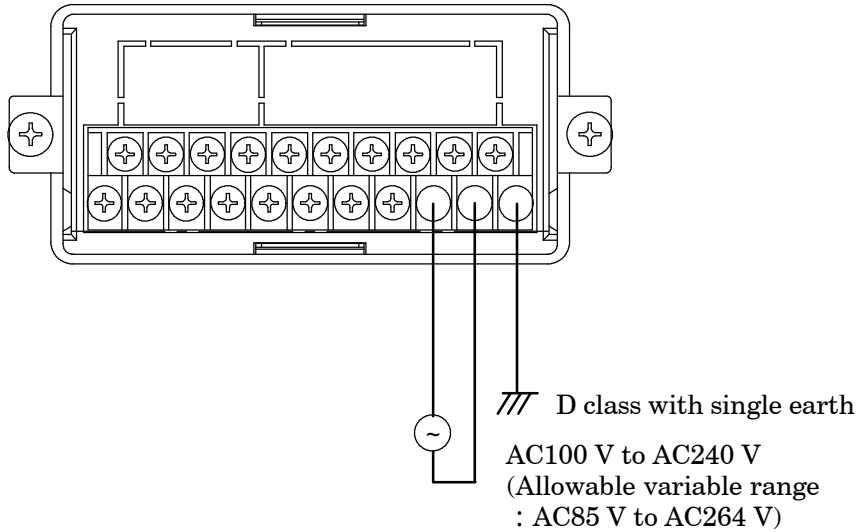

Warning

Connections with the power supply and the earth should be made securely according to the figures and also within the rated capacity of the instrument. If neglected, it may cause an unexpected cause of failure.



Grounding should be the D class with single earth. If neglected, it may cause an unexpected malfunction due to the effects of noise from other equipments.

4-3-5. Connection with analog outputs

(1) In case of standard instrument (voltage output)

The instrument prepares output voltage for analog outputs as a standard.
Connections with voltage output should be made as the following figure.

Voltage output	DC0 V to 5 V	
Over-range	At “ - OL” display	Approx. - 1.25 V
	At “OL” display	Approx. 6.25 V
Load resistance	5 k or more	

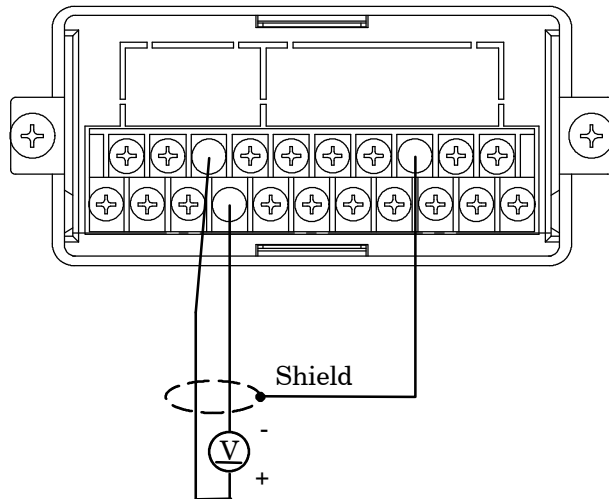

Warning

Connections with voltage outputs should be made securely according to the figures and also within specified load resistance. If neglected, it may cause an unexpected failure and/or malfunction to the instrument.



For the connections with voltage outputs, be sure to apply shielded cable, and the shielded cable should be connected with the F.G. terminal of the instrument(Terminal No.16).

If not connected, it may cause malfunction due to the effects from external noises and so on.

(2) In case of option (current output)

Connections with current output should be made as the following figure.

Current output	DC4 mA to 20 mA	
Over-range	At “ - OL” display	Approx.0 mA
	At “OL” display	Approx.24 mA
Load resistance	260 or less	

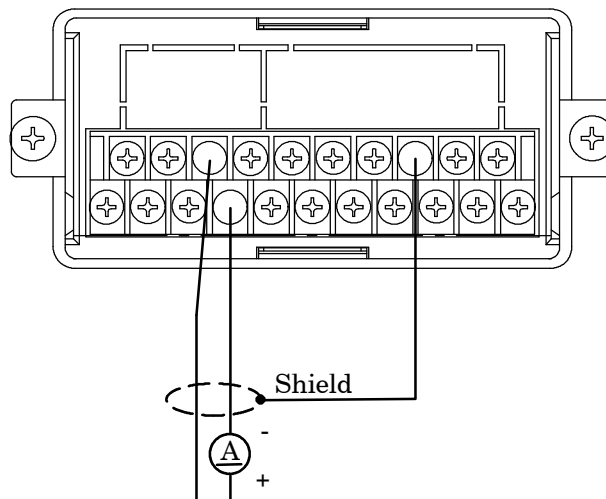

Warning

Connections with current outputs should be made securely according to the figures and also within the specified load resistance. If neglected, it may cause an unexpected failure and/or malfunction to the instrument.



For the connections with current outputs, be sure to apply shielded cable, and the shielded cable should be connected with the F.G. terminal of the instrument.(Terminal No.16)
If not connected, it may cause malfunction due to the effects from external noises and so on.

5. Calibration procedures



Warning

Before using the new instrument or after exchanging the strain gage applied transducer with a new one, be sure to make calibration. If calibration is not made, correct measured results may not be obtained, or it may cause malfunction to the instrument and it may damage the peripheral equipment. Moreover, even if calibration has made, there may occur the similar case as above when the result is not correct. So make precise calibration again.

The calibration for the instrument and “Display value at the time of minimum analog output”(F-21) and “Display value at the time of maximum analog output” (F-22) are not interlocked. In due course, make check on the setting for F-21 and F-22 securely. If neglected, correct outputs may not be obtained, or it may cause malfunction to the instrument and it may damage the peripheral equipment.

5-1. Preparations

According to the Chapter 4. Connecting method, connect the instrument and the strain gage applied transducer properly, then supply the power.

5-2. Calibration procedures

Load calibration procedures for the instrument are as follows:

- ① Calibration method to register the output (conversion with mV/V) of strain gage applied transducer at the time of maximum display (weighing capacity) after setting the load to zero (Initial load condition with tare weight).
- ② Calibration method (Automatic calibration for Zero and Span) to register the output of strain gage applied transducer (conversion with mV/V) at the time of zero load (Initial load application with tare) at the optional load condition, and also to register the output (conversion with mV/V) of strain gage applied transducer at the time of maximum display (weighing capacity).
- ③ Calibration method (Actual load calibration) to register by the reading output of strain gage applied transducer, when setting in the condition of zero load applied (Initial load application with tare) and in the condition of actual load applied individually.
- ④ Fine adjustment on Zero
- ⑤ Fine adjustment on Span
- ⑥ Calibration procedures to apply registration again for zero point only (Tare weight cancellation).



The accuracy of calibration obtained from and is 1/1 000 or so. If more than the accuracy 1/1 000 is required, make calibration of type.

In the following paragraphs, we will describe each calibration procedure by showing the examples with load cell applied.

5-2-1. Calibration method to register the output of strain gage applied transducer at the time of maximum display after setting the load to zero.



Warning

Before using a new instrument or exchanging the strain gage applied transducer for a new one, be sure to make calibration.



If calibration shall not be made, correct measured results may not be obtained nor it may cause malfunction in the instrument and there may exist damage to the peripheral equipment.

Besides, even though the calibration has been made, there may occur the similar case when the result is not correct, so make calibration again.









During the calibration is executing, be sure to set Tare weight cancellation clear, and to make cancellation (Execution of F-98) for compensated data on zero set and set the OFF position of Zero tracking (Setting "00000" on F-07 and F-08), and also set the OFF position of Peak.

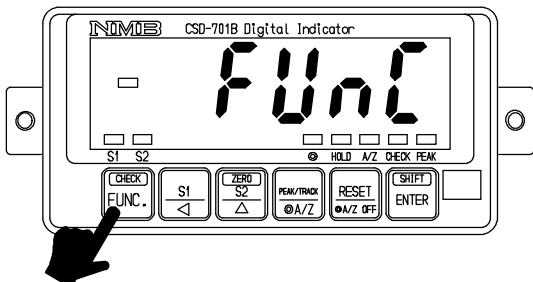

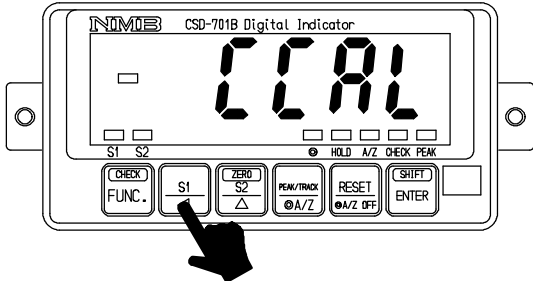
During calibration procedures, press the  key in case of interrupting the calibration is required. The calibration data will be kept as they are before entering the calibration and then returns to the Measurement mode.

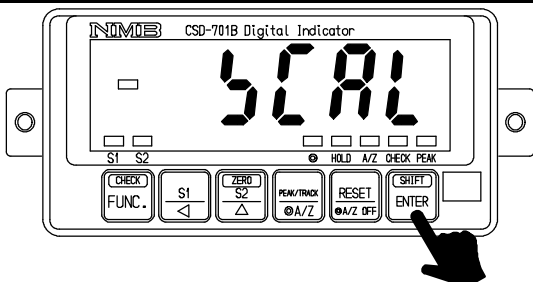
Every time the  key is pressed with the load display of "FUNC", the display will change as the following arrow marks. However, every time the  key is pressed, the display will change as the reverse direction of the following arrow marks.

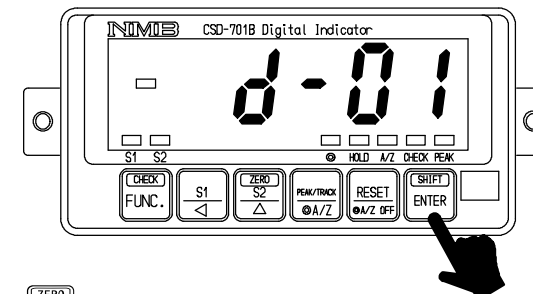
"FUNC" "CCAL" "ACAL" "LCAL" "ZERO" "SPAN"
 "TARE" "TARE" "CHEK" "MONT" "VCAL" "VADJ"
 "FUNC" "CCAL" (Hereinafter, it will repeat.)

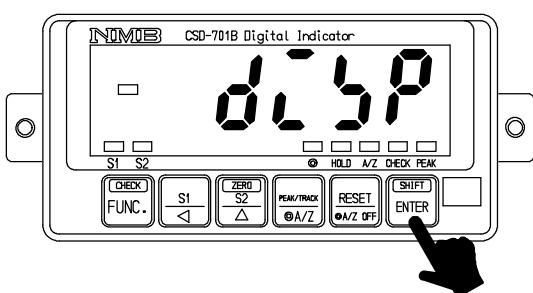
Procedures		
1	<p>Press the  key for approx. one second. The load display will show "FUNC".</p>	
2	<p>Press the  key once. The load display will show "CCAL".</p>	
3	<p>Press the  key. "CCAL" mode can be entered, then the load display will show "SCAL".</p>	
4	<p>Press the  key. The load display shows "D-01" and it will flash on and off. When the calibration has completed already, the set value of minimum scale registered at that time will be displayed. Set the minimum scale with the right keys. Setting value for the minimum scale will be 4 (four) as follows: 1, 2, 5, 10</p>	 <p> key : Set value inclement key</p>
5	<p>Press the  key. The load display will show "DISP".</p>	

Procedures

6

Press the  key.
 The load display will show “2000”, and the digit of minimum display will flash on and off.
 When the calibration has completed already, the registered value of maximum display at that time will be displayed.



By the setting of minimum scale, the digit of minimum display that flashes on and off will be as follows :

The minimum scale	1, 2, 5	10 ⁰ digit
The minimum scale	10	10 ¹ digit

Set the maximum display value with the right keys. Setting range for the maximum display value will be (the minimum scale × 100) ~ 99 990.
 In order to make effective use of the performance, set within the following ranges.
 When setting is made over the range as below, there may have a possibility of unstable display and so on.

Setting range for the maximum display value	The minimum scale
100 ~ 10 000	1
200 ~ 20 000	2
500 ~ 50 000	5
1 000 ~ 99 990	10





It can be increased continuously by the continuity press of the key.

7

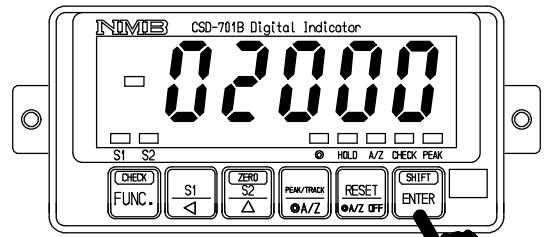
Press the  key.
 The load display will show “S MV”.



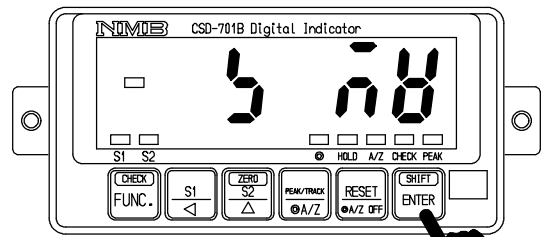

-  key : Set value carry key
-  key : Set value inclement key
-  key : Set value initialization key



Procedures



8

Press the  key.
 The load display will show “0.5000”, and the digit of 10⁰ will flash on and off.
 In case that calibration has completed already, the registered output value of load cell at that time will be displayed.
 Set the given value with the right keys, which is subtracted the output value of load cell at the time of initial load application from the output value of load cell corresponding to the maximum display value set in the step 6.

 Though the number of digits has not prepared in the “Inspection data” for load cell so many as shown in the right figure, extra digits are necessary for the compensation with the standard point at internal of the instrument.
 In case of actual setting, insert “0”, into the extra digits.
 As for the value for extra digit, when tare compensation and fine adjustment on load are applied, it will be rewritten as a compensated value automatically.
 Setting range for the output of load cell is from 0.400 0 mV/V to 3.100 0 mV/V.

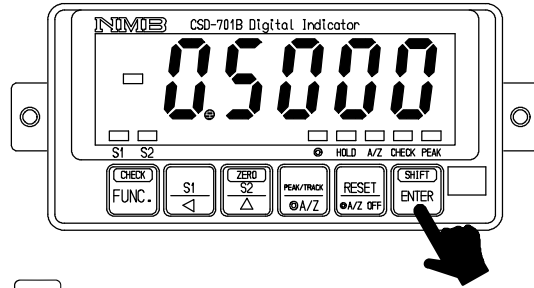
 It can be increased continuously by the continuity press of the key.





-  key : Set value carry key
-  key : Set value inclement key
-  key : Set value initialization key

9

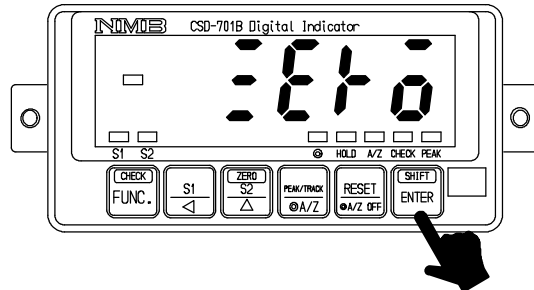
Press the  key.
 The load display will show “ZERO”.
 Here, set the instrument with initial load application.



Procedures							
<p>10</p>	<p>Press the  key. The load display will show “ZERO” with lighting display on and off, then zero adjustment can be started.</p> <div data-bbox="231 465 842 689" style="border: 1px solid black; padding: 5px;"> <p> Warning : At the same time, take care not to apply load variation due to vibration and so on. When load variation is applied, there will be possibilities that zero point is unstable, and precise reading of zero will not be obtained.</p> </div> <p>After completed, the load display will become “END”.</p> <p>However, when the initial load is not entered within the range from - 0.3 mV/V to 2.4 mV/V, the error code shown in the right figure will show for about 2 seconds, then load display will show “ZERO” and return to step 9.</p> <table style="margin-left: 40px;"> <tr> <td>TE-L</td> <td>: Zero point</td> <td>- OVER</td> </tr> <tr> <td>TE-H</td> <td>: Zero point</td> <td>+ OVER</td> </tr> </table>	TE-L	: Zero point	- OVER	TE-H	: Zero point	+ OVER
TE-L	: Zero point	- OVER					
TE-H	: Zero point	+ OVER					
<p>11</p>	<p>Press the  key. After “CCAL” mode is over, the load display will show the present load.</p>						

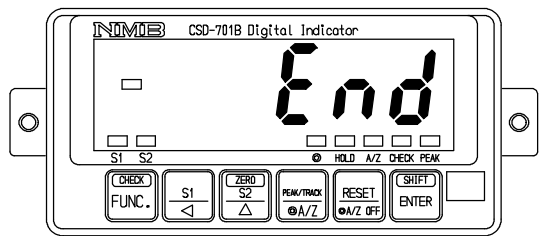
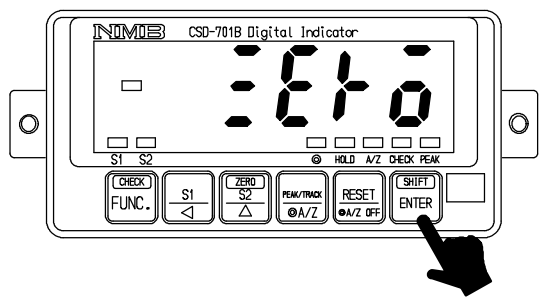

Error Code



Error Code

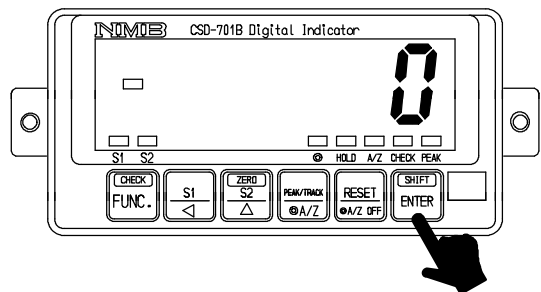

5-2-2. Calibration procedures to register the output of strain gage applied transducer at the time of zero and the maximum display

(1) Procedure by key operation



Warning

Before using a new instrument or exchanging the strain gage applied transducer for a new one, be sure to make calibration.

If calibration shall not be made, correct measured results may not be obtained nor may cause malfunction in the instrument and there may exist damage in peripheral equipments.



Besides, even though calibration has been made, there may occur the similar case when the result is not correct, so make calibration again.

During the calibration is executing, be sure to set Tare weight cancellation clear, and to make cancellation (Execution of F-98) for compensated data on zero set and set the OFF position of Zero tracking (Setting "00000" on F-07 and F-08), and also set the OFF position of Peak.









If neglected, correct measured results may not be obtained.

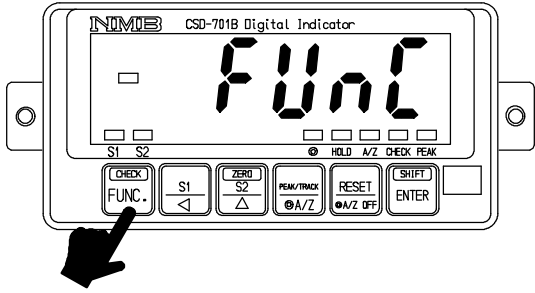

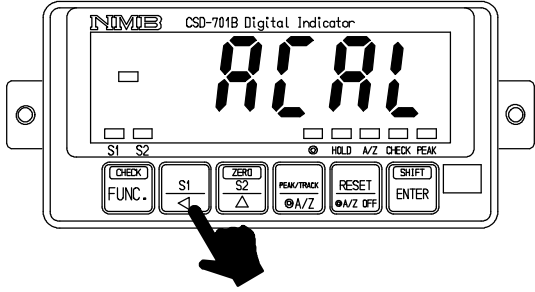
During calibration procedures, press the  key in case of interrupting the calibration is required. The calibration data will be kept as they are before entering the calibration and then returns to the Measurement mode.

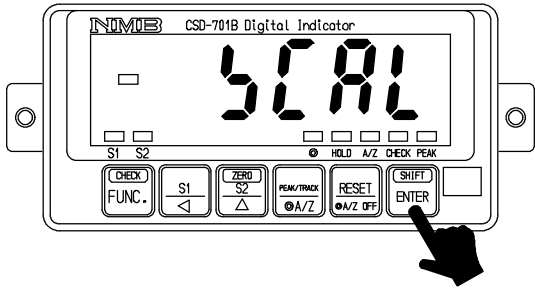
Every time the  key is pressed with the load display of "FUNC", the display will change as the following arrow marks. However, every time the  is pressed, the display will change as the reverse direction of the following arrow marks.

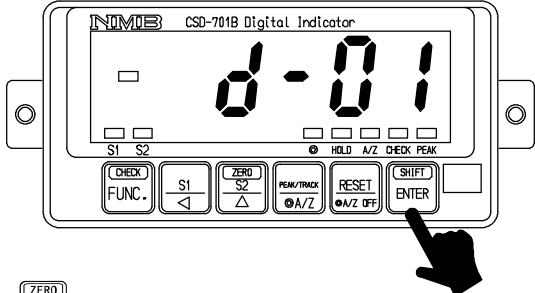
"FUNC" "CCAL" "ACAL" "LCAL" "ZERO" "SPAN"
"TARE" "CHEK" "MONT" "VCAL" "VADJ" "FUNC"
"CCAL" ····· (Hereinafter, it will repeat.)

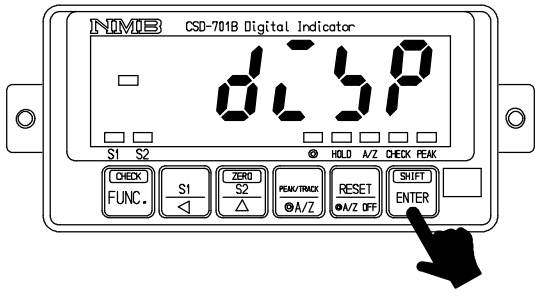
Procedures		
1	<p>Press the  key for about one second The load display will show "FUNC".</p>	
2	<p>Press the  key twice. It will make the load display proceed as "FUNC" "CCAL" "ACAL".</p>	
3	<p>Press the  key. "ACAL" mode can be entered, then the load display will show "SCAL".</p>	
4	<p>Press the  key. The load display shows "D-01". When the calibration has completed already, the set value of minimum scale which has registered at that time will be displayed. Set the minimum scale with the right keys. Setting value for the minimum scale will be 4 (four) as follows : 1, 2, 5, 10</p>	 <p> key : Set value inclement key</p>
5	<p>Press the  key. The load display will show "DISP".</p>	

Procedures

6

Press the  key.
 The load display shows “2000” and the minimum display digit will flash on and off.
 When the calibration has completed already, the maximum display value which has registered at that time will be displayed.

 By the setting of minimum scale, the digit of minimum display that flashes on and off will be as follows :

The minimum scale	1,2,5	10 ⁰ digit
The minimum scale	10	10 ¹ digit

Set the maximum display value with the right keys. Setting range for the maximum display value will be (the minimum scale × 100) ~ 99 990.
 In order to make effective use of the performance, set within the following ranges.
 When setting is made over the range as below, there may have a possibility of unstable display and so on.

Setting range for the maximum display value	The minimum scale
100 ~ 10 000	1
200 ~ 20 000	2
500 ~ 50 000	5
1 000 ~ 99 990	10

 It can be increased continuously by the continuity press of the key.

7

Press the  key.
 The load display will show “Z MV”.

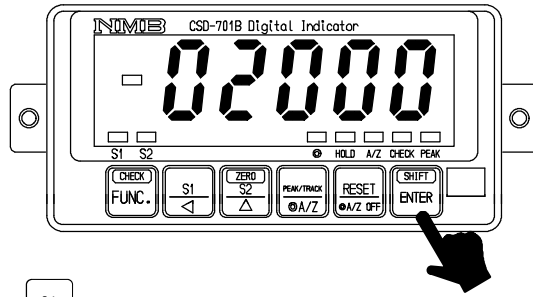





 key : Set value carry key

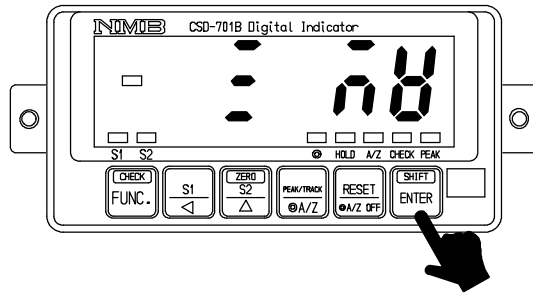

 key : Set value inclement key

 key : Set value initialization key

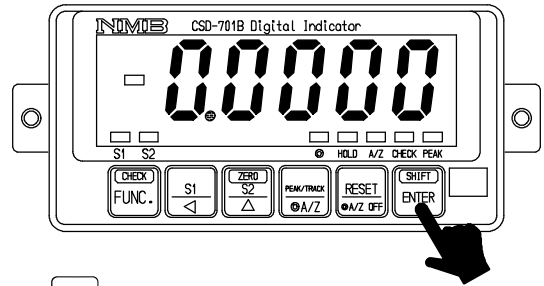

Procedures	
<p>8</p>	<p>Press the  key. The load display will show “0.0000”, and the digit of 10⁰ will flash on and off. In case that calibration has completed already, the registered output value of load cell at that time will be displayed. Set the output value for load cell with the initial load application with the right keys.</p> <div data-bbox="231 459 845 918" style="border: 1px solid black; padding: 5px;"> <p> Though the number of digits has not prepared in the "Inspection data" for load cell so many as shown in the right figure, extra digits are necessary for the compensation with the standard point at internal of the instrument. In case of actual setting, insert "0", into the extra digits. As for the value for extra digit, when tare compensation and fine adjustment on load are applied, it will be rewritten as a compensated value automatically. Setting range for the output of load cell is from - 0.3 mV/V to 2.400 0 mV/V.</p> </div> <div data-bbox="231 940 845 1041" style="border: 1px solid black; padding: 5px;"> <p> It can be increased continuously by the continuity press of the key.</p> </div>
<p>9</p>	<p>Press the  key. The load display will show “S MV”.</p>



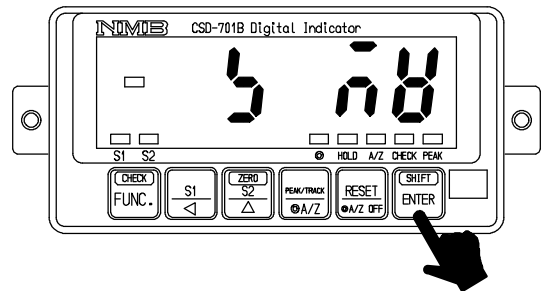

-  key : Set value carry key
-  key : Set value inclement key
-  key : Set value initialization key



Procedures



10

Press the  key.
 The load display will show “0.5000” and the digit at 10⁰ will flash on and off.
 In case that calibration has completed already, the registered output value of load cell at that time will be displayed.
 The output value of the load cell which corresponds to the maximum indicated value set according to the procedure 8 is set with the right keys.

 The set value to be set here should be 0.4 mV/V or more than the set value in the step 8.
 Though the number of digits has not prepared in the Inspection data for load cell as many as the digits in the right figure, extra digits are necessary for the compensation for the internal standard point of the instrument.
 In case of actual setting, insert “0” into the extra digits.
 As for the value of extra digits, when tare compensation and fine adjustment on load are applied, it will be written as a compensated value automatically.

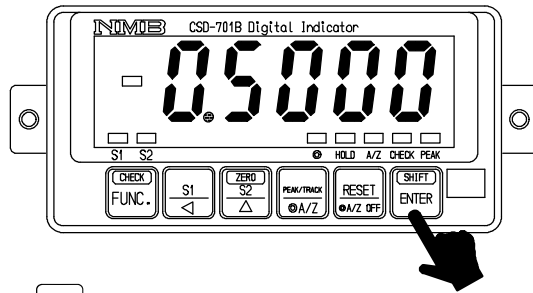
 It can be increased continuously by the continuity press of the key.



-  key : Set value carry key
-  key : Set value increment key
-  key : Set value initialization key

11

Press the  key.
 The load display will show the “END”.

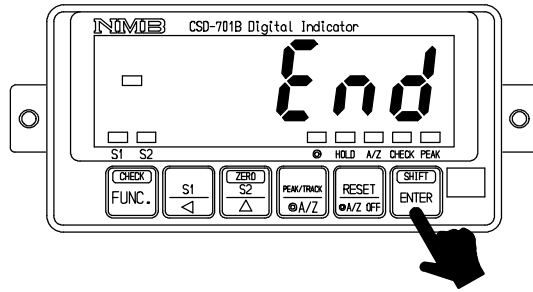

12

Press the  key.
 After “ACAL” mode is over, the load display will show the present load.

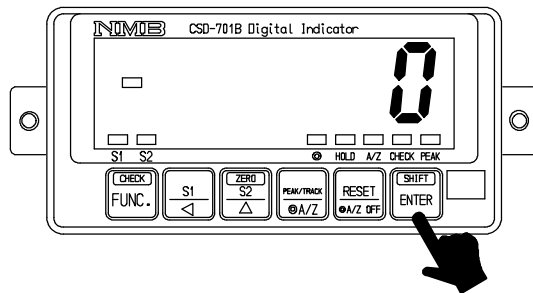

5-2-3. Calibration method to register by reading output value of strain gage applied transducer in the conditions of zero/actual load application individually.

(1) Procedures by the key operation



Warning

Before using a new instrument or exchanging the strain gage applied transducer for a new one, be sure to make calibration.



If calibration shall not be made, correct measured results may not be obtained nor may cause malfunction in the instrument and there may exist damage in peripheral equipments.

Besides, even though calibration has been made, there may occur the similar case when the result is not correct, so make calibration again.









During the calibration is executing, be sure to set Tare weight cancellation clear, and to make cancellation (Execution of F-98) for compensated data on zero set and set the OFF position of Zero tracking (Setting "00000" on F-07 and F-08), and also set the OFF position of Peak.

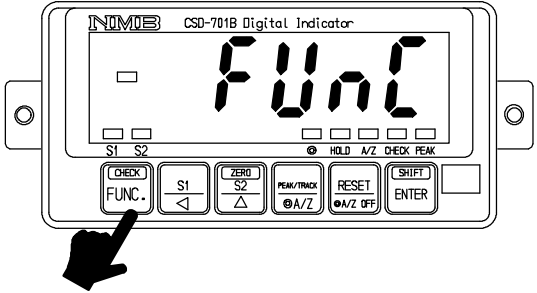

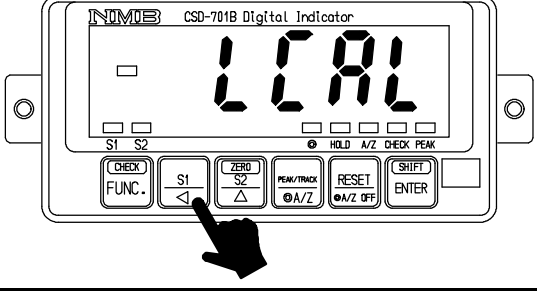
During calibration procedures, press the  key in case of interrupting the calibration is required. The calibration data will be kept as they are before entering the calibration and then returns to the Measurement mode.

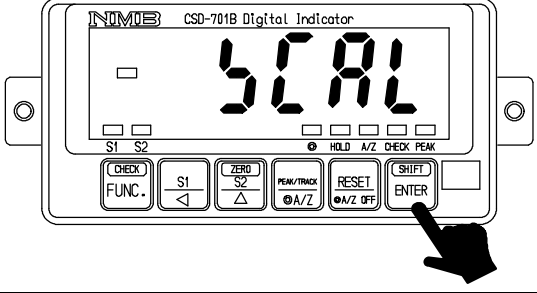
Every time the  key is pressed with the load display of "FUNC", the display will change as the following arrow marks. However, every time the  is pressed, the display will change as the reverse direction of the following arrow marks.

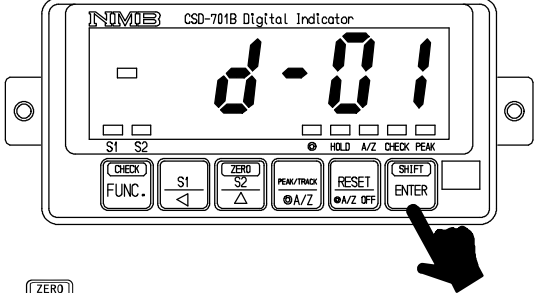
"FUNC" "CCAL" "ACAL" "LCAL" "ZERO" "SPAN"
"TARE" "CHEK" "MONT" "VCAL" "VADJ" "FUNC"
"CCAL" (Hereinafter, it will repeat.)

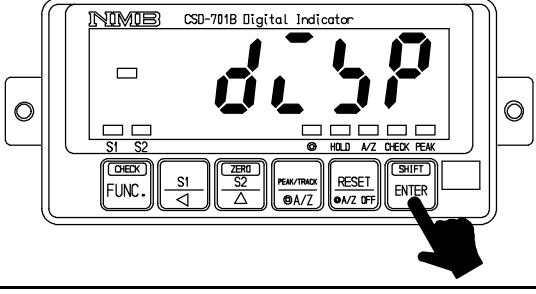
Procedures		
1	<p>Press the  key for about one second. The load display will show "FUNC".</p>	
2	<p>Press the  key three times. It will make the load display proceed as "FUNC" "CCAL" "ACAL" "LCAL".</p>	
3	<p>Press the  key. "LCAL" mode can be entered, then the load display will show "SCAL".</p>	
4	<p>Press the  key. The load display shows "D-01". When the calibration has completed already, the set value of minimum scale registered at that time will be displayed. Set the minimum scale with the right keys. Setting value for the minimum scale will be 4 (four) as follows : 1, 2, 5, 10</p>	 <p> key : Set value inclement key</p>
5	<p>Press the  key. The load display will show "DISP".</p>	

Procedures

6

Press the  key.
 The load display shows “2000” and the minimum display digit will flash on and off.
 When the calibration has completed already, the maximum display value which has registered at that time will be displayed.

 By the setting of minimum scale, the digit of minimum display that flashes on and off will be as follows :



The minimum scale	1,2,5	10 ⁰ digit
The minimum scale	10	10 ¹ digit

Set the maximum display value with the right keys. Setting range for the maximum display value will be (the minimum scale × 100) ~ 99 990.
 In order to make effective use of the performance, set within the following ranges.
 When setting is made over the range as below, there may have a possibility of unstable display and so on.

Setting range for the maximum display value	The minimum scale
100 ~ 10 000	1
200 ~ 20 000	2
500 ~ 50 000	5
1 000 ~ 99 990	10

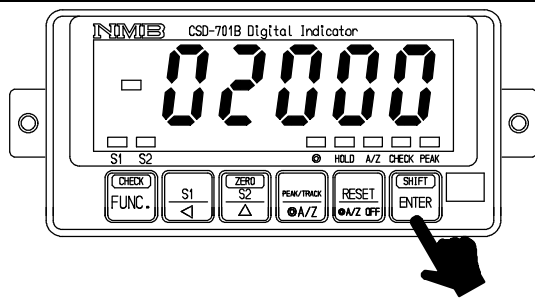
 It can be increased continuously by the continuity press of the key.



-  key : Set value carry key
-  key : Set value inclement key
-  key : Set value initialization key

7

Press the  key.
 The load display will show “LOAD”.

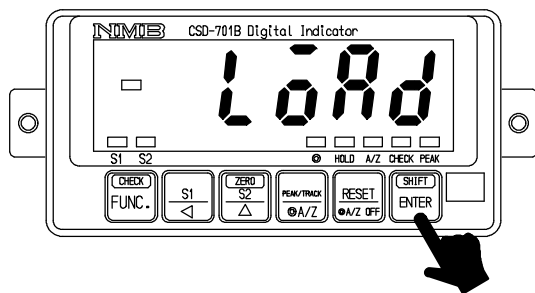

Procedures

8

Press the  key.
 The load display will show “2000”, and the digit of 10⁰ will flash on and off.
 In case that calibration has completed already, the registered output value of load cell at that time will be displayed.

 By the setting of minimum scale, the digit of minimum display that flashes on and off will be as follows :

The minimum scale	1,2,5	10 ⁰ digit
The minimum scale	10	10 ¹ digit

Set the actual load value going to apply on the load cell with the right keys.
 The load value applied on the load cell should be less than the maximum display value set in the step 6 and should be the maximum load that can apply on the load cell with the range of (the minimum scale × 100) ~ 99 999 as well.

 It can be increased continuously by the continuity press of the key.

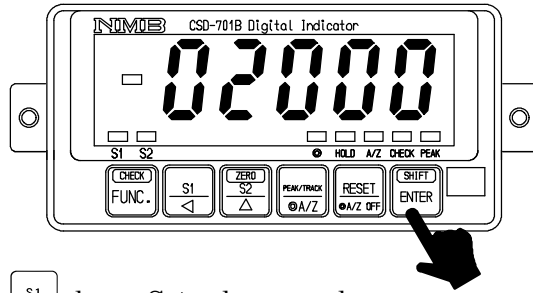

 key : Set value carry key





 key : Set value inclement key

 key : Set value initialization key

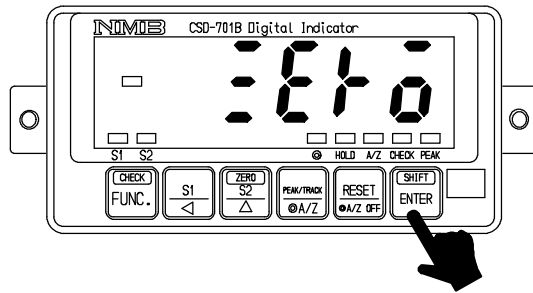
9

Press the  key.
 The load display will show “ZERO”.
 Here, set the initial load application.

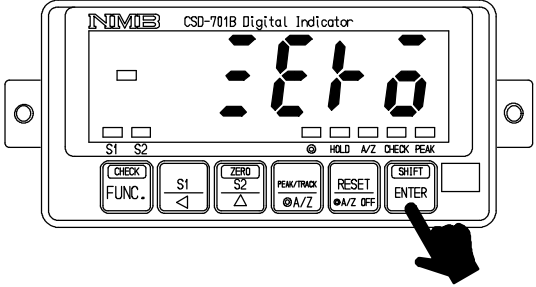
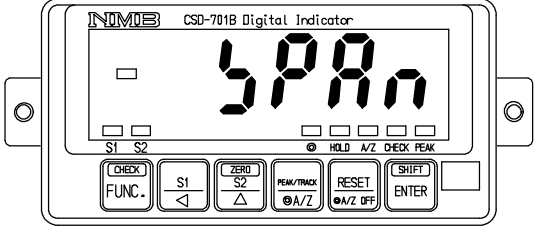

Procedures		
<p>10</p>	<p>Press the  key. The “ZERO” on load display will flash on and off, and zero adjustment can be started.</p> <div style="border: 1px solid black; padding: 5px; margin: 10px 0;"> <p> Warning : Take care not to apply load variations due to vibrations and so on. If load variation is applied, the zero point will not be stabilized, in due course there is a possibility that correct reading of zero won't be obtained.</p> </div> <p>When completed, the display on the load display will show “SPAN”.</p> <p>However, when the initial load is not entered the range of - 0.3 mV/V to 2.4 mV/V, the right Error code will be shown for about 2 seconds, then the display on the load display section will be shown as “ZERO”, and then the procedure 9 can be entered.</p> <p>TE-L : Zero point - OVER TE-H : Zero point + OVER</p>	  <p>Error code</p>  <p>Error code</p> 
<p>11</p>	<p>Apply the same load on the load cell as set in the step 8.</p>	

Procedures

12

Press the  key.
The "SPAN" on the load display will flash on and off, and span adjustment can be started.

 **Warning** : Take care not to apply load variations due to vibrations and so on. If load variation is applied, the span will not be stabilized, in due course there is a possibility that correct reading of span won't be obtained.

When completed, the display on the load display will show "END".
However, when the value corresponding to the maximum display value does not satisfy the range from 0.4 mV/V to 3.1 mV/V, the right Error code will light up for about 2 seconds, then the display on the load display section will show "SPAN", and then returns to the step 10.

SP-L : Span - Over
SP-H : Span + Over

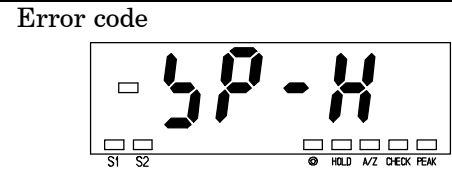
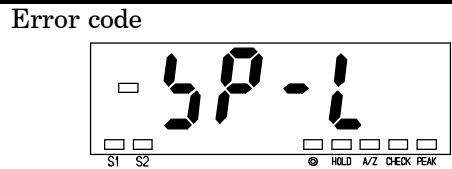
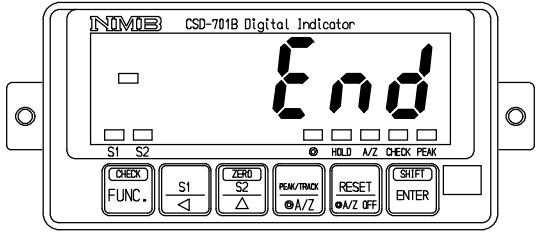
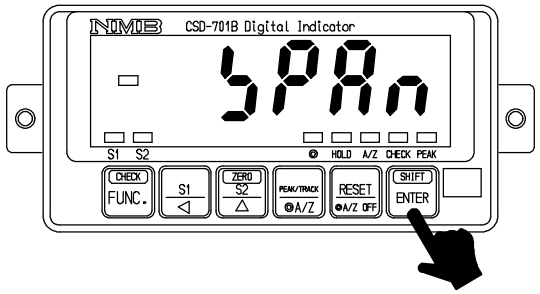

13

Press the  key.
After "LCAL" mode is over, the load display will show the present load.

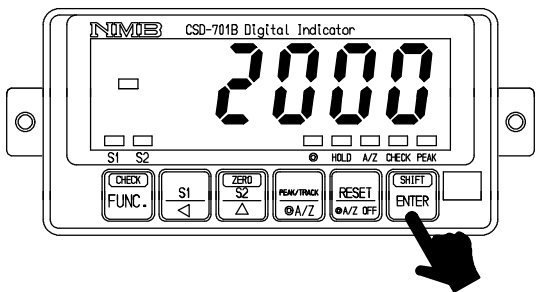

5-2-4. Zero fine adjustment



(1) Procedures by key operation





During the Tare weight cancellation(A/Z) or Zero set is executed, and also during effective for Zero tracking and Peak ON, Zero fine adjustment mode can't be entered into. (Displays ER-5.)







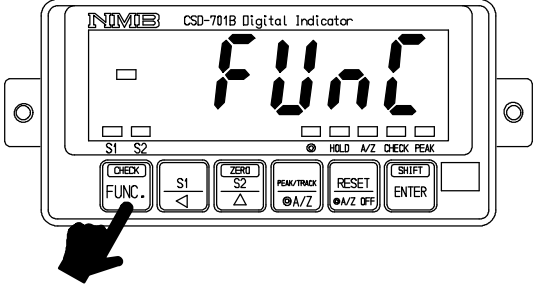

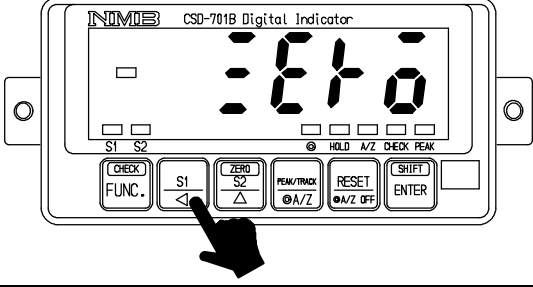
The Zero fine adjustment can be entered after Tare weight cancellation clear(A/Z OFF), cancellation of the Compensated data at Zero set (Execution of F-98), set OFF the Zero tacking (Set the F-08 and F-09 to "00000".) and set the Peak OFF.

During the calibration procedure, press the  key to interrupt the calibration. The calibration data will keep the same condition as it is entered before, then returns to the Measurement mode.

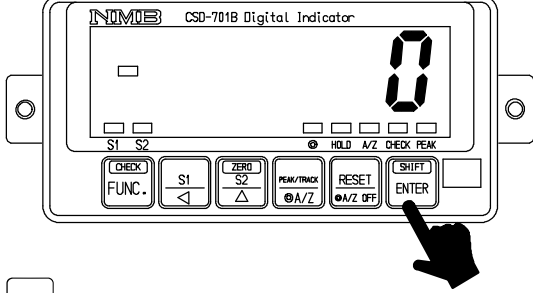
When the  key is pressed with the load display of "FUNC", the display will change as the following arrow marks indicate at every time the key is pressed. However, every time the  is pressed, the display will change as the reverse direction of the following arrow marks.

"FUNC" "CCAL" "ACAL" "LCAL" "ZERO" "SPAN"
 "TARE" "CHEK" "MONT" "VCAL" "VADJ" "FUNC"
 "CCAL" (Hereinafter, it will repeat.)

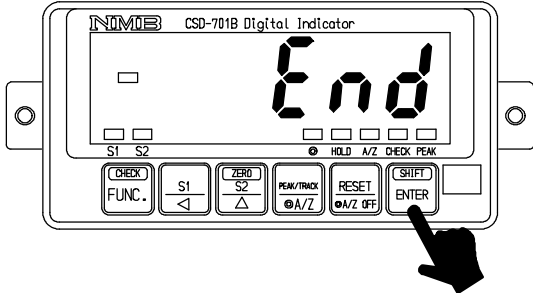
	Procedures	
1	Press the  key for about one second. The load display will show "FUNC".	
2	Press the  key four times. It will make the load display proceeded as "FUNC" "CCAL" "ACAL" "LCAL" "ZERO". Here, set the initial load application.	

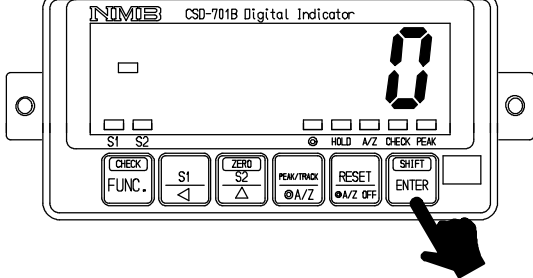
Procedures		
3	<p>Press the  key.</p> <p>Zero fine adjustment mode can be entered, then the display on load display will show the present load value and lights on and off. At the same time, set the present load value to “0” with the right keys.</p> <div data-bbox="119 376 734 492" style="border: 1px solid black; padding: 5px;"> <p> It can be increased continuously by the continuity press of the key.</p> </div> <div data-bbox="119 515 734 705" style="border: 1px solid black; padding: 5px;"> <p> The variation of load value for one push of the right key is less than 1 digit of display. Therefore, a few pushes of these keys are required to get the change of 1 digit of display value.</p> </div>	 <p> key : Zero fine adjustment display decreasing key</p> <p> key : Zero fine adjustment display increasing key</p>
4	<p>Press the  key.</p> <p>The indication of load display will show “END”.</p>	
5	<p>Press the  key.</p> <p>After quitting from zero fine adjustment mode, the load display will show the present load value.</p>	

5-2-5. Span fine adjustment



(1) Procedures by key operation





During the Tare weight cancellation(A/Z) or Zero set is executed, and also during effective for Zero tracking and Peak ON, Span fine adjustment mode can't be entered into. (Displays ER-5.)

The Span fine adjustment can be entered after Tare weight cancellation clear(A/Z OFF), cancellation of the Compensated data at Zero set (Execution of F-98), set OFF the Zero tacking (Set the F-08 and F-09 to "00000".) and set the Peak OFF.





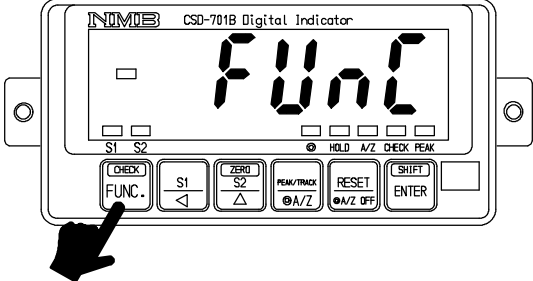

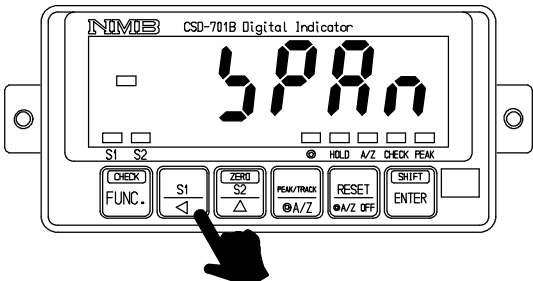

During the calibration procedure, press  key to interrupt the calibration. The calibration data will keep the same condition as it is entered before, then returns to the Measurement mode.

When the  key is pressed with the load display of "FUNC", the display will change as the following arrow marks indicate at every time the key is pressed. However, every time the  is pressed, the display will change as the reverse direction of the following arrow marks.

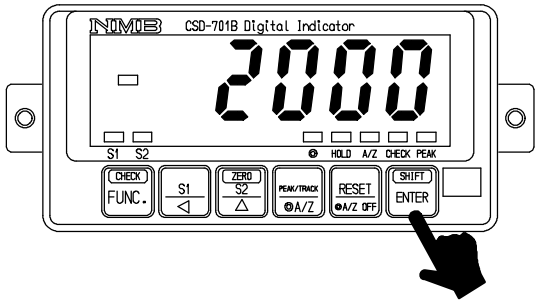
"FUNC" "CCAL" "ACAL" "LCAL" "ZERO" "SPAN"
 "TARE" "CHEK" "MONT" "VCAL" "VADJ" "FUNC"
 "CCAL" (Hereinafter, it will repeat.)

	Procedures	
1	Press the  key for about one second. The load display will show "FUNC".	
2	Press the  key five times. It will make the load display proceeded as "FUNC" "CCAL" "ACAL" "LCAL" "ZERO" "SPAN". Please give the maximum load which can be applied to the load cell here below the maximum indicated value.	

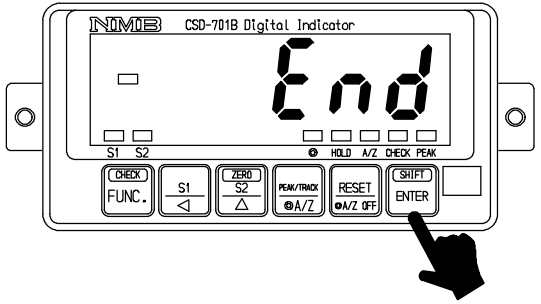
Procedures

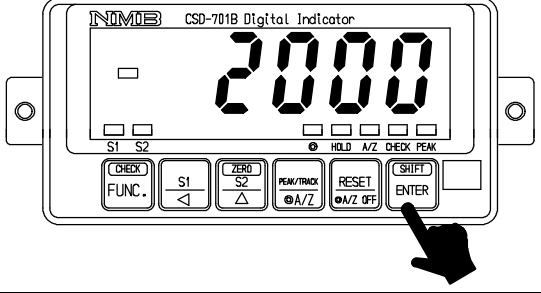
<p>3</p>	<p>Press the  key.</p> <p>Span fine adjustment mode can be entered, then the display on load display will show the present load value and lights on and off. At the same time, adjust the present load value to be the same load applied on the load cell with the right keys.</p> <div style="border: 1px solid black; padding: 5px; margin: 5px 0;"> <p> It can be increased continuously by the continuity press of the key.</p> </div> <div style="border: 1px solid black; padding: 5px; margin: 5px 0;"> <p> The variation of load value for one push of the right key is less than 1 digit of display. Therefore, a few pushes of these keys are required to get the change of 1 digit of display value.</p> </div>	 <p> key : Span fine adjustment display decreasing key</p> <p> key : Span fine adjustment display increasing key</p>
<p>4</p>	<p>Press the  key.</p> <p>The indication of load display will show “END”.</p>	
<p>5</p>	<p>Press the  key.</p> <p>After quitting from zero Span fine adjustment mode, the load display will show the present load value.</p>	

5-2-6. Calibration procedure to apply registration again for zero point only

(1) Procedures by key operation





Warning



During the execution of calibration, be sure to set the Tare weight cancellation clear, cancellation of the Compensated data at Zero set (Execution of F-98), and set OFF the Zero tacking (Set the F-08 and F-09 to "00000".) and set the Peak OFF.





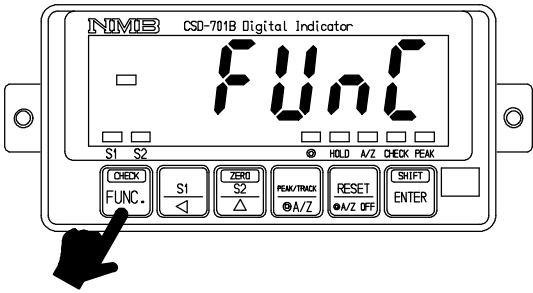

During the calibration procedure, press the  key to interrupt the calibration. The calibration data will keep the same condition as it is entered before, then returns to the Measurement mode.

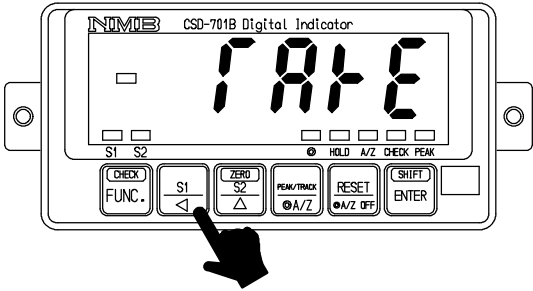
When the  key is pressed with the load display of "FUNC", the display will change as the following arrow marks indicate at every time the key is pressed. However, every time the  is pressed, the display will change as the reverse direction of the following arrow marks.

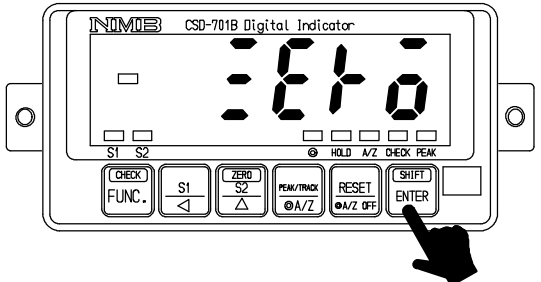
"FUNC" "CCAL" "ACAL" "LCAL" "ZERO" "SPAN"
 "TARE" "CHEK" "MONT" "VCAL" "VADJ" "FUNC"
 "CCAL" (Hereinafter, it will repeat.)

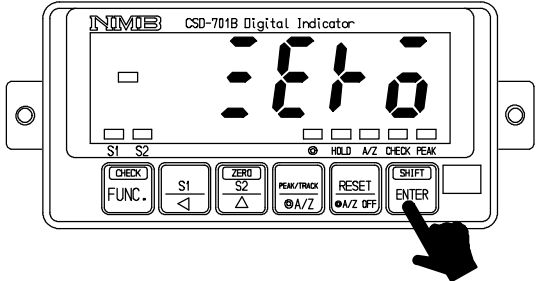
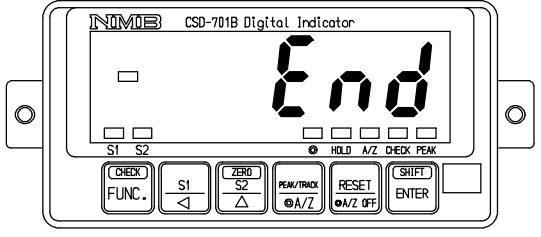
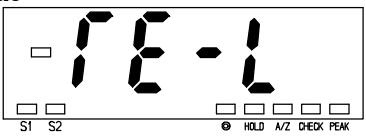
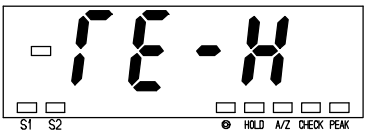
Procedures	
1	<p>Press the  key for about one second. The load display will show "FUNC".</p>
	
2	<p>Press the  key six times. It will make the load display proceeded as "FUNC" "CCAL" "ACAL" "LCAL" "ZERO" "SPAN" "TARE". Here, set the initial load application.</p>
	

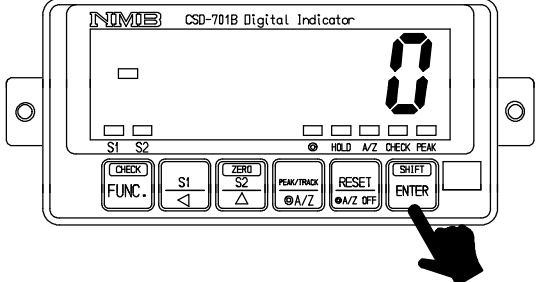
Procedures		
3	<p>Press the  key. The "TARE" mode can be entered. The display on the load display section will show "ZERO".</p>	
4	<p>Press the  key. The display of "ZERO" on the load display section will flash on and off, and Tare weight cancellation will be entered.</p> <div style="border: 1px solid black; padding: 5px; margin: 10px 0;"> <p> Warning : At the same time, care should be taken not to apply load variation due to vibration and so on. If load variation is applied, zero point becomes unstable, so there is a possibility that correct zero can't be read.</p> </div> <p>When completed, the indication of load display will show "END". However, when the initial load isn't entered within the range of - 0.3 mV/V and 2.4 mV/V, the error code in the right will be shown for about 2 seconds, then the display on the load display will show "TARE", and returns to the step 2.</p> <p>TE-L : Zero point - OVER TE-H : Zero point + OVER</p>	  <p>Error code</p>  <p>Error code</p> 
5	<p>Press the  key. After quitting from the "TARE" mode, the load display will show the present load value.</p>	

5-3. Selection of calibration methods on each condition

The instrument prepares calibration methods shown in the paragraph in ****タグなし****. Calibration procedures, we'll explain some conditions to execute actual calibration here.

(1) When executing calibration on the new instrument.

(In case that Combined Inspection at Minebea has not executed.)

- When load condition and output condition of load cell are clarified.
(Required accuracy is less than 1/1 000 or so.)
Proceed to the paragraph 5-3-1(1)
- When load condition and output condition of load cell are clarified.
(Required accuracy is more than 1/1 000 or so.)
Proceed to the paragraph 5-3-1(2)
- When load condition is clarified, but output condition of load cell is unclear.
Proceed to the paragraph 5-3-1(3)
- When exchanging with existing CSD-701B is required.
Proceed to the paragraph 5-3-1(4)

(2) When making calibration again.

- When calibration only for tare weight is required.
(In case that the combined Inspection at Minebea has already executed, and the calibration only for tare weight is required.)
- When fine adjustment on zero and span is required.

5-3-1. In case of executing the calibration on the instrument newly.

When the new instrument is purchased or reuse is desired with the new specific conditions, execute the calibration with whichever procedure as follows :

- (1) When the load condition and the output condition of load cell are clarified.
(In case of desired accuracy is less than 1/1000 or so.)



Warning

The calibration accuracy obtained in this procedure is less than 1/1 000 or so. When precise accuracy more than 1/1 000 is necessary, make calibration with actual load according to the paragraph 5-3-1 (2).

Besides, the accuracy described here is a combined accuracy of the instrument and the strain gage applied transducer connected. If there may exist another factors of error such as mechanical elements and so on, it will become out of warranty, so care should be taken fully.

The rated output value for load cell applicable by the calculation should be assumed as the value described on the "Inspection data" individually.

5-2-1 For example, we will show the calibration procedures as follows, that is, 3 points of load cells with 3 mV/V of rated output and 5 t of rated capacity.

Tare weight	1.5 t
Weighing capacity	5 t
Maximum display	5 000

- ① Calculate the output of load cell at maximum display from the above conditions. Check that the calculated value should be within the range from 0.4 mV/V to 3.1 mV/V. If the value is out of the range, calibration can't be executed.

(Output of load cell at maximum display)

$$\begin{aligned}
 &= \frac{(\text{Rated output}) + (\text{Rated output}) + (\text{Rated output})}{\text{Number of load cells}} \times \frac{\text{Weighing capacity}}{(\text{No. of load cells}) \times (\text{Rated load})} \\
 &= \frac{3 \text{ mV/V} + 3 \text{ mV/V} + 3 \text{ mV/V}}{3 \text{ points}} \times \frac{5 \text{ t}}{3 \text{ points} \times 5 \text{ t}} \\
 &= 1 \text{ mV/V}
 \end{aligned}$$

- ② After making the load cell to the initial load condition (tare weight), execute the calibration according to the paragraph 5-2-1. In this case, input "5000" in the step 6, and input "1.0000" in the step 8 individually.
- ③ If necessity requires, apply zero/span fine adjustment according the paragraph 5-2-4, and 5-2-5.
- (2) When the both conditions of load and the output of load cell are clarified.
(In case that required accuracy is more than 1/1 000 or so.)



Warning

The accuracy obtained through the procedures of this calibration consists from combined accuracy with the instrument and combined strain gage applied transducer, the accuracy of weight used during the calibration, error factors on mechanical and also error factors on calibration works, that is, the total accuracy of these. If high accuracy is required, full considerations should be made on each factor. If neglected, there will be a case that desired accuracy may not be obtained, so care should be taken fully.

When high accuracy is required, actual load calibration by using the weight and so on are required.

For example, we'll show the calibration procedures in the following conditions, that is, 3 points of load cell with 3 mV/V of rated output and 5 t of rated capacity.

Tare weight	1.5 t
Weighing capacity	5 t
Maximum display	5 000

- ① Calculate the output of load cell at the maximum display from the above conditions.
Check that the calculated value at this point is within the range from 0.4 mV/V to 3.1 mV/V.
If the value is out of the range, calibration can't be executed.

(Output of load cell at maximum display)

$$\begin{aligned}
 &= \frac{(\text{Rated output}) + (\text{Rated output}) + (\text{Rated output})}{\text{Number of load cells}} \times \frac{\text{Weighing capacity}}{(\text{No. of load cells}) \times (\text{Rated load})} \\
 &= \frac{3 \text{ mV/V} + 3 \text{ mV/V} + 3 \text{ mV/V}}{3 \text{ points}} \times \frac{5 \text{ t}}{3 \text{ points} \times 5 \text{ t}} \\
 &= 1 \text{ mV/V}
 \end{aligned}$$

- ② After making the load cell to the initial load condition (tare weight), execute the calibration according to the paragraph 5-2-3. In this case, input "5000" in the step 6, and input the load value applied on the load cell in the step 8 individually.
- ③ If necessity requires, apply zero/span fine adjustment according the paragraph 5-2-4, and 5-2-5.

- (3) When the load condition is clarified but the output condition of load cell is not clarified.

In the case of using the existing load detecting section, and adopting the new digital indicator only, it is necessary to execute calibration after checking the output of load cell when its output is not clarified.

For example, followings are calibration procedures when weighing capacity is 5 t and the others are not clarified.

- ① Set the instrument in the monitor mode according to the paragraph 7-19. In this condition, the output level of load cell connecting with the instrument can be monitored up to approx. 3.100 0 with the unit of mV/V.
- ② After making the load cell section to the initial load condition (tare weight), record the display value on load display. This value is the output of load cell at the time of initial load condition.
- ③ Record the display value on load display after applying 5 t load on the load cell section. This value is the output of load cell with weighing capacity applied.
- ④ 4. From the load cell output at the time of initial load application recorded at , and load cell output recorded at at the time of application of weighing capacity, output of load cell at the time of maximum display can be calculated according to the below formula.
Check that the calculated value is within the range from 0.4 mV/V to 3.1 mV/V. The calibration can't be executed if the value is out of the range.
(Output of load cell at the time of maximum display)
= (Output of load cell at weighing capacity) - (Output of load cell at initial load application)
- ⑤ Quit the monitor mode of the instrument.
- ⑥ After making the load cell to the initial load condition (Tare weight), execute calibration according to the paragraph 5-2-1. In this case, the accuracy is less than 1/1 000 or so. At this moment, input each value, "5000" in the step 5 and another input is the value of "Output of load cell at the maximum display" calculated from the in the step 8. If the accuracy more than of 1/1 000 or so is required, execute calibration according to the paragraph 5-2-3. And at the same time, input "5000" in the step 6 and also input "Load value going to apply on load cell" in the step 8 individually.
- ⑦ As necessity requires, make fine adjustment on Zero and Span according to the paragraph 5-2-4 and 5-2-5.

(4) 5-3-1 When replacing the existing CSD-701B with a new one.



Warning

The accuracy in this procedure is less than 1/1 000 or so.

If higher accuracy is required, make calibration by using the actual load according to the paragraph 5-3-1(2).

Moreover, the accuracy described here is a combined accuracy with the instrument and strain gage applied transducer connected.

When another error factors may exist, such as constructional error factors or so, it will become out of warranty for accuracy, so care should be taken fully.

When the load at the section of load cell can't make it with initial load application due to failure on the existing CSD-701B, execute calibration by referring to the procedures as below. However, in case that the initial load condition can be obtained, make calibration according to the procedures of (1) and (2).

- ① According to the paragraph 8-1, read out and write down the function F-90 "Increment value", the F-91 "Maximum display value", the F-93 "Zero calibration value", and the F-94 "Span calibration value" in the existing CSD-701B.
- ② According to the paragraph 4, replace the exiting CSD-701B with a normal instrument and make connections.
- ③ After turning ON the normal instrument, make calibration according to the paragraph 5-2-2. In case of this, input the "Increment value" recorded at in the step 3, the "Maximum display value" in the step 5 and the "Zero calibration value" in the step 7 and in the same way, input "Span calibration value" in the step 9.

5-3-2. When the calibration is executed again.

When purchasing a new instrument and the combined inspection has executed at Minebea, however, the tare weight has changed, or fine adjustment on zero and span are required, make calibration with whichever the following methods.

(1) Calculation on tare weight only

(When combined inspection has completed at Minebea and calibration on only tare weight is required.)

When the initial load (tare weight) has changed after completing the calibration, or when the combined inspection at Minebea has been made and the calibration only for the initial load(tare weight) is required after the installation, proceed the calibration in the following steps.

① After setting the initial load (tare weight) on load cell section, execute calibration according to the paragraph 5-2-6.

(2) In case of executing fine adjustment on zero and span

Make adjustment according to the paragraph 5-2-4(Fine adjustment on zero), and 5-2-5 (Fine adjustment on span).



Warning

The accuracy obtained through the calibration procedures consists from combined accuracy with the instrument and strain gage applied transducer, the accuracy of weight used during the calibration, error factors on mechanical and also error factors on calibration works, that is , total accuracy of these.

If high accuracy is required, full considerations should be made on each factor. If neglected, there will be a case that the desired accuracy shall not be obtained.

5-4. Setting the prohibition against calibration

After completing all of the calibration procedures, setting can be made to prohibit any more calibration again by setting the function(Related function F-97).

For details, refer to the paragraph 7-17.

6. Operation procedure

We'll show the operating procedures with keys located on the front panel.

 **Warning** Each key operation should be made after interrupting the measurement. If it is made during measurement, it may cause an unexpected malfunction.

 Key operation in Measurement mode can be effective by pressing it for about one second or so.

6-1. key

6-1-1. Operations in Measurement mode

(1) When it is operated alone.

The Function mode can be entered, and the “FUNC” is shown on the load display section. In this condition, setting on the Function or shifting to another modes can be available.

(2) When it is operated while the press of  key.

If you will operate while the press of  key, the CHECK value set in function F-11 is turned on, and “CHECK” in the condition display section lights. At the same time, the load value which corresponds to the value set in the load indicated value with F-11 is added.

After operating while the press of  key, the CHECK value is turned off, and returns to the former status.

6-2. key

6-2-1. When operating in the measurement mode

The set value of comparator S1 is displayed at the same time as S1 LED blinking, 10^0 digits blink, and setting the set value of comparator S1 becomes possible.

Moreover, the display automatically returns to the measurement mode when leaving without operating key of anything under such a condition for about 20 seconds.

The changed set value is registered internally when do the press of  key, and the operation comes off the status where the S1 set value can be set.

6-2-2. Operation is made in another mode

(1) Carrying up the set value.

By pressing the  key with the condition of displaying various kinds of set values, the flashing digits for set value will carry up from 10^0 , 10^1 , 10^2 , 10^3 to 10^4 in order.

(However, the range of carry differs depending on the number of digits of set values and yes/no of polarity sign.)

(2) Change of function and so on.

Executes change of various kinds of functions in Function mode, and also change of function during Check mode.

(3) Decrement at the time of fine adjustment.

When the  key is pressed at the time of making fine adjustment on ZERO, SPAN and analog output, the targeted value will decrease.



In the operation method of the paragraph 6-2-2(3), when the key is pressed for more than about 1 second, each operation will be executed continuously at a constant interval without ON/OFF operation of the key.

6-3. key

6-3-1. When operated in the Measurement mode.

(1) When it is operated alone.

At the same time the LED for S2 is flashing on and off, the Comparator S2 set value will display and the 10^0 digit will flash on and off that makes to possible to set the set value for Comparator S2. And if you keep the instrument untouched for approx. 20 seconds, the

Measurement mode can be re-entered automatically. Pressing the  key makes to register the set values internally, then the condition of “Possible to set value for S2” can be over.

(2) When it is operated while the press of key.

If you operate while the press of  key, the zero set function works by this operation when the display value in the load display section is within 10 % of the maximum indicated value (Refer to the paragraph 5) and makes the display “0” compulsorily.

Please refer to details by the paragraph 7-12.

6-3-2. When operated in another modes

(1) Increment of set value

By pressing the  key with the condition of displaying various kinds of set values, the set value will increase per one count from 0, 1, 2, 3, 4, 5, 6, 7, 8, 9 and 0 again in order.

(2) Increment at the time of fine adjustment

When the  key is pressed at the time of making fine adjustment on ZERO, SPAN and analog output, the targeted value will increase.



In the operation method of the paragraph 6-3-2(2), when the key is pressed for more than about 1 second, each operation will be executed continuously at a constant interval without ON/OFF operation of the key.

6-4. key

6-4-1. When operated in the Measurement mode.

(1) When the peak function is selected (Lighting off the Status display “ ”).

Changeover the display of peak value/track value.

(2) When the A/Z function is selected (Lighting up the Status display “ ”).

At the same time the Tare weight cancellation (A/Z) works and the load display value become the net weight display value, the “A/Z” on the status display will light up and load display becomes “0”.

6-4-2. When operated in another modes

(1) Calibration

The set value is initialized in each procedure of the calibration method.

(2) Function mode

In the function mode, the function number and the set value of the function are compulsorily made “0”.

(3) Comparator setting

The set value is compulsorily made “0” with the set value of the comparator can set.

6-5.  key

6-5-1. When operated in the Measurement mode

(1) When the peak function is selected (Lighting off the Status display “ ”).

Set the display ”0”, and reset the peak value.

(2) When the A/Z function is selected (Lighting up the Status display “ ”).

At the same time the Tare weight cancellation clear(A/Z OFF) works and the load display value become the gross weight display value, the “A/Z OFF” on the status display will light up.

6-5-2. When operated in another modes.

When the  key is pressed while entered in various kinds of modes, you can shift to the Measurement mode.

6-6.  key

Pressing the  key makes to register the set values internally, then the condition of “Possible to set” will be over.

7. Function and operation

7-1. External control input signal and contact output signal

The instrument is available to the external control through various kinds of input signals.

7-1-1. Input signal for external control



Activates by shortening with COM.1 (Terminal No. 8).

Terminal No.	Name	Operation
9	ZERO	When the indicated value on load display is within 10 % against the maximum display value, zero set function will activate by the operation and make the display "0" compulsively. (Same key operation in the paragraph 6-3-1.) As for the operational details, refer to the paragraph 7-12.
10	HOLD	While inputting the signal, the target selected with Function F-10 among display, contact output, analog output and options will be frozen. As for the operational details, refer to the paragraph 7-9.
11	PEAK /TRACK /A/Z	Changeover of track value and peak holding value. Moreover, when the A/Z function is selected with F-70, it executes the tare weight cancellation.(A/Z ON) Open : Track value Short : Peak holding value
12	RESET /A/Z OFF	During the peak hold operation, the reset condition is made by short circuit. And tare weight cancellation clear(A/Z OFF) when A/Z function is selected with F-70.
8	COM.1	The common for the input signal (Terminal No. 9 to 12)



Operation of input signal will be executed after shortening for more than 100 ms approximately.

Only A/Z and the A/Z OFF function are pulse input, and it is effective once in the pulse width of 100 ms or more.

When the ZERO signal(or the  +  key on the front panel) is input while inputting the HOLD signal, the operation of ZERO is executed simultaneously with the release of the HOLD signal.

When the HOLD signal is input in the status of power supply OFF, and the power supply is turned on, it is displayed in load display panel as " HOLD". The load is displayed simultaneously with the release of the HOLD signal.

The COM. 1 (terminal No. 8) and the COM.2 (terminal No. 13) are isolated.

7-1-2. Contact output signal

Terminal No.	Name	Operation
14	S1	The contact output for comparator S1. 1a contact.
15	S2	The contact output for comparator S2. 1a contact.
13	COM.2	The common for the contact output(terminal No.14 to No.15).



COM.1 (terminal No. 8) and COM.2 (terminal No.13) are insulated.

The comparator of the instrument executes the comparison operation synchronizing with the display.

The delay time starting from preparing the output conditions to the contact output ON, will be 5 ms approximately.

7-1-3. Equivalent circuit

(1) External control input section

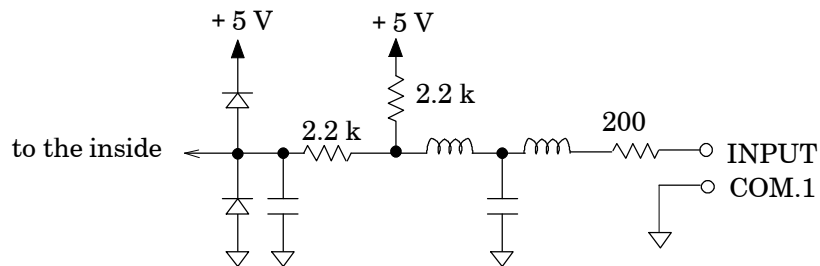

(2) Contact output section

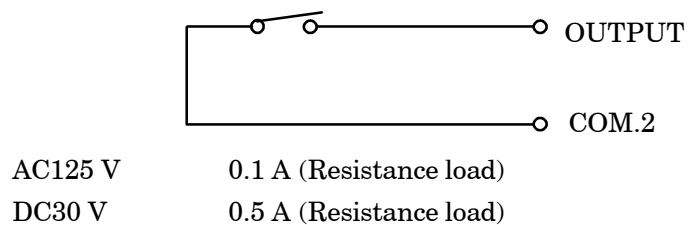

7-2. Comparator

The instrument provides with the comparator by two set values of S1 and S2.



The comparator of the instrument executes the comparison operation synchronizing with the display.

7-2-1. ON/OFF of comparator S1 and S2

Operational selection of ON/OFF can be made for each comparator S1 and S2. These selections are done by the function (related function F-30). Default has selected both S1 and S2 turning on.

7-2-2. Change of set value





Warning

When the set value for the comparator is set wrong, or set in the wrong procedures, it may not obtain the correct results from the comparator, and it may cause malfunctions in peripheral equipments and also cause a damage as well.

Procedures

Change of S1 set value

In the Measurement mode, pressing the  key makes the 10⁰ digit and the judgement display S1 on the front panel load display will flash on and off, then change of S1 setting can be available.

Every time the  key is pressed, the flashing digit will change from 10⁰ digit 10¹ digit 10² digit 10³ digit 10⁴ digit Polarity(POL) 10⁰ digit.



Change the set value by the  key after flashing the digit which is desired to change.





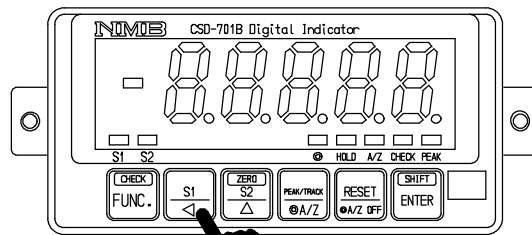





If you keep the instrument untouched for approx. 20 seconds in the condition of change of setting is available, the Measurement mode can be re-entered automatically.

After fixing up the change, press the  key. Make the set value effective, then the Measurement mode can be entered again.

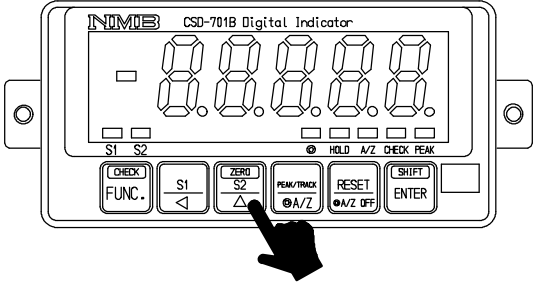

-  : Set value carry key
-  : Set value inclement key
-  : Set value initialization key (Make the set value to "0".)

1

Procedures		
2	<p>Change of S2 set value</p> <p>In the Measurement mode, pressing the  key makes the 10⁰ digit and the S2 judgement display on the front panel load display flashing on and off, then change of S2 setting can be available.</p> <p>Every time the  key is pressed, the flashing digit will change from 10⁰ digit 10¹ digit 10² digit 10³ digit 10⁴ digit Polarity(POL) 10⁰ digit. Change the set value by the  key after flashing the digit which is desired to change.</p> <div style="border: 1px solid black; padding: 5px; margin: 10px 0;">  If you keep the instrument untouched for approx. 20 seconds in the condition of change of setting is available, the Measurement mode can be re-entered automatically. </div> <p>After fixing up the change, press the  key. Make the set value effective, then the Measurement mode can be entered again.</p>	<div style="text-align: center;">  </div> <ul style="list-style-type: none">  : Set value carry key  : Set value increment key  : Set value initialization key (Make the set value to "0".)

7-2-3. Operation on comparator S1 and S2

The comparator in the instrument, S1 and S2 can select the operation whichever “contact ON at more than the set value”, or “contact ON at less than the set value”. This selection can be made in the Function mode. (Related function F-32)

As for default, the “contact ON at more than the set value” is selected for both of S1 and S2.

 **Warning** Depending on the operational selection for comparator, ON/OFF condition for each contact output may differ. If wrong operation is selected, ON/OFF condition for contact output becomes inadequate and it may cause an unexpected accident due to malfunctions on peripheral instruments, so care should be taken fully.

 When the load display is “OL” or “- OL”, the “display value” for the comparison of comparator is assumed as “+ (infinity)” and “- (infinity)” individually.

Operation on judgement display section and contact output will be shown as an example of S1 below. The operation becomes similar as for S2.

(1) When the operation of “contact ON at more than the set value” is selected.

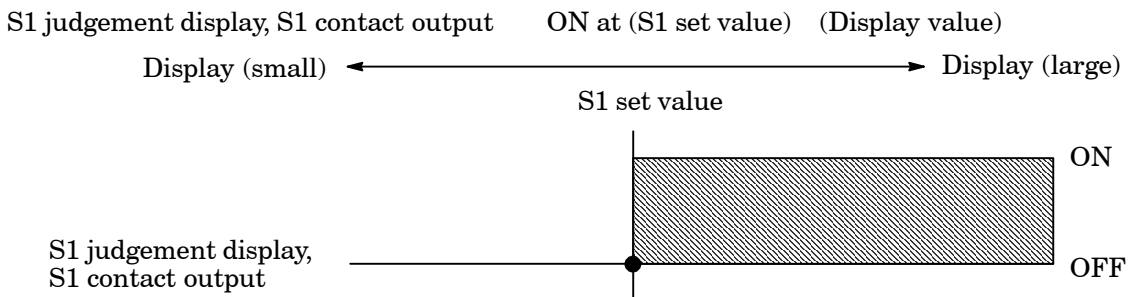

(2) When the operation of “contact ON at less than the set value” is selected.

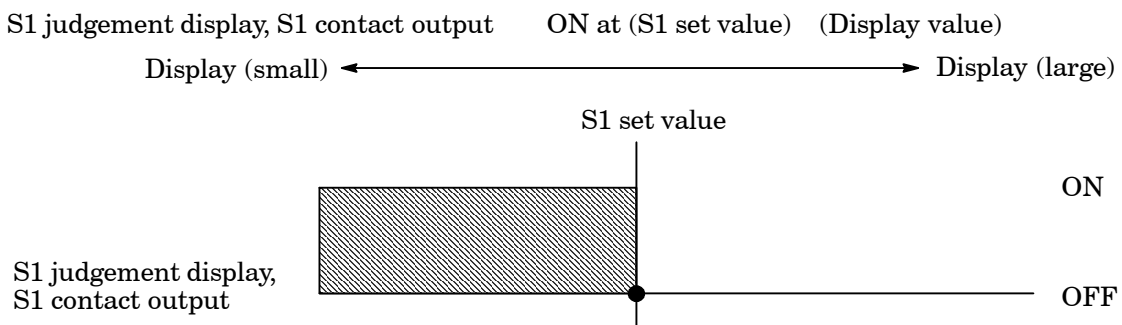

7-2-4. Comparative target for comparator S1 and S2

The comparator in the instrument, S1, S2 individually can select the comparative target from the two, that is, “PEAK/Net weight”, “TRACK/Gross weight”. This selection can be made in the Function mode. (Related function FUNC-31) As for default, the “TRACK/Gross weight” is selected for both of S1 and S2.



Warning

The ON/OFF condition of each contact output is different according to the comparison target selection of the comparator. If wrong operation is selected, ON/OFF condition for contact output becomes inadequate and it may cause an unexpected accident due to malfunctions on peripheral instruments, so care should be taken fully.

Operation on judgement display section each comparative target and the operation of contact output will be shown as follows when the operation of “contact ON at more than the set value” is selected by the S1, for an example. The same is the operation of S2.

- (1) When the operation of “PEAK/Net weight” is selected.

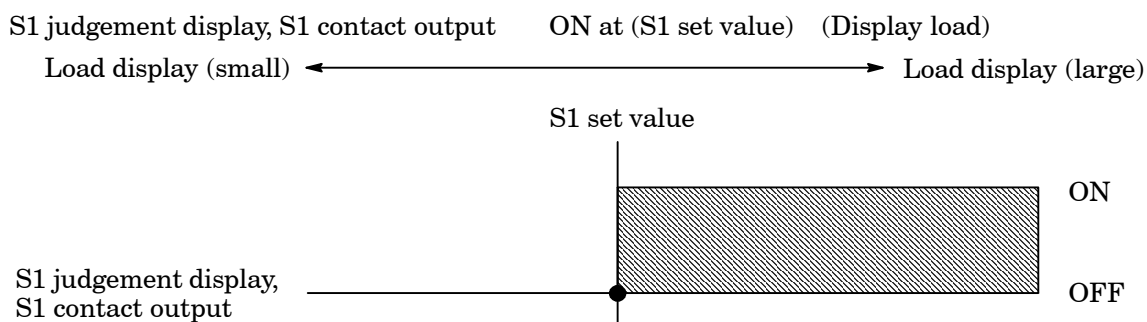

- (2) When the “TRACK/Gross weight” is selected.

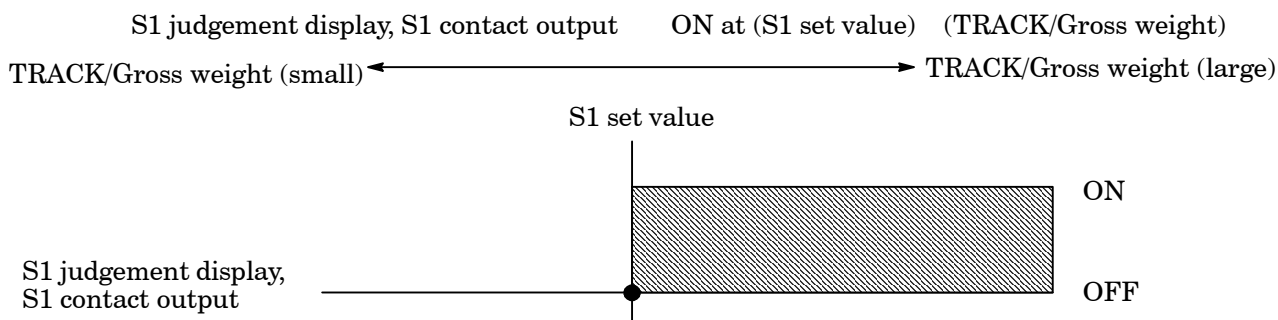

7-2-5. Hysteresis on comparator

Comparator S1 and S2 of the instrument can set the hysteresis because of the chattering prevention of the output relay.

Hysteresis can be used by combining setting by the width of data and combining setting by the time width. Moreover, effective directions of hysteresis can be selected from either "Off delay" or "On delay".

These selections are done in the function mode (related function F-34, F-35, and F-36).

Default has set hysteresis "OFF".

 **Warning** Depending on the setting of comparator hysteresis, ON/OFF condition for each contact output may differ. If wrong mode is selected, ON/OFF condition for contact output becomes inadequate and it may cause an unexpected accident due to malfunctions on peripheral instruments, so care should be taken fully.

The operation of judgement display panel and the contact output when the hysteresis of the comparator is set is shown as an example of S1 below.

The operation becomes similar as for S2.

- (1) When the operation of "contact ON at more than the set value" is selected at S1 and also effective direction for hysteresis is set as "On delay".

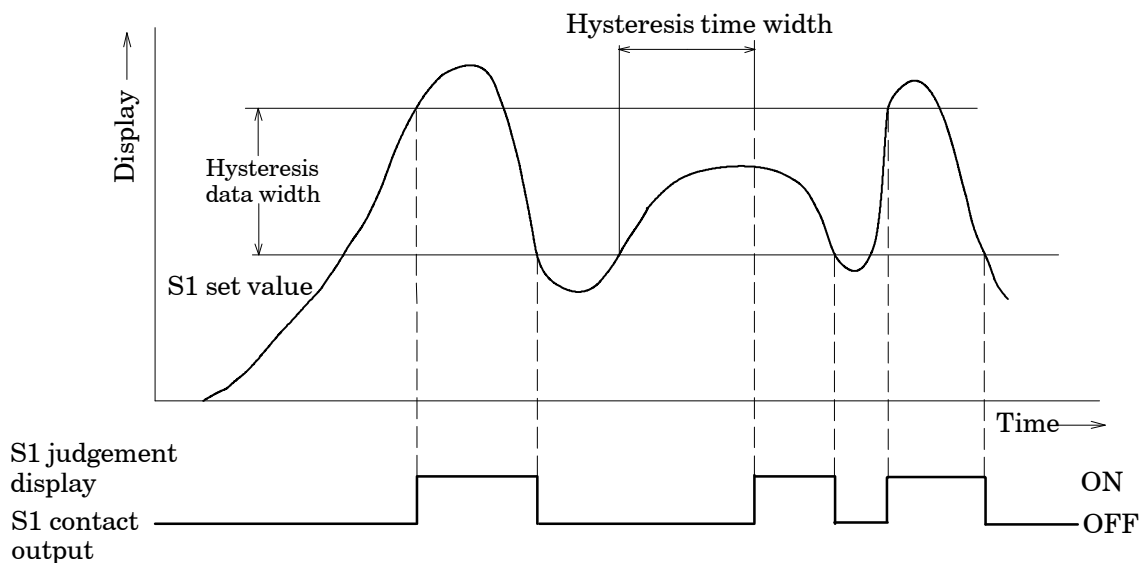

- (2) When the operation of “contact ON at more than the set value” is selected at S1 and also effective direction for hysteresis is set as “Off delay”.

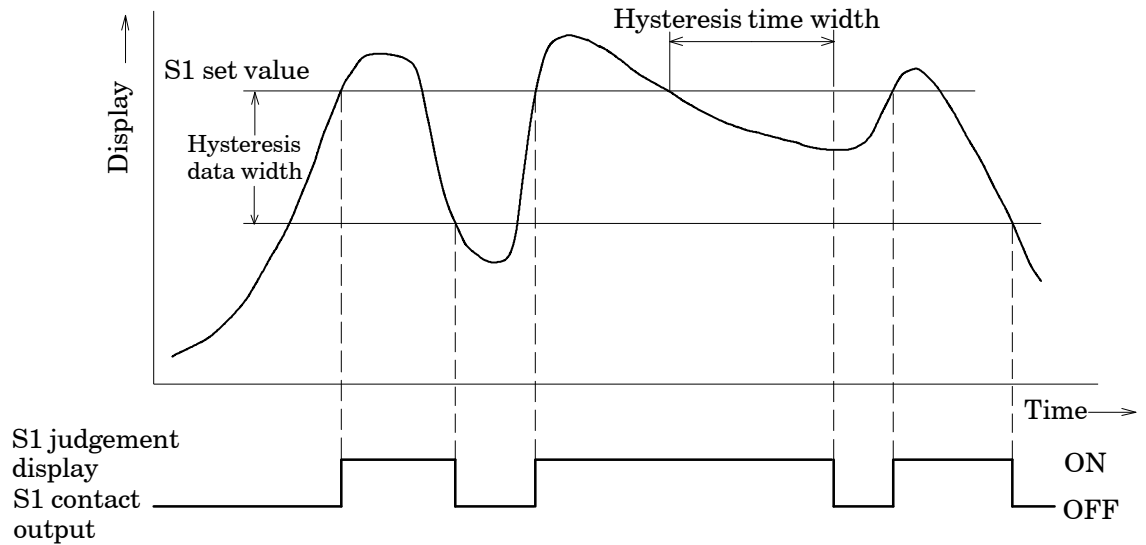

- (3) When the operation of “contact ON at less than the set value” is selected at S1 and also effective direction for hysteresis is set as “On delay”.

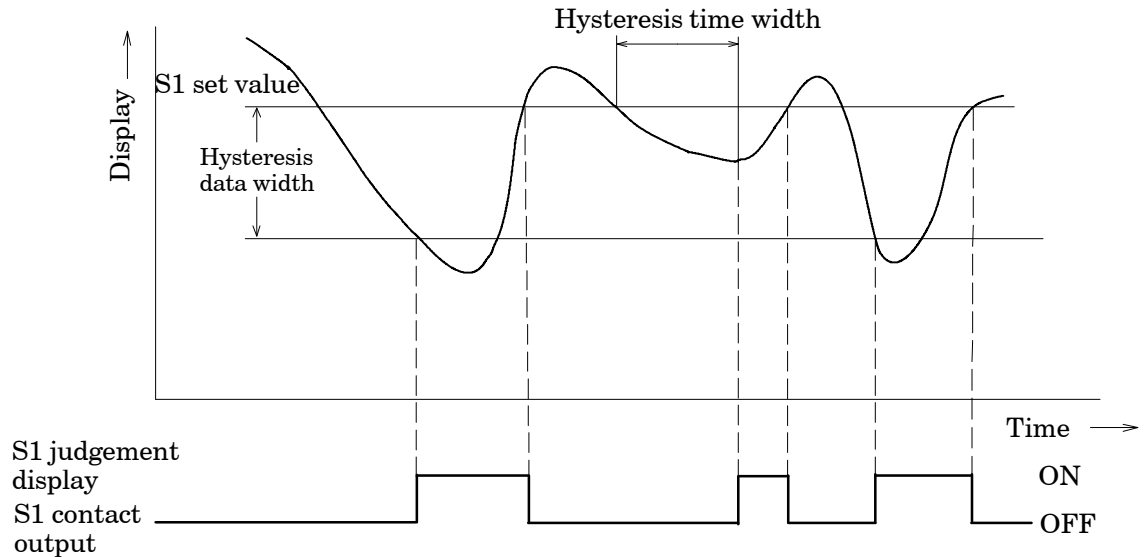

- (4) When the operation of “contact ON at less than the set value” is selected at S1 and also effective direction for hysteresis is set as “Off delay”.

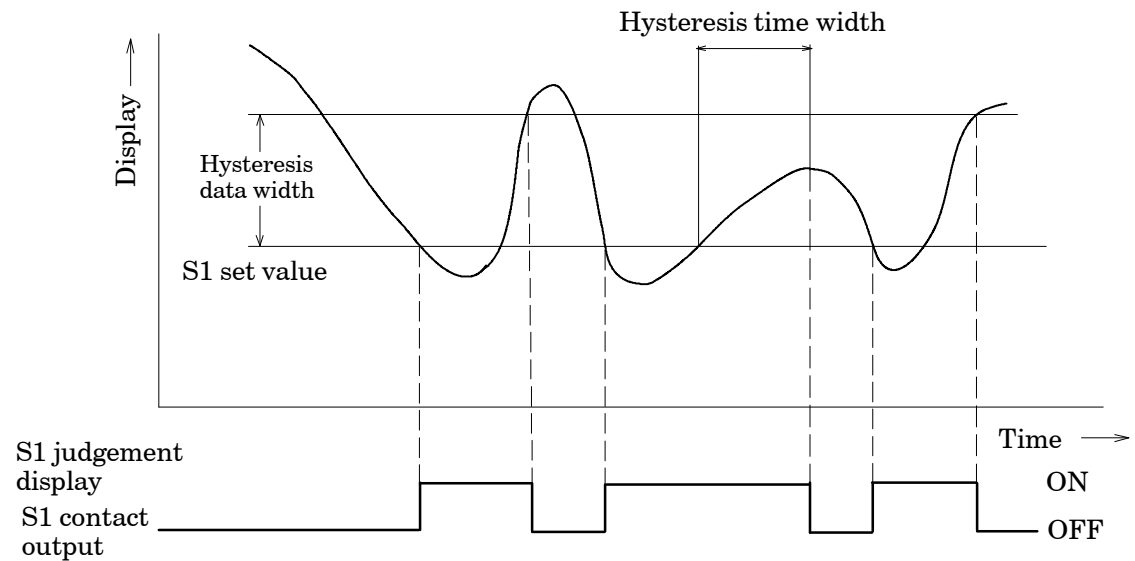

7-3. How to use the filter

The instrument has the digital filter to which the data converted into digital is stabilized by the calculation processing.

 **Warning** When setting filter is not suitable, correct measurement can't be made and it may cause an unexpected accident, so care should be taken fully.

7-3-1. Digital filter

The digital filter for the instrument can be set from "00000" to "00007".

The averaged-out times of digital filter can be decided from the set value (Related function F-04)

As for default, "00004" is selected.

The relations between the setting and the averaged-out times are as follows :

$$(\text{Averaged-out times}) = 2^n \quad n : \text{Set value}$$

For example, when "00004" is selected, averaged out times is as follows :

$$\begin{aligned} (\text{Averaged-out times}) &= 2^4 \\ &= 16(\text{Times}) \end{aligned}$$

The tendency to the characteristic by the leveling frequency is shown in the table below. :

Averaged out times	low		high
Resist to noise	rapid	\longleftrightarrow	stable
Response speed	quick	\longleftrightarrow	slow

7-4. Zero tracking

The instrument prepares the zero tracking in order to compensate for slow drift of zero.

 Effective only when the A/Z mode is selected. (Related function F-70)

7-4-1. What is zero tracking?

- Zero tracking is a function to cancel the slow drift of zero within the constant conditions, and also to follow the zero point of the instrument in order to stabilize zero point.
- When the data variation within the set time with function F-09 is within the set value set with the function F-08 against the zero point, then the input will be cancelled as the zero point. However, when the zero point compensation for the total " ± 10 % of the maximum display value" at the zero tracking and zero set are completed until that time, the further directional zero tracking will not executed.

7-4-2. Setting related with zero tracking.

- Set the data width that performs zero tracking with the function F-08. The zero tracking width per setting value “n” will be obtained by the calculation of display according to the below formula.

$$(\text{Zero tracking data width}) = (\text{Set value of F-08}) \times 0.5 \times (\text{Increment value for display})$$

For example, when the setting of function F-08 is “00010” and the increment value for display is “D=5”, then (Zero tracking data width) will be as follows:

$$\begin{aligned} (\text{Zero tracking data width}) &= 10 \times 0.5 \times 5 \\ &= 25D \end{aligned}$$

- Set the time width performs zero tracking with the function F-08.



The zero tracking will not operate whichever the function F-09 or the function F-70 is set as “0”, or the function F-70 is “0”.

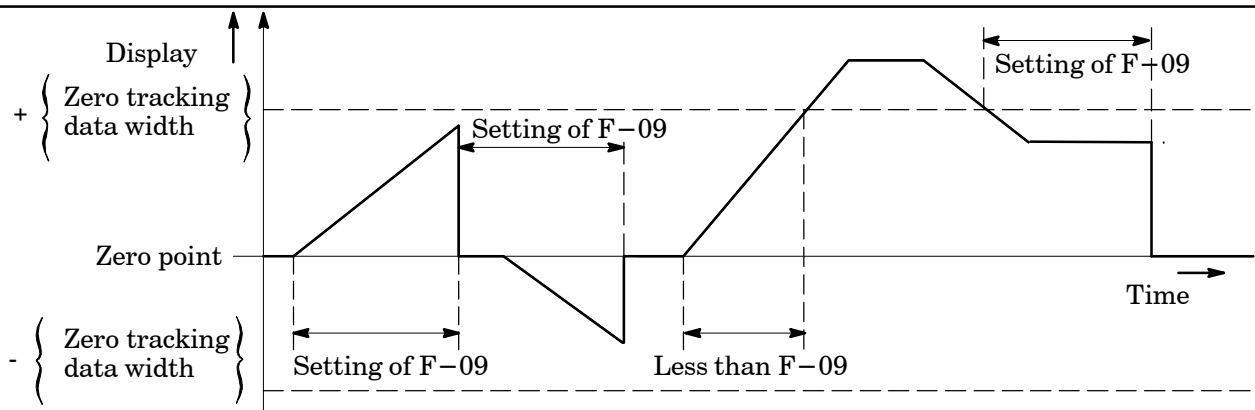

When the load shows slow vibration in the vicinity of zero, never use the zero tracking.

When the variation of load display becomes moderate due to the strength/weakness of the digital filter and stabilized filter, there may have the case that the zero tracking becomes effective even when the actual load variation is rapid, so care should be taken fully.

7-4-3. Cancellation for compensation by zero tracking

Cancellation for compensated data by zero tracking can be executed with the function F-98.



When changing the target for zero tracking is required, be sure to cancel the compensated portion by zero tracking once using the function F-98.

The zero tracking of the instrument will become effective at the time of the load display will be the gross weight. In due course, at the time of A/Z ON, the zero tracking will not work.

7-5. Stabilized filter

The instrument prepares the Stabilized filter that can filter through digital filter strongly when variable width for load is within the constant value and also the same condition is frozen for more than a constant period.

7-5-1. What is the Stabilized filter?

When the variable width of load is within the set value by the function F-17 and also the same condition is frozen for more than the set value with the F-16, the digital filter for stabilized filter will become effective set with the function F-15. That is, the digital filter will be applied only when the load is stable for more than a constant value, and then stabilizes the load display.

7-5-2. Setting related with the Stabilized filter.

- Set the data to apply the Stabilized filter with the function F-17. The stabilized filter width per set value “n” can be obtained through the display conversion by using the following formula.

$$[\text{Stabilized filter data width}] = [\text{Set value of F-17}] \times [\text{Display increment value}]$$

For example, when the setting of function F-17 is “00010” and the display increment is “D=5”, then

$$\begin{aligned} [\text{Stabilized filter data width}] &= 10 \times 5 \\ &= 50 \end{aligned}$$

- Data width supervisory time for the Stabilized filter can be set with the function F-16.
- The digital filter for Stabilized filter can be set with the function F-15.
- The averaged-out times for the digital filter for Stabilized filter per set value “m” can be obtained by the following formula.

$$[\text{Stabilized filter averaged-out times}] = 2^m$$

For example, when the setting of function F-15 is “00002”,

$$\begin{aligned} [\text{Stabilized filter times}] &= 2^2 \\ &= 4(\text{Times}) \end{aligned}$$

- Moreover, when the digital filter has set with the function F-04, the averaged-out times will be “Stabilized filter averaged-out times” and “Averaged-out times” with the function F-04. (Refer to the paragraph 7-3.)

That is,

$$\begin{aligned} [\text{Averaged-out times}] \\ &= [\text{Averaged-out times with the F-04}] \times [\text{Averaged-out times of stabilized filter}] \end{aligned}$$

For example, setting for the function F-04 is “00004” and the function F-15 is “00002” as well, it will be as follows:

$$\begin{aligned} [\text{Averaged-out times}] &= 2^4 \times 2^2 \\ &= 16 \times 4 \\ &= 64(\text{times}) \end{aligned}$$

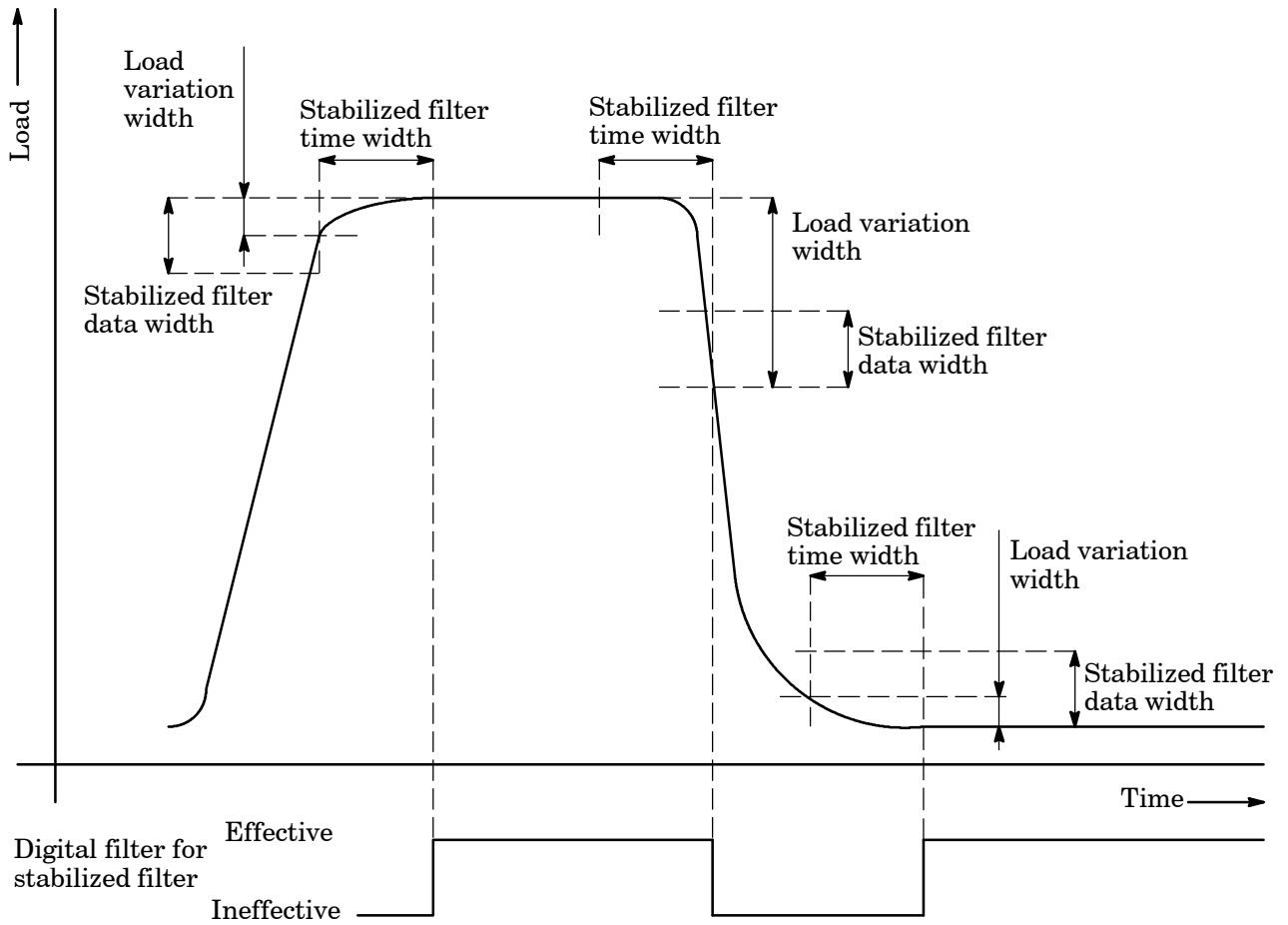

7-6. Change of Peak function and A/Z function

We can use the instrument by selecting one whichever the “peak function” or the “A/Z function”. This selection can be performed in the Function mode. (Related function F-70.)

7-7. How to use the peak hold.

The instrument provides the peak holding function.

The maximum value of the load is held.

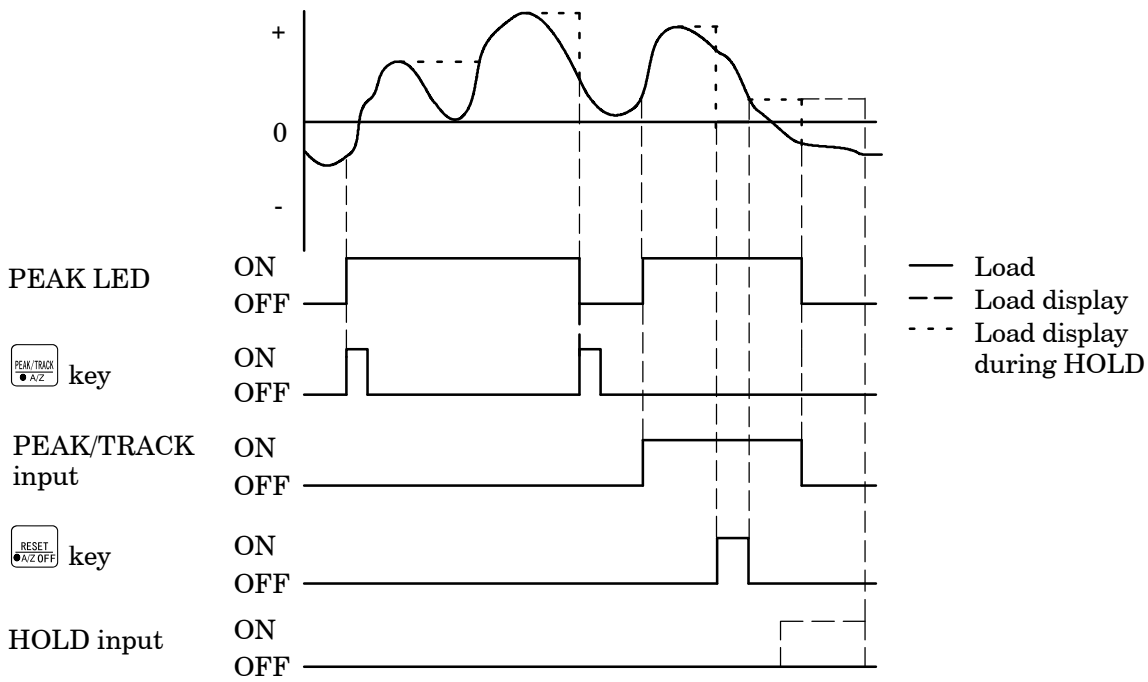

At the time of short of PEAK/TRACK input, the peak hold condition will not change even if the  key is pressed ON.

7-8. Various functions concerning display

7-8-1. Selection of target of display

The instrument can select the display frequency from 4 times/s and 20 times/s. This selection is done in the function mode (related function F-03). Default has selected 4 times/s.



The comparator of the instrument executes comparative operation synchronous with the display. Besides, the conversion of analog output is synchronous with the display.

In due course, when changing of conversion times of comparator, and also conversion times of analog output is/are required, execute the change of display times with the function F-03.

7-8-2. Selection of position of decimal point display

The instrument can display the decimal point at the “Load display section” of the instrument. The selection of display can be made in the Function mode. (Related function F-01) Default has selected “No decimal point display”.

7-8-3. Load display range

The load display range for the instrument is fixed from the - 10 % to 110 % of the maximum display value at the time of setting during calibration. When less than the range, “ - OL” displays and over the range “OL” displays. For example, when the maximum display value is “1 000”, the load display range will be from - 100 to 1 100.

Besides, when under - 100, the “ - OL” displays, and over 1 100, the “OL” will display.

7-9. Selection the target for HOLD

The instrument can select the target for HOLD function among “load display”, “comparator contact output of S1 and S2, LED display”, “Analog output” and “Options”.

This selection can be made in the Function mode (Related function F-10).

As for the default, “All is selected.” Layout of setting for the F-10 are as follows :

10⁰ digit : Load display



10¹ digit : Contact output of comparator S1 and S2, LED display

10² digit : Analog output

10³ digit : Optional output

With the “0” setting, out of the target, and with “1” setting, target of HOLD.



When HOLD target “Load display” is selected,  key,  key and



key becomes invalid.

7-10. Change of bridge power supply voltage

The instrument can select the bridge power supply from “5 V” and “2.5 V”. This selection can be made in the Function mode(Related function F-12). Default has selected “5 V”.



When the bridge power supply voltage is changed, please execute the calibration again.

7-11. Tare weight cancellation (A/Z)

The instrument prepares Tare weight cancellation (A/Z) function.

Pressing the  key makes Tare weight cancellation (A/Z) function operated and when the load display becomes net weight display, at the same time, the “A/Z” lights up on the status display and load display value becomes “0”.

Moreover, when the  key is pressed, Tare weight cancellation clear(A/Z OFF) function will activate and at the same time when the load display value becomes gross weight, the “A/Z” on the status display will put off.





When tare weight cancellation (A/Z) function is required, select “00001 : A/Z function effective” by function F-70.

Upon this selection, “ ” on the status display will be light on, and A/Z function will be active.

7-12. Zero set

The instrument prepares zero set function.

When the display value on load display is within 10 % against the maximum display value (Refer to the chapter 5.), by press of the  key together with the press of  key, the zero set function works and the display is made “0” compulsorily.

However, zero set will not be accepted when zero compensation for total $\pm 10\%$ is executed with zero set and zero tracking until that time. (ERR-0 display)

Also, the same operation can be made with the operation of “ZERO” at the input signal of external control. Cancellation for data applied zero compensation by zero set can be executed with Function F-98.





When tare weight cancellation (A/Z) is executed (during A/Z display lights up), zero set will not be accepted. It will display “ER-5”.



When zero set is desired to execute, execute after making the Tare weight cancellation clear (A/Z OFF).



7-13. Lock of key function



The instrument prepares the lock of key function.

With the Function F-06, execute the lock OFF of key function by setting each digit=0, and executes lock ON of key function by setting each digit=1. As for default, "all is lock OFF of key function". Besides, the correspondence between the target of key function and setting digits are as follows:

10^0 digit : ON/OFF of CHECK value(Press the  key in the condition of pressing the  key.)



10^1 digit : ON/OFF of Peak Hold function, A/Z ON() , Reset of the peak value, A/Z OFF()

10^2 digit : Reading out the change mode of S1 setting() , Reading out the change mode of S2 setting()



10^3 digit : Execute the zero setting(Press the  key in the condition of pressing the  key.)



10^4 digit : Reading out the function mode()

Moreover, when the reading out the function mode is locked, the function mode can be

proceeded after pressing the  key for over 2 seconds in the condition of pressing the  key for over 1 second.

7-14. CHECK value

By press of  key together with the press of  key in the Measurement mode, CHECK value equivalent to the set value with the Function F-11 will be ON. And at the same time when the "CHECK" on status display lights up, the load value equivalent to the set value with Function F-11 will be added to the load display value. As for default, 0.4 mV/V has set.

By press of the  key together with the press of  key again, the CHECK value will be OFF and returns to the former condition as it is.



When the setting of Function F-11 is "00000", load display value will not vary even if the "CHECK" lights up on the status display.
(Because CHECK is 0.0 mV/V.)

7-15. How to use the analog output



Warning

When the power supply is turned on with shorting the external HOLD signal, the analog output will be made as follows:
When the target of HOLD by F-10 is the analog output, the analog output will become the minimum value.

Be careful on the following point when CHECK function is used.
The "OL" error display(Analog output at OVR.) will be displayed by making CHECK effective.



The analog outputs for the instrument are 2 type of "Voltage output" (Standard) and "Current output"(Optional).

The analog output of the instrument executes re-writing the outputs synchronous with the display.

The resolution of the analog output of the instrument is approx. 1/10 000 against the voltage output from 0 V to 5 V, and the current output from 4 mA to 20 mA.

The analog output has possibility of the output variation when the power is turned on. To take the stable condition, use the instrument about one hour after the power has been turned on.

7-15-1. Scaling of analog output

The analog output for standard specifications is set between the minimum value and the maximum value with the output of 0 to 2 000.

By changing the F-21 and F-22, optional value can be decided.

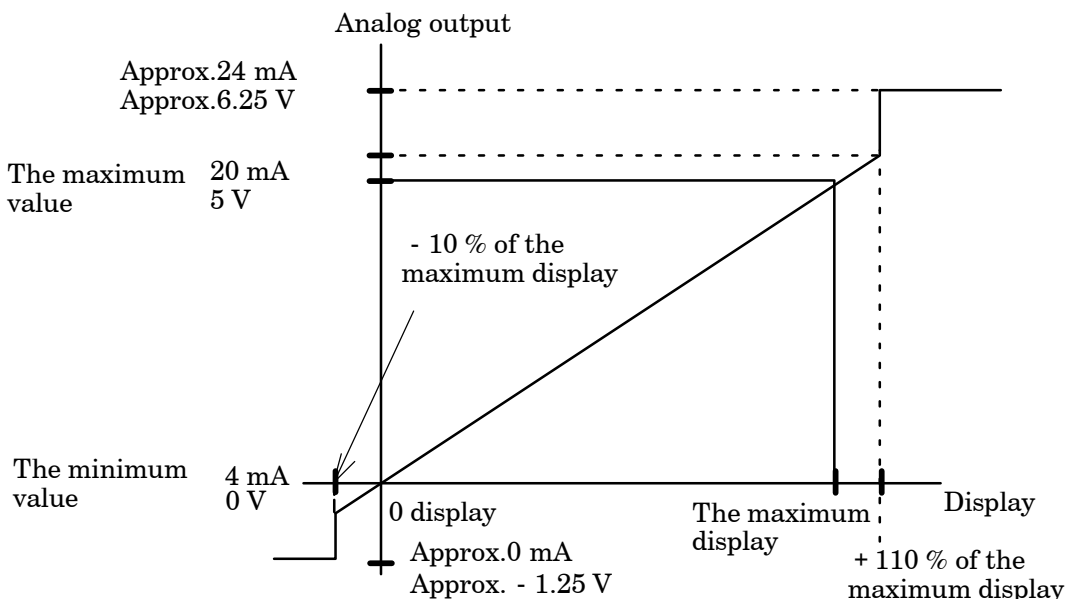

F-21 sets the display when the minimum value is desired to output.

F-20 sets the display when the maximum value is desired to output.

(Example) F-21 : Set as 1 000

F-22 : Set as 5 000

When the display is 5 000, the maximum value outputs.

When the display is 1 000, the minimum value outputs.

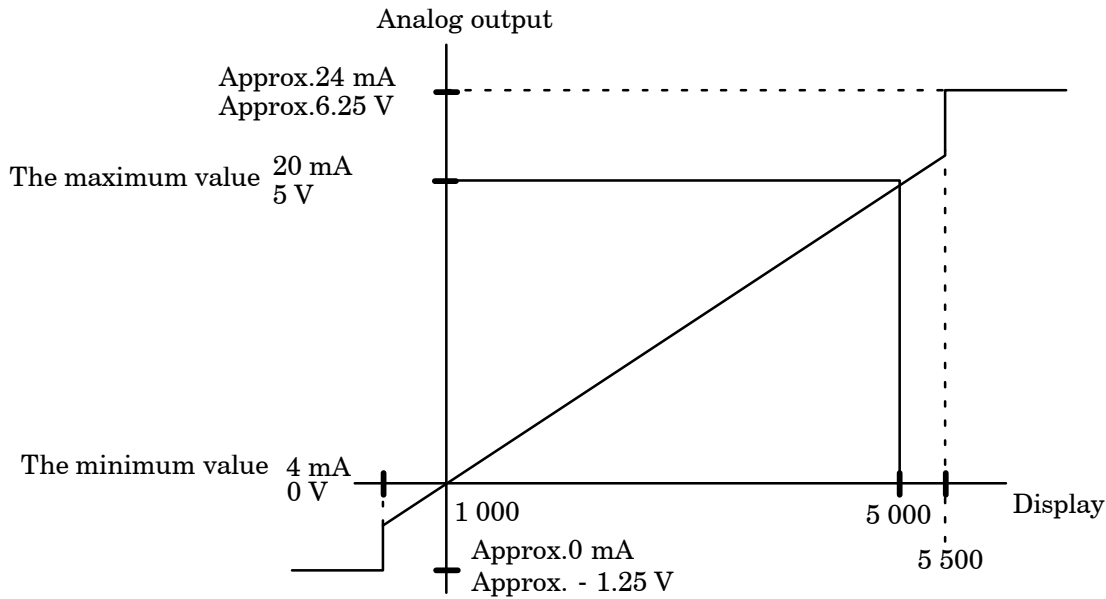

Warning

Setting F-22 must not exceed the maximum indicated value set in chapter 5.



In F-21, please set smaller value than the value set with F-22.
If neglected, the correct output can't be obtained.

7-15-2. Fine adjustment 1 on analog output

Fine adjustment described here, is the one to arrange each “the minimum value” and “the maximum value” without applying the actual load during the procedures. Refer to the paragraph 7-15-3, for the fine adjustment with actual load applied.



During the application on fine adjustment, if you want to suspend, press the  key. The minimum value data and the maximum value data are kept as they were before entering the fine adjustment, and the Measurement mode can be re-entered.

Please execute the fine adjustment after about one hour has passed since the power supply was turned on. The fine adjustment can be executed in the status of the stable or more.

Procedures

1

Press the  key for about one second.
The load display will show "FUNC".

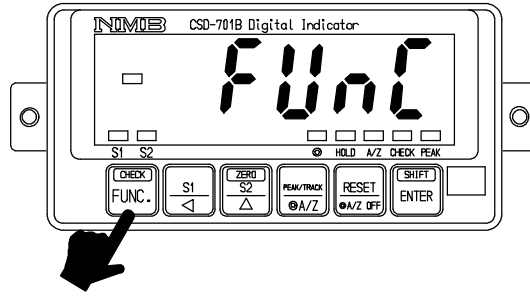

2

Press the  key 9 times.
The load display will change as "FUNC"
"CCAL" "ACAL" "LCAL" "ZERO"
"SPAN" "TARE" "CHEK" "MONT"
"VCAL".

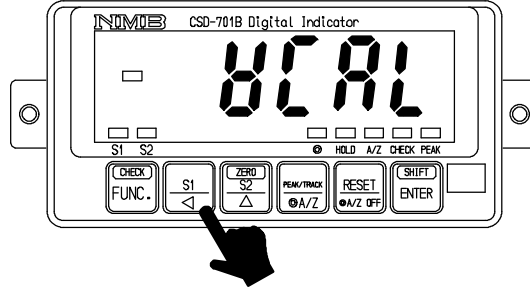

3

Press the  key.
The load display will show "ALOW".

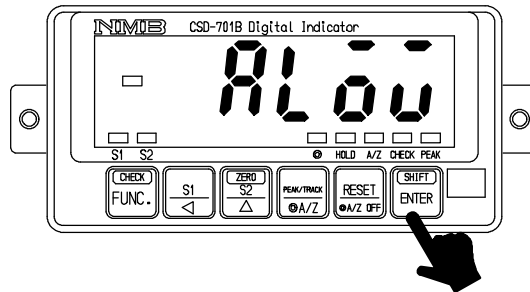



4

Press the  key.
The load display will flash on and off showing
"ALOW".
At the same time, the analog output equivalent
to the minimum value of analog output will be
obtained.
Adjust so the output will become the minimum
value with the right keys.



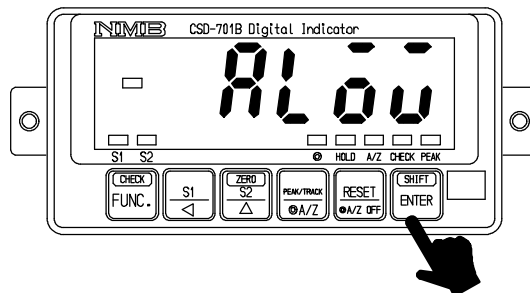



	Voltage output (Standard)	Current output (Optional)
Minimum value	0 V	4 mA

 It can be increased continuously by the
continuity press of the key.

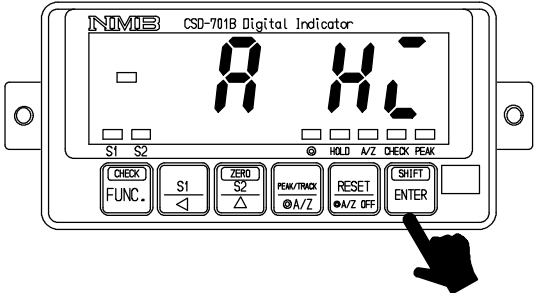

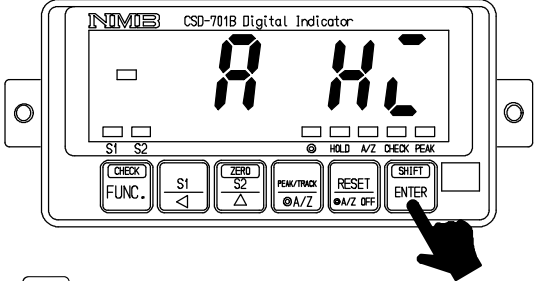
 key : Decrease the analog output

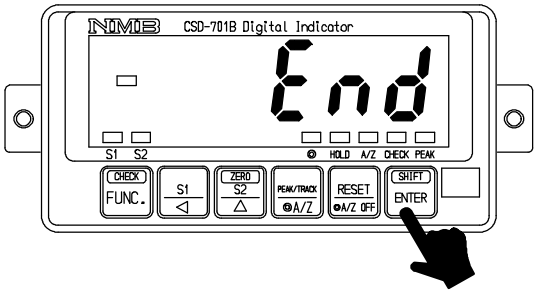
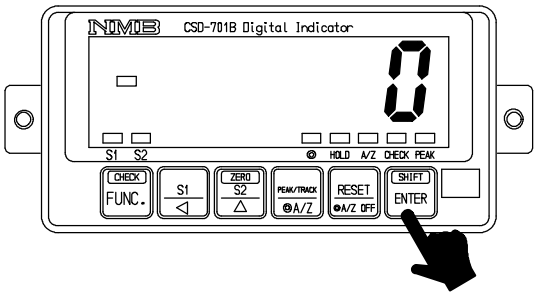

 key : Increase the analog output

Procedures								
5	<p>Fine adjustment on the maximum value of analog output</p> <p>Press the  key.</p> <p>The load display will flashing display showing "A_HI".</p>							
6	<p>Press the  key.</p> <p>The load display will flash on and off showing "A_HI".</p> <p>At the same time, the analog output equivalent to the maximum value of analog output will be obtained.</p> <p>Adjust so the output will become the maximum value with the right keys.</p> <table border="1" data-bbox="236 763 842 909"> <thead> <tr> <th></th> <th>Voltage output (Standard)</th> <th>Current output (Optional)</th> </tr> </thead> <tbody> <tr> <td>Maximum value</td> <td>5 V</td> <td>20 mA</td> </tr> </tbody> </table> <p> It can be increased continuously by the continuity press of the key.</p>		Voltage output (Standard)	Current output (Optional)	Maximum value	5 V	20 mA	 <p> key : Decrease the analog output</p> <p> key : Increase the analog output</p>
	Voltage output (Standard)	Current output (Optional)						
Maximum value	5 V	20 mA						
7	<p>Press the  key.</p> <p>The load display will show "END".</p> <p>By pressing the  key again, the Measurement mode can be returned through the VCAL mode, then the present load will be shown.</p> <p>At this moment, the result of fine adjustment on the minimum/maximum output of analog output can be renewed.</p>	 						





7-15-3. Fine adjustment 2 on analog output





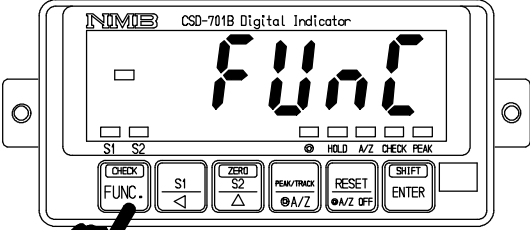

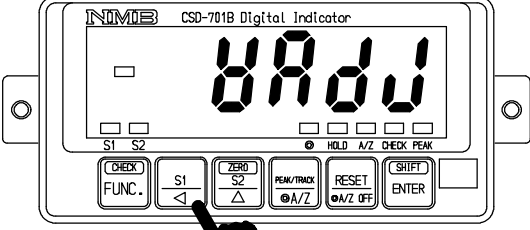
The fine adjustment explained in this paragraph is the procedures with applying the actual weight.

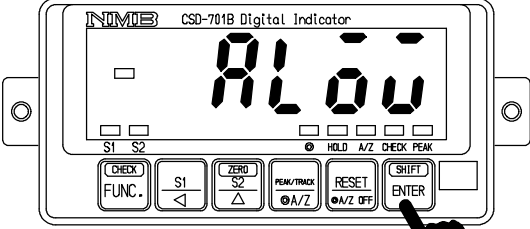
 **Warning** Before making the fine adjustment, be sure to make scaling for the analog output by referring to the paragraph 7-15-1. If neglected, deviation of output can't be adjusted during the fine adjustment.



 During the application on fine adjustment, if you want to suspend the fine adjustment, press the  key. The zero data, the span data are kept as they were before entering the fine adjustment, and the Measurement mode can be re-entered.

Please execute the fine adjustment after about one hour has passed since the power supply was turned on. The fine adjustment can be executed in the status of the stable or more.

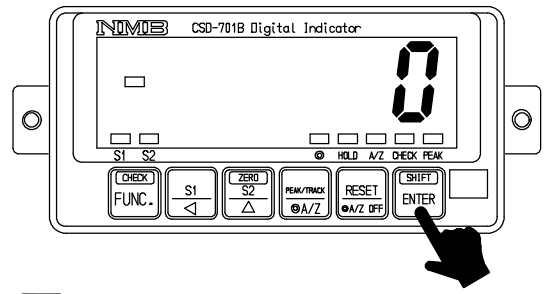

Procedures		
1	Press the  key for one second. The load display will show "FUNC".	
2	Press the  key 10 times. The load display will change as "FUNC" "CCAL" "ACAL" "LCAL" "ZERO" "SPAN" "TARE" "CHEK" "MONT" "VCAL" "VADJ".	
3	Press the  key. The load display will show "ALOW". At the same time, set the weight equivalent to the minimum output value of the analog output.	

Procedures	
<p>4</p>	<p>Press the  key. The load display will flash on and off showing the current load value. At the same time, adjust the deviation with the right keys so the analog output will meet with the actual weight.</p> <div data-bbox="231 392 837 504" style="border: 1px solid black; padding: 5px;">  It can be increased continuously by the continuity press of the key. </div>
<p>5</p>	<p>Fine adjustment on the maximum value of analog output Press the  key. The load display will show "A_HI". At the same time, set the weight equivalent to the maximum output value of the analog output.</p>
<p>6</p>	<p>Press the  key. The load display shows the current load value and flashes on and off. At the same time, adjust the deviation of analog output against the load with the right keys.</p> <div data-bbox="231 1075 837 1187" style="border: 1px solid black; padding: 5px;">  It can be increased continuously by the continuity press of the key. </div>
<p>7</p>	<p>Press the  key. The load display will show "END".</p> <p>By pressing the  key again, the Measurement mode can be returned through the VADJ mode, then the present load will be shown. At this moment, the result of fine adjustment on the minimum/maximum output of analog output can be renewed.</p>

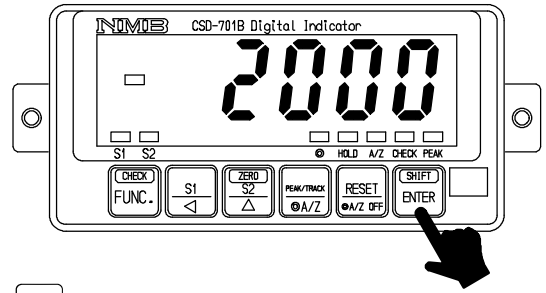
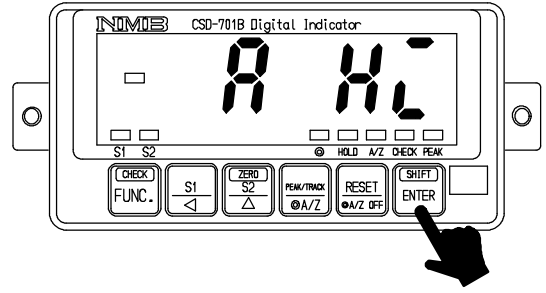

 key : Decrease the analog output
 key : Increase the analog output



 key : Decrease the analog output
 key : Increase the analog output

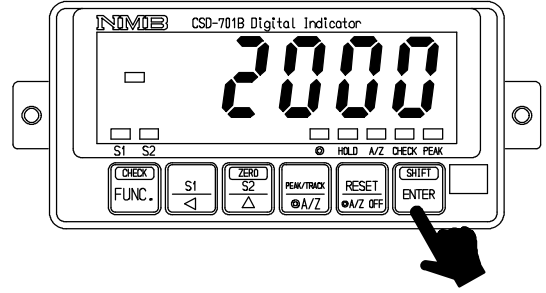
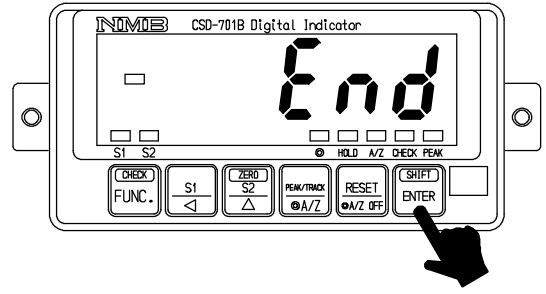

7-15-4. Selection of the target of analog output

The instrument can select the target of analog output from the “TRACK/gross load” and the “PEAK/Net weight”.

This selection can be made in the Function mode(Related function F-20).

Besides, during the “Gross/TRACK” is selected, the target of analog output will become normal “TRACK value” and normal “Gross weight” each, that is, at the time of selection of the “Peak function” with the Function F-70 and also the “A/Z function” is selected each.

7-16. Memory location for setting data and so on

In the instrument, each data is recorded in RAM and EEPROM as follows :

Data is preserved when almost permanent. because of nonvolatile EEPROM.

Moreover, because RAM is not backed up, RAM data disappears in power supply OFF.

① Data recorded in RAM

- A/Z data Data can clear with A/Z OFF.
- ZERO tracking data Data can clear by the F-98 execution.

② Data recorded in EEPROM

- FUNC data Data can be initialized by the F-99 execution.
- Calibration data Data can be rewritten by the re-calibration.
- Fine adjustment data for the analog output
 Data can be rewritten by the fine adjustment again.
- ZERO data Data can clear by the F-98 execution.
- Each set value for the comparator S0, S1 and S2
 Data can clear by the change in each set value.



The memory locations for the A/Z data and the ZERO data can be changed to whichever the “RAM” or the “EEPROM” with the setting Function F-71.

7-17. Prohibition of calibration

The instrument can set the prohibition of the calibration for the excessive calibration.

This setting can be made in the Function mode.

(Related Function F-97.) As for the default, “Possible to calibrate” has selected. The targets of prohibition are each calibration described in the Chapter 5, and each fine adjustment on the analog output described in the paragraph 7-15-2 and the paragraph 7-15-3.

When executing the calibration with the setting of Prohibition of calibration, the “ER-6” will be displayed.

7-18. Check mode

The following confirmations can be made in the Check mode.

- Check of ROM version
- Check of the mounting option
- Check of bridge voltage
- Check of the external control input
- Check of the contact output
- Check of the analog output
- Check of the BCD output (option)



The check on the BCD output will be operated only when the BCD output is installed.



The instrument can return to the Measurement mode by pressing the



key even in the halfway of the Check mode.

7-18-1. Operating procedure for the check mode











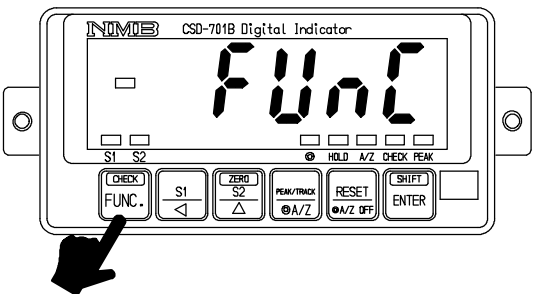

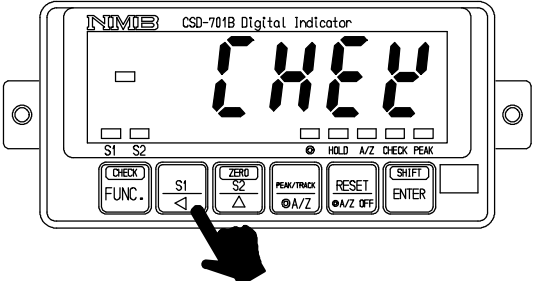

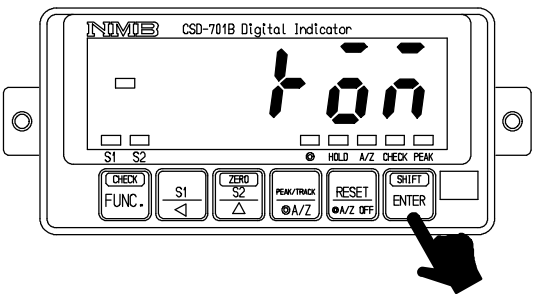
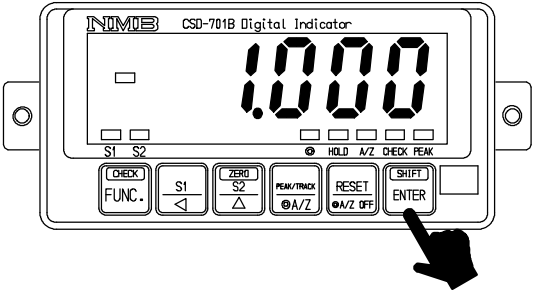

When the  key is pressed with the load display of “FUNC”, the display will change as the following arrow marks indicate at every time the key is pressed. However, every time the  key is pressed, the display will change as the reverse direction of the following arrow marks.

“FUNC” “CCAL” “ACAL” “LCAL” “ZERO” “SPAN”

“TARE” “CHEK” “MONT” “VCAL” “VADJ” “FUNC”

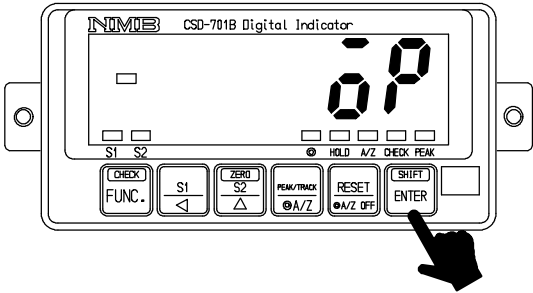
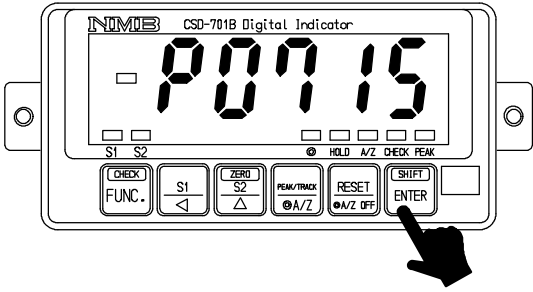
“CCAL” (Hereinafter over and over again.)

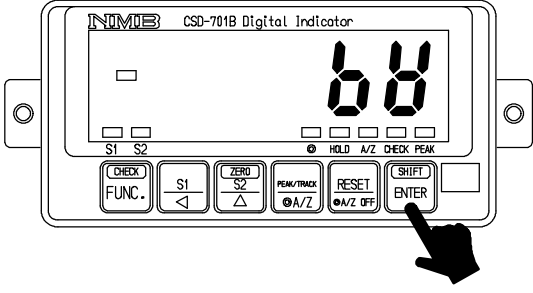
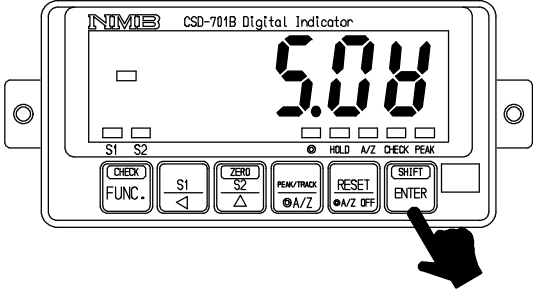
Procedures		
1	<p>Press the  key for one second. The load display will show "FUNC".</p>	
2	<p>Press the  key 7 times. The load display will change as "FUNC" "CCAL" "ACAL" "LCAL" "ZERO" "SPAN" "TARE" "CHEK".</p>	
3	<p>• Check of the ROM version</p> <p>Press the  key. The Check mode can be entered, and the display on the load display section will show "ROM". By pressing the  key again, the ROM version will be shown on the load display section.</p> <div style="border: 1px solid black; padding: 5px; margin: 10px 0;"> <p> In the Check mode, when the display on the load display section will be the one in the below, the display can be changed by the  key operation.</p> </div> <p>「ROM」 「OP」 「BV」 「IN」 「S-OUT」 「A-OUT」 「BCD」 「END」 「ROM」</p> <p> key :</p>	 

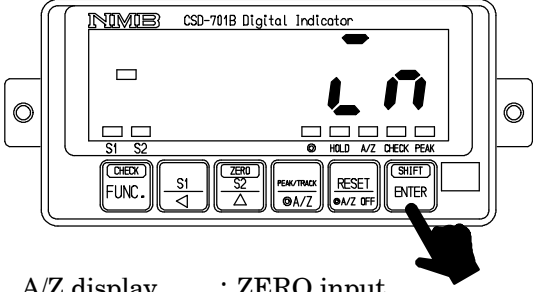
		Procedures											
4		<ul style="list-style-type: none"> • Check of the options <p>Press the  key. The load display will show “OP”.</p> <p>Check on bridge power supply voltage</p> <p>By pressing the  key again, the load display will show the optional number of the option installed at present on the load display. When no option is installed, the “P-----” will be appeared.</p>	 										
		<table border="1"> <thead> <tr> <th>Display</th> <th>Installed options</th> </tr> </thead> <tbody> <tr> <td>07</td> <td>Current output</td> </tr> <tr> <td>15</td> <td>BCD output</td> </tr> <tr> <td>74</td> <td>RS-232C interface</td> </tr> <tr> <td>76</td> <td>RS-422 interface</td> </tr> <tr> <td>77</td> <td>Serial interface</td> </tr> </tbody> </table>	Display	Installed options	07	Current output	15	BCD output	74	RS-232C interface	76	RS-422 interface	77
Display	Installed options												
07	Current output												
15	BCD output												
74	RS-232C interface												
76	RS-422 interface												
77	Serial interface												
5		<ul style="list-style-type: none"> • Check of the bridge power supply voltage <p>Press the  key. The load display will show “BV”.</p> <p>By pressing the  key again, the bridge power supply voltage selected at present will be seen on the load display section.</p>	 										
		<ul style="list-style-type: none"> • Check on the external control input <p>Press the  key. The load display will show “IN”.</p> <p>By pressing the  key again, the load display section will change into the “IN” flashing display.</p> <p>At the same time, the ON/OFF condition of external control input signal can be monitored on the Status display LED.</p>	 <p>A/Z display : ZERO input HOLD display : HOLD input PEAK display : PEAK/TRACK input display : RESET input</p>										

Procedures

• Check on the contact output

Press the  key.

The load display will show “S-OUT”.

By pressing the  key again, the load display will flash “-S0-”.

At the same time, by the operations of right keys, each judgement display for each contact output and the load display section will change as below :

「S1」

「S2」

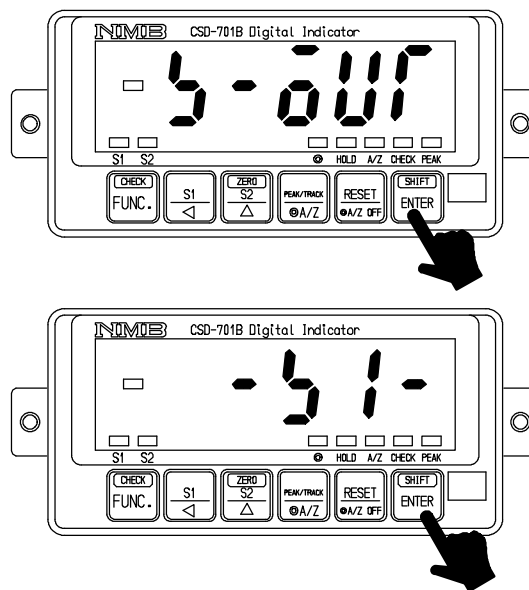

key : Each contact output is sequentially turned on from a left chart below.



key : Each contact output is sequentially turned on from the left chart under up.

S1 display : S1 output

S2 display : S2 output

• Check on the analog output

Press the  key.

The load display will show “A-OUT”.

By pressing the  key again, display will show “LOW” and also flashes on and off.

At this moment the analog output will output the value equal to the “LOW” value shown in the below table.

Every time  key is pressed, the display will change as the arrow marks indicate, and also the analog output will change as shown in the below table.

「LOW」

「MID」

「HIGH」

Display	Standard (Voltage output)	Option (Current output)
LOW	0 V	4 mA
MID	2.5 V	12 mA
HIGH	5 V	20 mA



The output values here reflect the values adjusted in the paragraph 7-15-2, and 7-15-3.

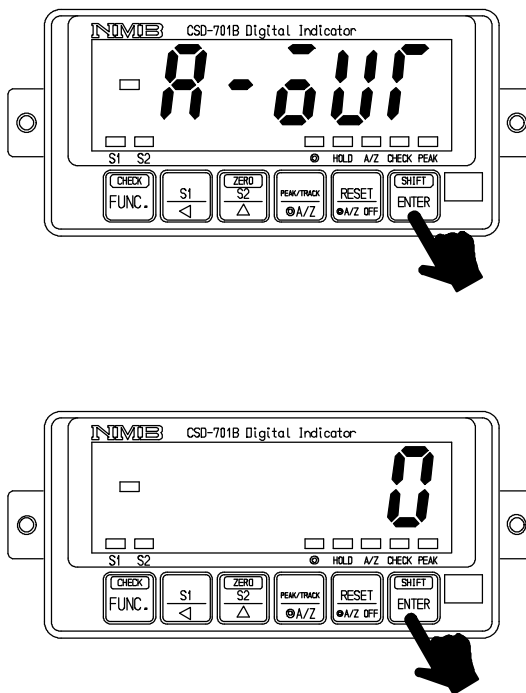







key : The analog output is sequentially switched from a left chart below.

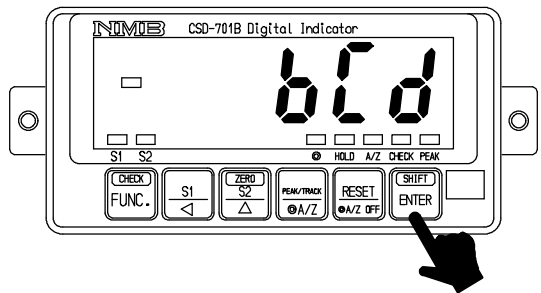

key : The analog output is sequentially switched from a left chart under up.

7

8

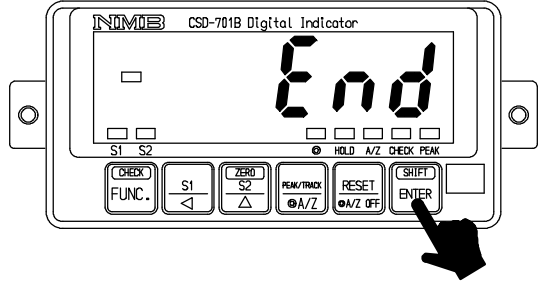
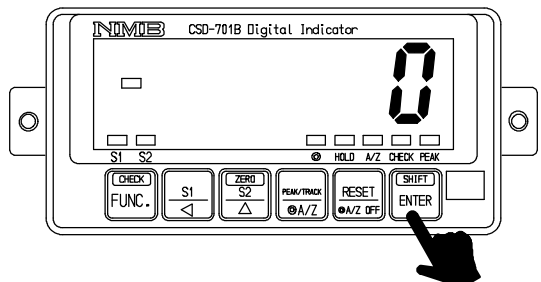
Procedures		
<p>9</p>	<p>• Check of the BCD output</p> <div style="border: 1px solid black; padding: 5px; margin-bottom: 10px;">  In case that the BCD output isn't installed, shift to the step 10. </div> <p>Press the  key. The load display will show "BCD".</p> <p>By pressing the  key again, the display will show "00000" and the digit of 10⁰ flashes on and off.</p> <p>At this moment, the same value as the display will output from the BCD output. When changing the display with the right keys, the BCD output will change corresponding to it.</p>	 <p> key : Set value carry key</p> <p> key : Set value inclement key</p>
<p>10</p>	<p>Press the  key. The load display will show "END".</p> <p>By pressing the  key again, it will over the Check mode and returns to the Measurement mode to show the load value.</p>	 

7-19. Monitor mode

In the Monitor mode, the applied load on the strain gage applied transducer at present can be displayed with the converted unit to mV/V.



For example, in case that the load cell is used, and its output value is unclear, apply actual load in order to read the output value at the time of initial load application and also at the time of the maximum load application by using the function and then make calibration with the obtained value as a base.





The display value in the Monitor mode is a reference value.



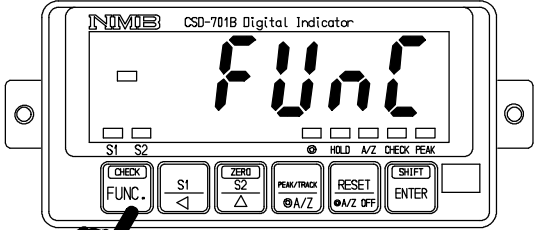

The accuracy of display is 0.5 % approximately.

In the Monitor mode, the range which can be monitored is from
- 0.5 mV/V to 3.1 mV/V approximately.

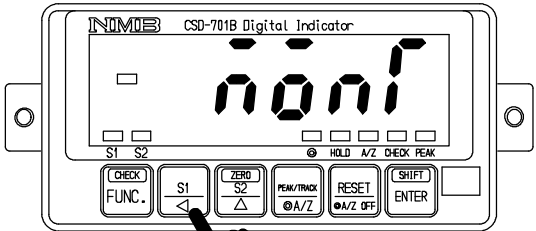
When the  key is pressed with the load display of “FUNC”, the display will change as the following arrow marks indicate at every time the key is pressed. However, every time the  is pressed, the display will change as the reverse direction of the following arrow marks.

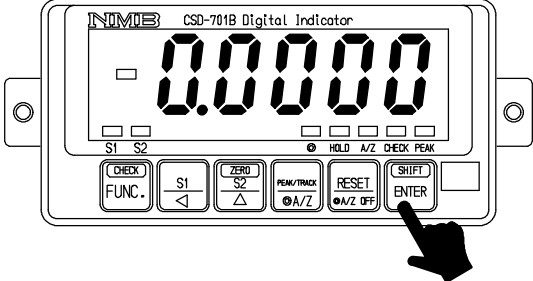
“FUNC” “CCAL” “ACAL” “LCAL” “ZERO” “SPAN”
“TARE” “CHEK” “MONT” “VCAL” “VADJ” “FUNC”
“CCAL”... (Hereinafter, over and over again.)

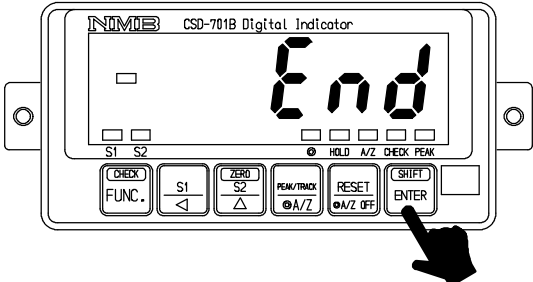
Procedures		
1	Press the  key for one second. The load display will show “FUNC”.	
2	Press the  key 8 times. The load display will change as “FUNC” “CCAL” “ACAL” “LCAL” “ZERO” “SPAN” “TARE” “CHEK” “MONT”.	

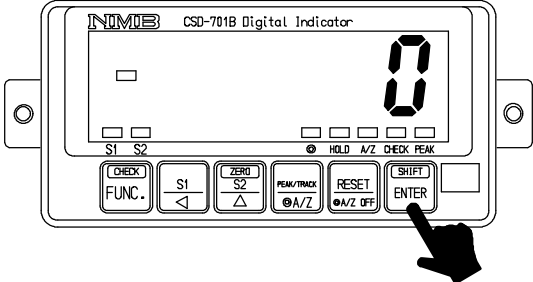



Procedures		
3	Press the  key. The Monitor mode can be entered, and the converted value into mV/V for the present input value for the transducer will flash on and off on the load display.	
4	Press the  key. The load display will show "END".	
5	Press the  key. The Monitor mode can be over, and the present load is shown on the load display.	





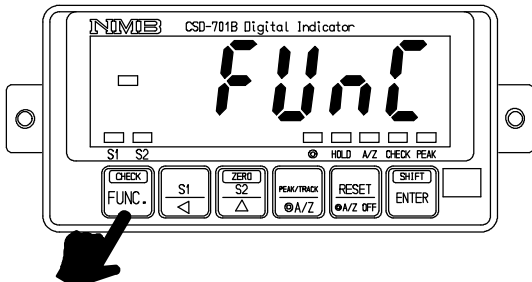

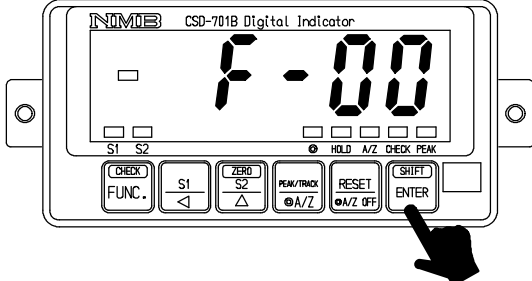

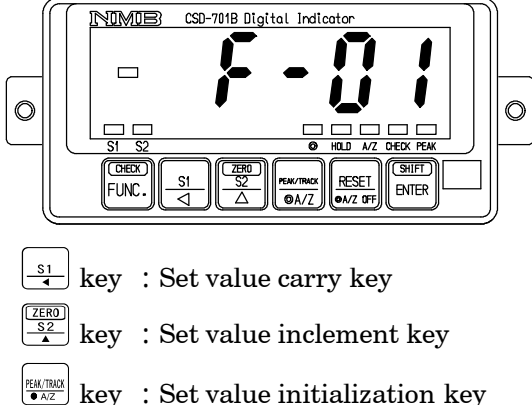

8. Function mode

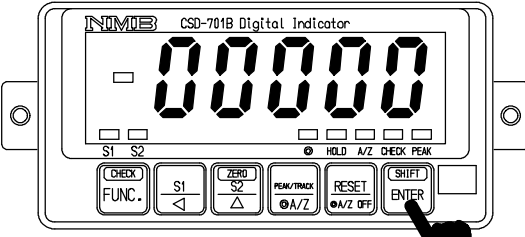
 **Warning** During the Function mode, the instrument suspends measurement. In due course, even when input of strain gage applied transducer may change, various kinds of outputs will not change, which may cause destruction in equipment due to malfunction in peripheral equipments.

 When the display is treated as a target of HOLD (F-10), the Function mode can't be entered with the condition of inputting the HOLD signal. Before entering Function mode, be sure to cancel the input of HOLD.

8-1. Setting method for function mode

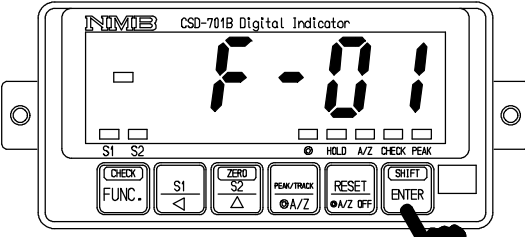
	Procedures	
1	Press the  key for about one second. The load display will show "FUNC".	
2	Press the  key. Function mode can be entered, then the load display will show "F-***", and the digit of 10^0 will flash on and off. The last called Function No. is shown at **. Suspend the setting of Function mode, then press the  key when returning to the Measurement mode is required.	
3	Select the Function No. desired to set with the right keys. Suspend the setting of Function mode, then Measurement mode can be re-entered by pressing the  key. <div data-bbox="119 1724 726 1836" style="border: 1px solid black; padding: 5px; margin-top: 10px;">  It can be increased continuously by the continuity press of the key. </div>	

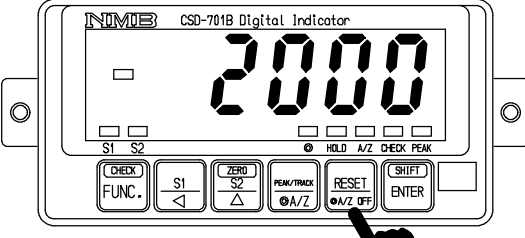
Procedures		
<p>4</p>	<p>Press the  key. Content of setting Function that has selected will be displayed and the digit of 10⁰ will flash on and off. Change the setting with the right keys.</p> <p>Press the  key to suspend the setting of Function mode, then return to the measurement mode.</p> <div style="border: 1px solid black; padding: 5px; margin-top: 10px;">  It can be increased continuously by the continuity press of the key. </div>	 <p> key : Set value carry key</p> <p> key : Set value inclement key</p> <p> key : Set value initialization key</p>
<p>5</p>	<p>Press the  key. The set contents are registered, then the load display will return to the registered Function No., and the 10⁰ digit will flash on and off.</p> <p>Press the  key. Setting another Function No. is desired, return to step 3.</p>	
<p>6</p>	<p>Press the  key. Quitting the Function mode, the Measurement mode can be returned.</p>	

8-2. Function of Function data

- F-01 Selection of decimal point at display position

Initial value = 00000 00000 = Non

00001 = 10^1

00002 = 10^2

00003 = 10^3

00004 = 10^4

- F-03 Selection of display rate

Initial value = 00000 00000 = 4 times/s

00001 = 20 times/s



- F-04 Setting digital filter



Initial value = 00003 Setting range : = 00000 ~ 00008, Average of $2^{(n)}$ times



Select the average times for digital filter. When the figure grows larger, the filter will become stronger, then effects from vibrations and so on are shown scarcely on the display. However, if too large figure is selected, the response to variation of input sensor will become worse.



Using the digital filter where vibrations and so on may exist is effective for removing the deflection on the display.

- F-06 Setting key lock

Initial value = 00000 10^0 digit : ON/OFF of CHECK value (Press the  key in the condition of pressing  key.)

10^1 digit : ON/OFF of Peak Hold function, A/Z ON () ,
Reset of the peak value, A/Z OFF ()

10^2 digit : Reading out the change mode of S1 setting () ,
Reading out the change mode of S2 setting ()

10^3 digit : Execute the zero setting (Press the  key in the condition of pressing the  key.)

10^4 digit : Reading out the function mode ()

The setting of "0" makes the lock OFF of key function, and the setting of "1" makes the lock ON of key function. Moreover, when the reading out the function mode is

locked, the function mode can be proceeded after pressing the  key for over 2

seconds in the condition of pressing the  key for over 1 second.

- F-08 Setting zero tracking data width

Initial value = 00000 00000 = Zero tracking OFF

Setting range : 00000 ~ 00099

Unit : 0.5D







Data width of 49.5D with the setting "00099".

Effective only when the value of 00001 ~ 00099 is set with the F-07.

- F-20 Setting the target of analog output
 Initial value = 00000 00000 : TRACK/Gross weight
 00001 : PEAK/Net weight
- F-21 Display value at the time of the minimum analog output
 Initial value = 00000 Setting rage - 99999 ~ 99999
- F-22 Display value at the time of the maximum analog output
 Initial value = 02000 Setting rage - 99999 ~ 99999
- F-30 Setting comparator operation
 Initial value = 00011 0 = OFF
 1 = ON
 10⁰ digit : Comparator S1
 10¹ digit : Comparator S2
- F-31 Setting the target of comparator
 Initial value = 00000 0 = TRACK/Gross weight
 1 = Synchronous with display
 10⁰ digit : Comparator S1
 10¹ digit : Comparator S2
- F-32 Setting the direction of comparator
 Initial value = 00000 0 = Greater or equal
 1 = Less or equal
 10⁰ digit : Comparator S1
 10¹ digit : Comparator S2
- F-34 Setting the condition of Hysteresis operation for comparator
 Initial value = 00001 00000 = ON delay
 00001 = OFF delay
- F-35 Setting the hysteresis data width for comparator
 Initial value = 00000 00000 = Hysteresis data width OFF
 Setting rage : 00000 ~ 00099
 Unit : 1D
 Data width of 99D at the setting of "00099".
- F-36 Setting Hysteresis time width for comparator
 Initial value = 00000 00000 = Hysteresis time width OFF
 Setting rage : 00000 ~ 00099
 Unit : 0.1 s
 Data width of 9.9 s at the setting of "00099"
- F-40 Setting the target of BCD output(Effective when the option is installed.)
 Initial value = 00000 00000 = TRACK/Gross weight
 00001 = PEAK/Net weight
- F-41 Setting the logic of BCD output (Effective when the option is installed.)
 Initial value = 00000 00000 = Negative logic
 00001 = Positive logic

- F-55 Setting the terminator of RS-232C/RS-422
 (Effective when the option is installed.)
 Initial value = 00001 00000 : CR
 00001 : CR+LF
- F-56 Setting the decimal point of sending code of RS-232C/RS-422
 (Effective when the option is installed.)
 Initial value = 00000 00000 : No decimal point
 00001 : Yes of Decimal point
- F-57 Setting the ID number of RS-422(Effective when the option is installed.)
 Initial value = 00000 Setting range : 00000 ~ 00031
- F-70 Changing Peak function / A/Z function
 Initial value = 00000 00000 : Effective in the Peak function
 00001 : Effective in the A/Z function
- F-71 Setting the area of ZERO, A/Z and stored data
 Initial value = 00001 0 = RAM
 1 = EEPROM
 10¹ digit : A/Z data
 10⁰ digit : ZERO data

 Selects whether the data at the time of ZERO A/Z will be recorded at the EEPROM or not. In case that the high frequency of use of ZERO, A/Z and A/Z OFF, the durability times will be over, so set "0". The durability times for the EEPROM will be approx. one million times.
- F-88 Selection of serial interface operation mode
 (Effective when the option is installed.)
 Initial value = 00000 00000 = Stream
 00001 = Stream + Automatic print
 00002 = Stream + Manual print
- F-90 Increment value (For reference)
 The increment value set when the calibration is applied can be referred to.
 The setting can't be changed in the function.
- F-91 The maximum display value (For reference)
 The maximum display value set when the calibration is applied can be referred to.
 The setting can't be changed in the function.
- F-92 The actual load value (For reference)
 The actual load value set when the calibration is applied(LCAL) can be referred to.
 When the calibration except LCAL is made, this value will not change.
 The setting can't be changed in the function.
- F-93 Zero calibration value (For reference)
 The input voltage value that has read as the initial load value at the time of executing calibration can be referred to.
 The setting can't be changed in the function.
- F-94 Span calibration value (For reference)
 The input voltage value at the time of the maximum display can be referred to.
 The setting can't be changed in the function.

- F-97 Prohibition of calibration
Initial value = 00000 00000 = Possible to calibrate
00001 = Prohibition from calibration
- F-98 ZERO clear
Zero compensated data by zero set function can be cancelled.
When the  key is pressed with “F-98” displayed, “ZCLR” can be displayed.
(At the same time, the display lights on and off.)
At this point, press the  key when suspending the ZERO clear is desired.
Measurement mode can be returned and Zero clear will not be executed.
When the  key is pressed while “ZCLR” display lights on and off, “F-98” display can be returned. Now, ZERO clear has completed.
- F-99 Memory clear
Setting from F-01 to F-97 recorded at EEPROM will return to the default value.
When the  key is pressed with the display of F-99, then “FCLR” display can be obtained. (At the same time, the display lights on and off.) At this point, press the  key when suspending memory clear is desired. Measurement mode can be returned and Memory clear will not be executed.
When the  key is pressed during “FCLR” load display lights on and off, and after about 1 second, it will become “F-00” display and the operation of Memory clear has completed.



Warning

Never use the following functions because they may destroy the functions at internal of the instrument.

F-00	F-02	F-05	F-07	F-13	F-14	F-18	F-19
F-23	F-24	F-25	F-26	F-27	F-28	F-29	F-33
F-37	F-38	F-39	F-46	F-47	F-48	F-49	F-58
F-59	F-60	F-61	F-62	F-63	F-64	F-65	F-66
F-67	F-68	F-69	F-72	F-73	F-74	F-75	F-76
F-77	F-78	F-79	F-80	F-81	F-82	F-83	F-84
F-85	F-86	F-87	F-89	F-95	F-96		

9. Options

The options for the instrument are as follows:

- | | |
|-----------------------------------|-------------------------|
| ① Current output[DC4 mA to 20 mA] | Parts No. : CSD701B-P07 |
| ② BCD output | Parts No. : CSD701B-P15 |
| ③ RS-232C interface | Parts No. : CSD701B-P74 |
| ④ RS-422 interface | Parts No. : CSD701B-P76 |
| ⑤ Serial interface | Parts No. : CSD701B-P77 |
| ⑥ Power supply voltage DC12 V | Parts No. : CSD701B-P66 |
| ⑦ Power supply voltage DC24 V | Parts No. : CSD701B-P67 |

For the options from ② to ⑦, there is a limitation in the combinations as shown in the table below. Moreover, the selection shall be made whichever one of the options of ④ or ⑤.

	P07	P15	P74	P76	P77
P07	-				
P15		-	×	×	×
P74		×	-	×	×
P76		×	×	-	×
P77		×	×	×	-

: Available, × : Unavailable

9-1. Current output



Refer to the paragraph 4-3-5, for the connecting method, and refer to the paragraph 7-15, for their applications.

9-1-1. Related functions

F-20	Setting of analog output target	TRACK/Gross weight and PEAK/Net weight
F-21	Indicated value at the minimum value of analog output	Indicated value at the output of approx. 4 mA
F-22	Indicated value at the maximum value of analog output	Indicated value at the output of approx. 20 mA.

9-1-2. Specifications for the current output

Parts No. CSD701B-P07

- | | | |
|---------------------|------------|--|
| (1) Output | Output | : DC4 mA to 20 mA |
| | Over range | : Approx. 0 mA at the display “ - OL”
Approx. 24 mA at the display “OL” |
| (2) Load resistance | | : 260 Ω or less |
| (3) Non-linearity | | : 0.05 %F.S. |
| (4) Resolution | | : Approx.1/10 000 |
| (5) Output rate | | : Synchronous with the display rate (4 times/s, 20 times/s) |

9-2. BCD output



Warning

When power is ON for the instrument with the external HOLD signal shorted, the BCD output will be as follows:

- ① Even when the Display is targeted for the HOLD with the F-10, BCD outputs “00000” if the target for BCD output is set as Display.
- ② When the BCD output is assumed to be the target of HOLD with the F-10, BCD output outputs “00000”.
- ③ Other than the case above and , the present load value will output after “00000” has output.

In other than the Measurement mode, the BCD output will not be renewed. In due course, the “ERROR” for the BCD output won’t be ON in other than the mode of the Measurement mode, so care should be taken fully.

When the CHECK switch is applied, pay attention to the following point. By the ON operation of CHECK, the “OL” error display (BCD output is OVR.) might be shown.

9-2-1. Related function

F-40	Setting the target of BCD output	TRACK/Gross weight, PEAK/Net weight
F-41	Setting output logic for BCD data	Negative logic, Positive logic
F-42	Setting output logic for BCD polarity	Negative logic, Positive logic
F-43	Setting output logic for BCD flag	Negative logic, Positive logic
F-44	Setting output logic for BCD P.C.	Negative logic, Positive logic
F-45	Setting the width of BCD P.C.	25 ms, 125 ms

9-2-2. Specifications for BCD output

(1) Output logic

Relative function Negative logic, Positive logic can be changeable by the related functions F-41, F-42 and F-43.

(2) Output data

BCD 5 digits parallel output
POL. (Polarity) ON at minus, and output OFF at plus.
P.C. (Print command)
ERROR
OVR. (Over)

(3) Input data

BCD-ENABLE Compulsive OFF for the related output with BCD
(High-impedance)

(4) Output target

Change of TRACK/gross weight, change of PEAK/Net weight can be available with the related function F-40.

(5) Output times

Synchronous with the display times (F-03) 4 times/s, 20 times/s, 100 times/s

9-2-3. Pin configurations for the BCD output connector

1	COM.	14	1×10^3	27	N.C.
2	1×10^0	15	2×10^3	28	N.C.
3	2×10^0	16	4×10^3	29	N.C.
4	4×10^0	17	8×10^3	30	N.C.
5	8×10^0	18	1×10^4	31	N.C.
6	1×10^1	19	2×10^4	32	N.C.
7	2×10^1	20	COM.	33	N.C.
8	4×10^1	21	4×10^4	34	N.C.
9	8×10^1	22	8×10^4	35	BCD-ENABLE.
10	1×10^2	23	POL.	36	N.C.
11	2×10^2	24	OVR.	37	N.C.
12	4×10^2	25	ERROR		
13	8×10^2	26	PC.		

Suitable plug : Equivalent to DC-37P-NR made by JAE



Never connects with the N.C. pins.

9-2-4. Equivalent circuit for input/output

(1) Equivalent circuit for input

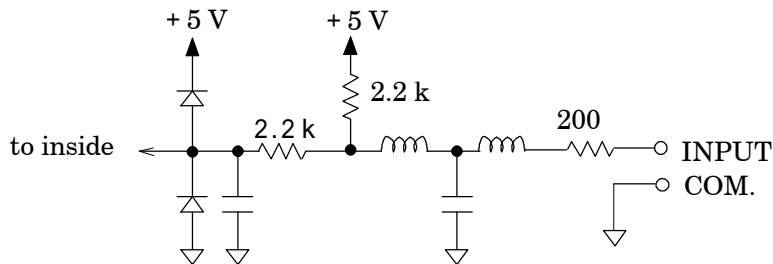

(2) Equivalent circuit for output

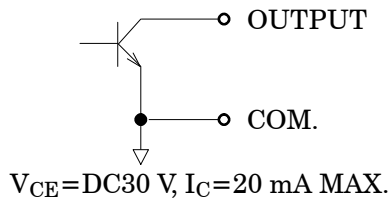

9-2-5. Timing chart



Warning

In case of reading each output data of the BCD output through the sequencer and so on, read them at the timing of “The edge from ON to OFF” for the P.C. (Print command). Moreover, read the “Input response delay time” for the reading instrument such as a sequencer and so on, with full considerations. If neglected, there may have the possibility that correct reading of data won’t be obtained.

(1) Normal

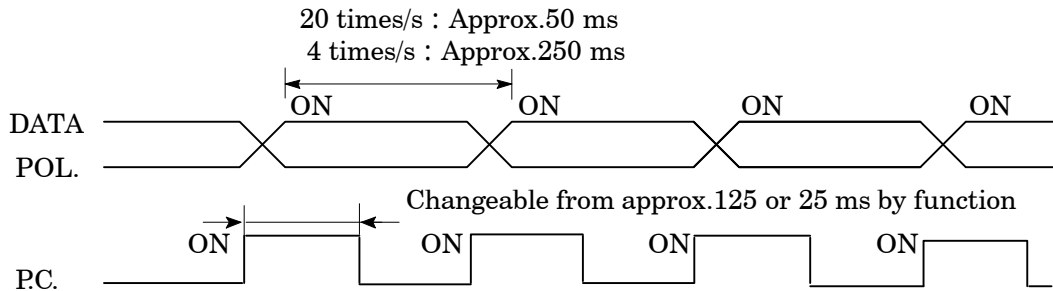

At the time of data output of each P.C., DATA and POL., output transistor will become ON(Negative logic electrically).

(2) When the data is over-ranged

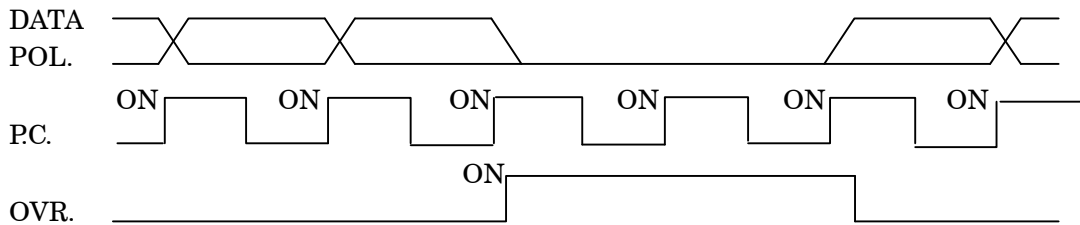

At the time of OVR output, output transistor will at the OVR signal will become ON(Negative logic electrically). Moreover, for all of the DATA, output transistor will become OFF (Positive logic electrically) at the time of OVR output. (However, for the POL., normal OFF at the “OL”, and normal ON at the “ - OL”.

(3) When ERROR is occurred

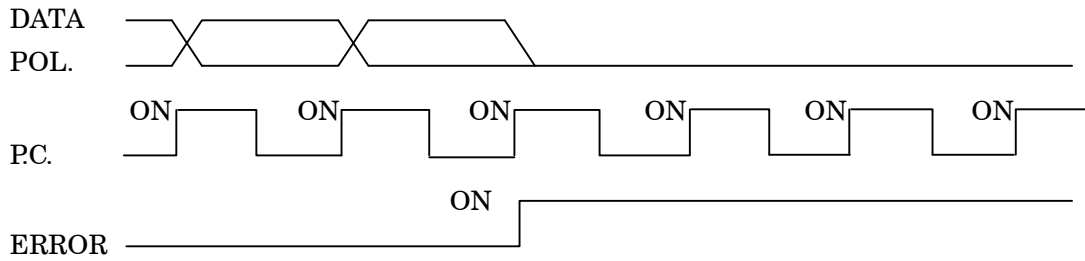

At the time of ERROR output, output transistor at ERROR signal will become ON(Negative logic electrically). Moreover, for each DATA, POL., all of the output transistor will become OFF at the time of ERROR output(Positive logic electrically).

(4) When the HOLD signal is input

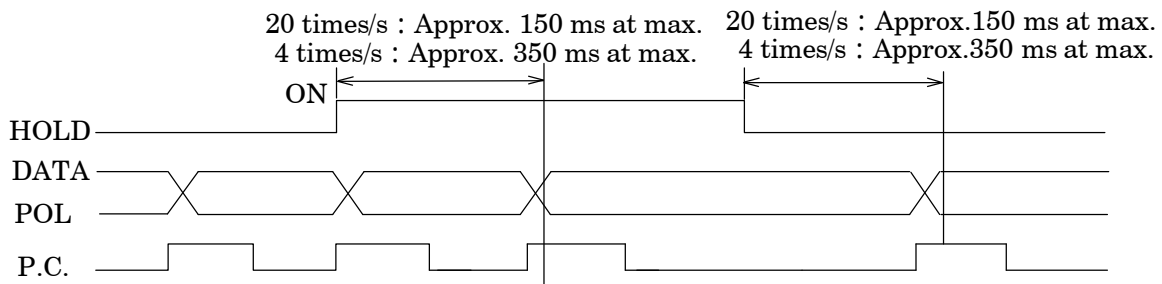

At the time of HOLD signal input, output transistor for the P.C. will be OFF condition. (Positive logic electrically.)(However, for P.C.,OFF condition will be made after one(1) shot of operation.)

After inputting the HOLD signal, it takes the following response times to freeze the DATA, POL or cancellation of HOLD is executed.

At the time of 20 times/s : Approx.150 ms at maximum

At the time of 4 times/s : Approx.350 ms at maximum

9-2-6. Output condition

Setting output logic	Output data	Condition of transistor	Pin-COM level at the time of voltage supply externally.
Negative logic	Yes	ON	L
	No	OFF	H
Positive logic	Yes	OFF	H
	No	ON	L

9-2-7. Selection of output logic for P.C.(Print command), and selection of its width

Selection of the P.C. logic for BCD output, and its width can be made by setting function. (Related function : F-44, F-45)

Select the P.C. width to meet with the display rate set by F-03, and execute the suitable selection according to the following list.

Display rate (F-03)	P.C. width	
	Approx.125 ms	Approx.25 ms
4 times/s		
20 times/s	×	

: Possible to use, × : Impossible to use.(P.C. output doesn't operate correctly.)



Warning

The selection of P.C. width should be made adequately according to the display times set with the F-03. If neglected, the P.C. output will not operate correctly.

9-3. RS-232C interface



Warning

In other than the mode of Measurement mode, such as in Function mode, Calibration mode, Fine adjustment mode and Setting mode, the Error command will be send against the command from the Host.

When the CHECK switch is applied, pay attention to the following points.

- ① By ON operation of the CHECK, the instrument isn't in the Measurement mode anymore, however RS-232C interface responses to the command from the host.
- ② By ON operation of the CHECK, "OL" error display might be shown. At this time, when reading command for load is executed, the "OL" will be transferred to the host.

9-3-1. Related function

F-50	Setting the operation mode	Stream mode or Command mode
F-51	Setting the output target at the time of stream mode	TRACK/Gross weight or PEAK/Net weight
F-52	Setting the baud rate	1 200, 2 400, 4 800, 9 600 or 19 200 bps
F-53	Setting data bit length & parity	Parity bit : Non, Even parity or Odd parity Data length : 7 bit or 8 bit
F-54	Setting the stop bit	1 bit or 2 bit
F-55	Setting the terminator	CR or CR+LF
F-56	Setting decimal point for sending code	No or Yes



Setting of this function makes the setting activated immediately after setting.

9-3-2. Specifications for interface

- (1) Method Conforms to RS-232C.
- (2) Communication method Half duplex
- (3) Specifications for signal

Baud rate	1 200, 2 400, 4 800, 9 600, 19 200 bps
Data length	7 bit or 8 bit
Parity bit	Non, Even parity or Odd parity
Stop bit	1 bit or 2 bit
Terminator	CR or CR + LF
Synchronous method	Start-stop synchronous method
Transmission data	ASCII code
- (4) Input/Output monitor with LED

9-3-3. Procedures of data transfer

There are two kinds of data transfers in the instrument, that is, stream mode and command mode.

(1) Stream mode

The latest targeted data targeted/selected with the F-51 keep on outputting. However, output times will change depending on the setting of display times and baud rate.

(2) Command mode

By sending the determined command/data from the host (Personal computer, sequencer and so on) to the CSD-701B, the data will be send back to the host side from the CSD-701B corresponding to the command/data.

Be sure to execute communication according to the below procedures.

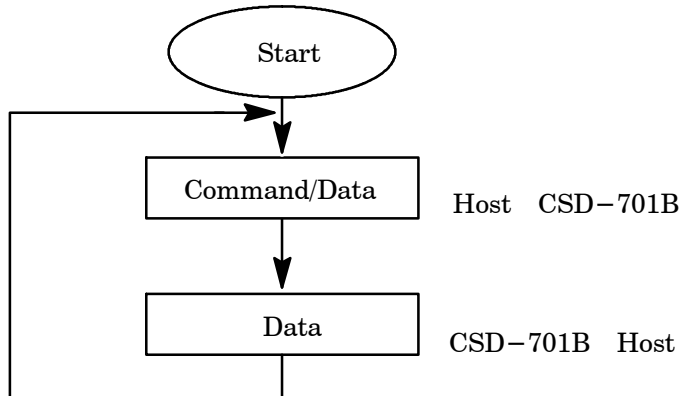

The communication operation can be made in all of the modes. However, in the Function mode, Calibration mode, Fine adjustment mode and Setting mode, the Error command will be sent.

The flow control is not executed in the CSD-701B.

The CTS/RTS signal isn't applied.

The X flow control isn't performed.

The operating communication is a conversational dialogue type.

9-3-4. Pin configurations for connector pin

(1) Pin configuration

Pin No.	Signal Name
1	CD
2	TXD
3	RXD
4	N.C.
5	S.G.
6	N.C.
7	RTS
8	CTS
9	N.C.

Suitable plug : Equivalent to DE-9S-NR made by JAE Not attached.



The screws for the fixing base of plug at the connector of RS-232C interface is inch type thread.

(2) Example of connection at the RS-232C interface

① Example 1

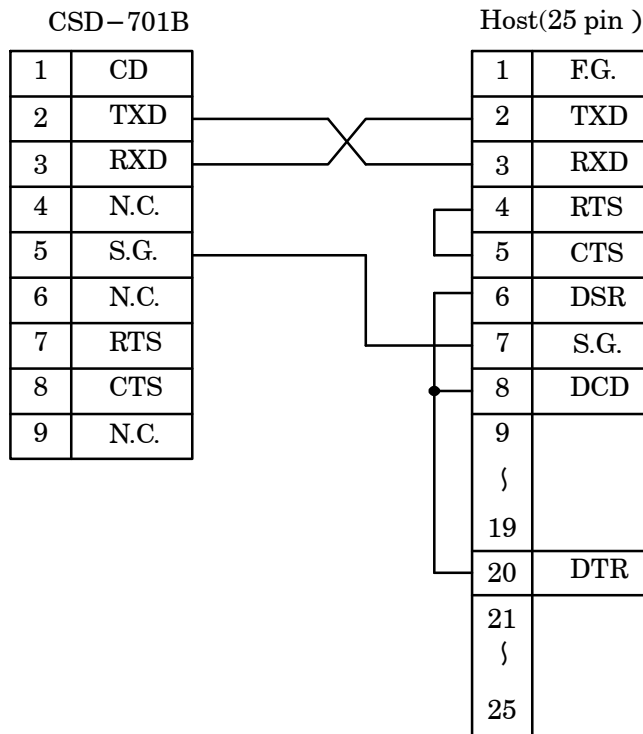

(2) Command mode

① Reading out the load data(Host 701B)

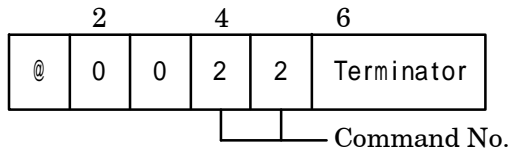

Command No.	Operation
21	Reading out TRACK/Gross weight
22	Reading out the display data

Return(CSD-701B Host)

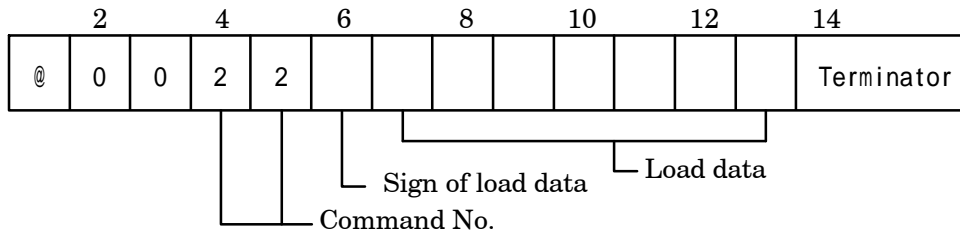

- The load data enters from the right end.
- When the data is minus, “ - ” sign and when plus, “ + ” sign is added.
- Load weighing data performs zero suppress.
- In case that the decimal point is set with the F-56, and at the same time the decimal point is specified with the F-01, it will be added to the specified position.
- The message will be output at the time of overloaded.
- The empty sections are all spaces.

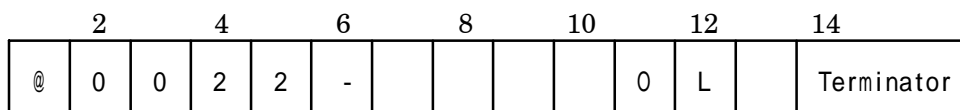
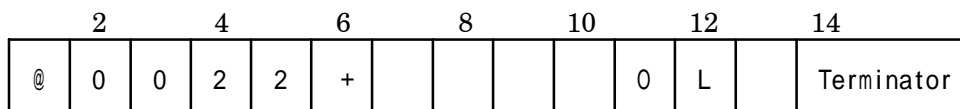
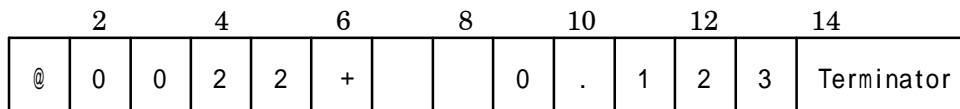
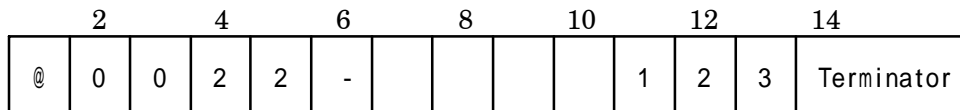

② Reading out the comparative data (Host CSD-701B)

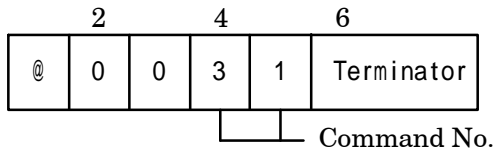

Command No.	Operation
31	Reading out S1 data
32	Reading out S2 data

Return(CSD-701B Host)

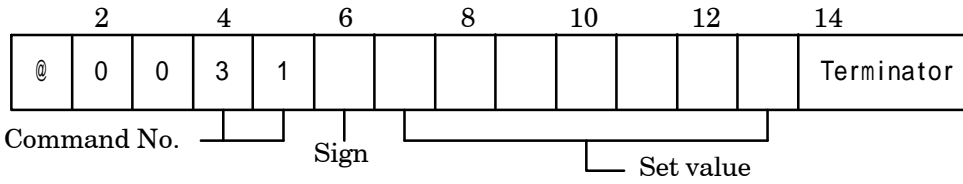

- The load data enters from the right end.
- When the data is minus, “ - ” sign and when plus, “ + ” sign is added.
- The sign data performs zero suppress.
- In case that the decimal point is set with the F-56, and at the same time the decimal point is specified with the F-01, it will be added to the specified position.

③ Writing comparative data(Host CSD-701B)

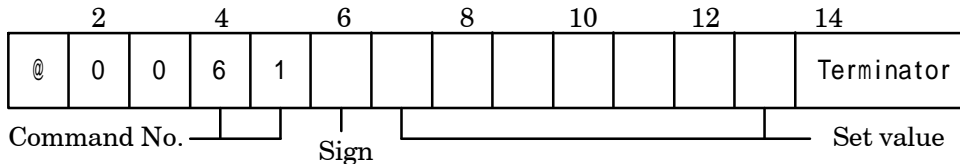

Command No.	Operation
61	Writing the S1 data
62	Writing the S2 data

Return(CSD-701B Host)

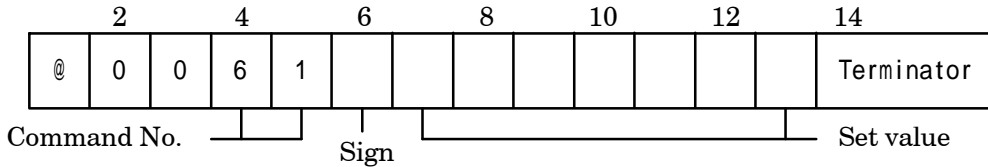

- The set value enters from the right end.
- Setting range is from - 99 000 to 99 999.
- Never add the decimal point.

9-3-6. Communication error process

The instrument returns the error command to the host side at the time of Communication error or Execution error.

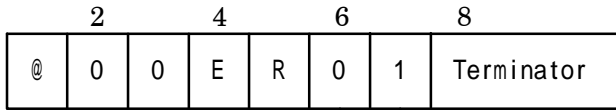

└──┬──┘ Error Command No.

Error Command No.	Contents	Remarks
01	Error of impossible condition of execution	In the case of Function mode, Calibration mode, Fine adjustment mode and Setting mode.
02	Another error caused from the instrument	In the case of impossible to execute the receiving command.
10	Parity error	In the case of detecting the parity error.
11	Framing error	In case of detecting error for stop bit.
12	Overrun error	In the case of reading error for receiving command.
13	Error of data code, data length error	The receiving data code and data length are not the same.
14	No applicable command	The receiving command isn't the same.



In case that the Completion code (terminator) is not detected, the error code will not be returned.

In case that the communication error command is returned from the instrument, consider its remedy at the host side.

9-4. RS-422 interface



Warning

The error code will be sent against the command from the host during other than the mode of Measurement mode, such as in the Calibration mode, Fine adjustment mode, and Setting mode.

When CHECK switch is ON status, take care of the following points.

- ① When CHECK switch will be ON status, the instrument will be out of the Measurement mode, but RS-422 interface will make response to the command from the Host.
- ② By ON operation of CHECK, there may be a case that display will show as “OL” error. At the same time, executing the reading command for load makes the “OL” transmitted to the Host.

The sending terminal is low impedance for 1 ms after finishing sending in the instrument. Therefore, to prevent from competing with other instruments, apply the sending wire (SDA, SDB) at the intervals of 1ms or more.

9-4-1. Related functions

F-52	Setting baud rates	1 200, 2 400, 4 800, 9 600 or 19 200 bps
F-53	Setting a data bit length and a parity bit length	Parity bit : Non, Even and Odd parity Data length : 7 bit, 8 bit
F-54	Setting a stop bit	1 bit, 2 bit
F-55	Setting the terminator	CR, CR+LF
F-56	Setting the decimal point in transmitting code	Non, Exist
F-57	Setting the ID No.	0 ~ 31



The setting of this function will be effective immediately after setting the function.

9-4-2. Specifications on interface

- (1) Method Conforms to RS-422.
- (2) Communication method Half-duplex
- (3) Specifications on Signal
 - Baud rate 1 200, 2 400, 4 800, 9 600 or 19 200 bps
 - Data bit length 7 bit, 8 bit
 - Parity bit None, Even and Odd parity
 - Stop bit 1 bit, 2 bit
 - Terminator CR or CR + LF
 - Synchronous method Start-stop synchronous method
 - Communication data ASCII code
 - Address 00 to 31
- (4) Cable length Approx.1 km
- (5) Number of connections 10 sets at maximum
- (6) Termination Built-in (Selecting the presence by the connection with terminal.)
- (7) Input/output monitor With LED (Existing on the PC. board at rear side of terminal board.)

9-4-3. Procedure of data transmission

By sending the determined command/data from the host (personal computer, sequencer and so on) to the CSD-701B, data will be sent back to the host side from CSD-701B corresponding to the command/data. Be sure to execute communication according to the below procedures.

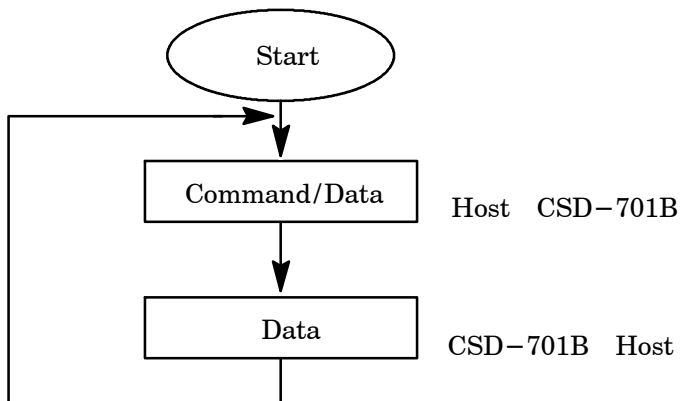

The communicating operation can be made in all of the modes. However, the error command will be transmitted in the Function mode, Calibration mode, Fine adjustment mode and the Setting mode. The flow control is not executed in the CSD-701B. The CTS/RTS signal isn't applied. The X flow control isn't performed. The communication operation is a conversational type.

9-4-4. Pin layout and wiring of Connector

(1) Pin configuration

SDA	Differential output (+)
SDB	Differential output (-)
RDA	Differential input (+)
RDB	Differential input (-)
TRM.	Terminator
S.G.	Signal ground



The TRM. is a terminal resistance. Connect the terminal resistance by shorting between the TRM. and RDM. at the last end of the host looking from the host (personal computer, sequencer and so on).

For the connection, we recommend to apply twisted pair wires.

(2) Example of connection

① 1 to 1

RS-422

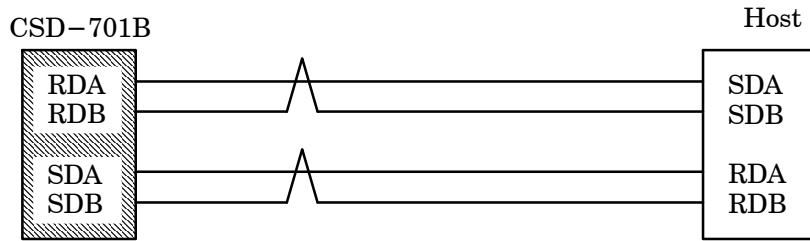

Connect the terminal resistance at the  section.

② 1 to n

RS-422

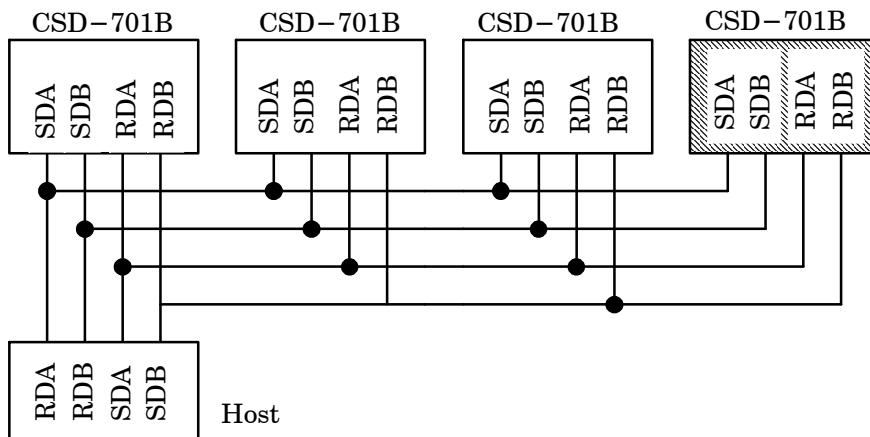

Connect the terminal resistance at the  section.

9-4-5. Data format

(1) Command mode

① Reading out the load data(Host CSD-701B)

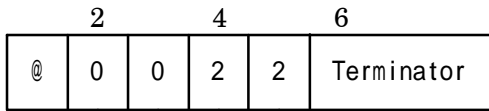

Command No.	Operation
21	Reading out the TRACK data
22	Reading out the PEAK data

ID No. 00 ~ 31
Command No.

Return(CSD-701B Host)

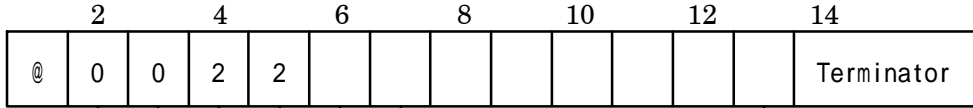

ID No. 00 ~ 31
Command No.
Sign of load data
Load data

- The comparative data enters from the right end.
- When the data is minus, “ - ” sign and when plus, “ + ” sign is added.
- The sign data perform zero suppress.
- When the decimal point is set with the F-56 and at the same time the decimal point is determined with the F-01, it will be added to the specified position.
- The message will be output at the time of overload.
- The empty sections are all spaces.

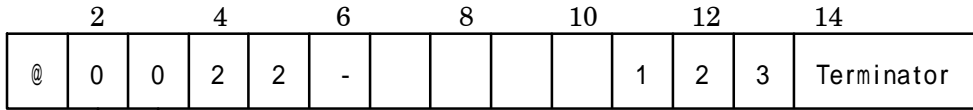

ID No. 00 ~ 31

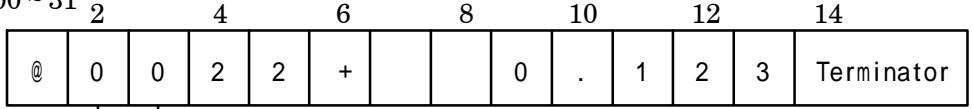

ID No. 00 ~ 31

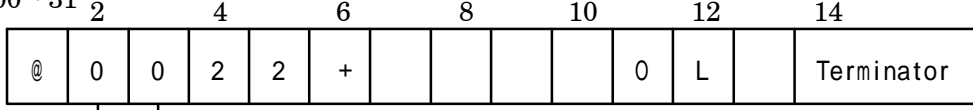

ID No. 00 ~ 31

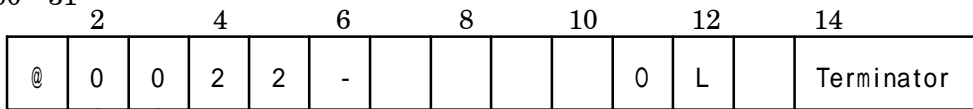

ID No. 00 ~ 31

② Reading-out the comparative data (Host CSD-701B)

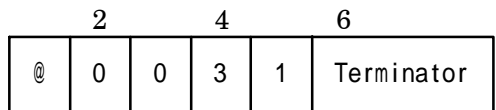

ID No. 00 ~ 31
Return(CSD-701B Host)

Command No.	Operation
31	Reading out S1 data
32	Reading out S2 data

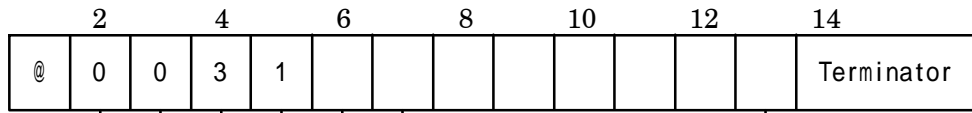

ID No. 00 ~ 31
Command No.

- The comparative data enter from the right end.
- When the data is minus, “ - ” sign and when plus, “ + ” sign is added.
- The sign data perform zero suppress.
- When the decimal point is set with the F-56 and at the same time the decimal point is determined with the F-01, it will be added to the specified position.
- The empty sections are all spaces.

③ Writing comparative data (Host CSD-701B)

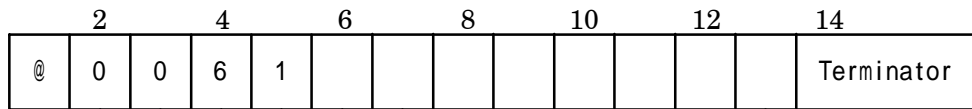

ID No. 00 ~ 31
Command No.

Command No.	Operation
61	Writing S1 data
62	Writing S2 data

Return(CSD-701B Host)

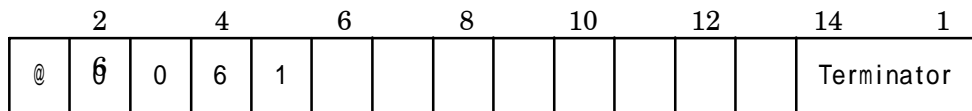

ID No. 00 ~ 31
Command No.

- The comparative data enters from the right end.
- The setting range is within - 99 999 to 99 999.
- Don't add a decimal point.

9-4-6. Process of communication error

The instrument sends back the error command to the host side at the time of occurrence of communication error or executing error.

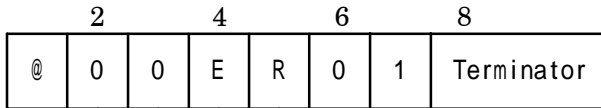

ID No. Error Command No.

00 ~ 31

Error Command No.	Contents	Remarks
01	Error of status of impossible to execute	During the Function mode, Calibration mode, Fine adjustment mode and Setting mode.
02	Another error caused from the instrument	In the case of impossible to execute the receiving command.
10	Parity error	In the case of detecting the parity error.
11	Framing error	In case of detecting error for stop bit.
12	Overrun error	In the case of reading error for receiving command.
13	Error of data code, data length error	The receiving data code and data length are not the same.
14	No applicable command	The receiving command isn't the same.



In case that the ID number and the Completion code (terminator) is not detected, the error command will not be returned.

In case that the communication error command is returned from the instrument, consider its remedy at the host side.

9-5-3. Connecting method and internal equivalent circuit

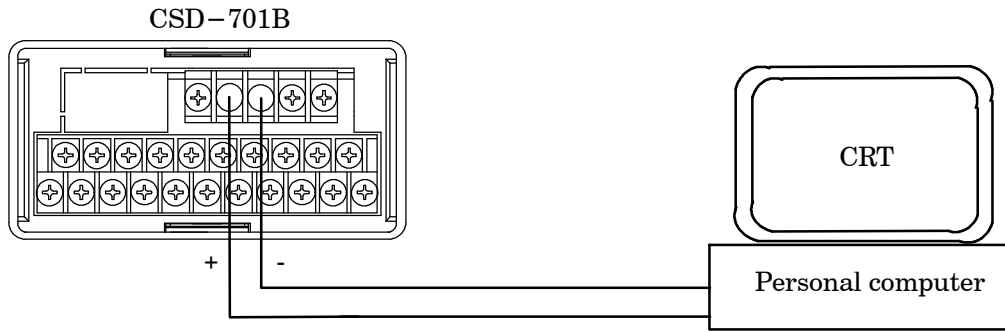

Corresponding instrument for serial interface, there are M250 Printer made by UNIPULSE Corporation and so on.

As for cable, be sure to use 2-cores shielded wire as much as you can. When shielded wire is not applied, make the cable twisted. (Cable length is within 100 m when shielded wire is applied, and within 20 m when shielded wire isn't applied.)

Corresponding instruments for serial interface can be connectable up to 3 sets in parallel. (Depending on the instruments connected. Maximum output current is approx. DC20 mA).

Internal equivalent circuit for CSD-701B

Corresponding instruments to serial interface.

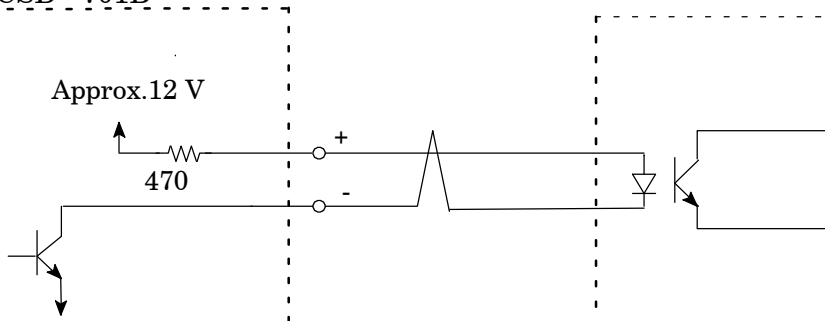

9-5-4. Data format

	1	2	3	4	5	6	7	8	9	10	11	12	13	14	15	16	17
INTERVAL	F1	F2	F3	LEN	FUN1	FUN2	ST1	ST2	CVR	ERR	G1	G2	G3	N1	N2	N3	BCC

- ① INTERVAL Mark signal for more than 15 bits(25 ms)
- ② F1 ~ F3 0FFH code
- ③ FUN1 Print command
- ④ FUN2 00H code
- ⑤ ST1 00H code
- ⑥ ST2 00H code
- ⑦ ST2 00H code
- ⑧ OVR 00H code
- ⑨ ERR Condition
- ⑩ G1 ~ G3 GROSS data
- ⑪ N1 ~ N3 NET data
- ⑫ BCC Calculated result from LEN to N3

(1) FUN1

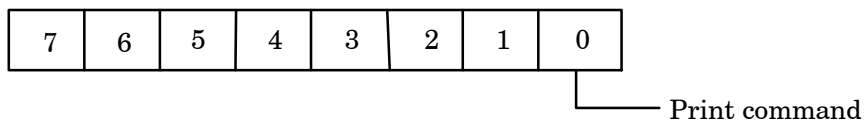

(2) ST1

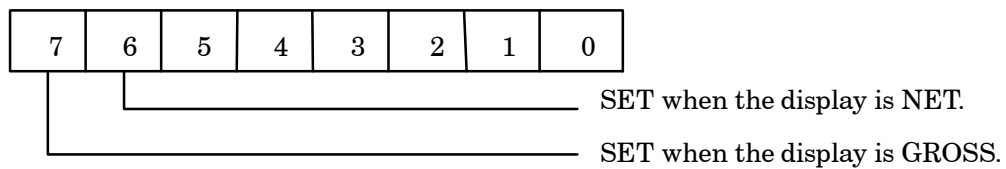

(3) GROSS data / NET data

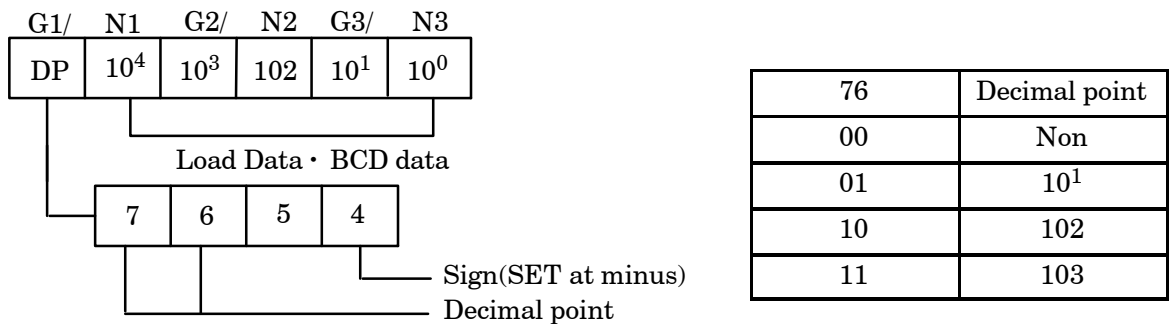

Output of serial data is executed only during Measurement mode.

9-5-5. Explanation of format data

(1) Automatic printing bit [FUN1 : bit 0]

This bit is applied for trigger through the receiving instrument for serial interface.

(2) Bit for display target [ST1 : bit 7, bit 6]

bit 7 : Set as "1" when the display of the instrument shows Gross weight.

bit 6 : Set as "1" when the display of the instrument shows Net weight.

9-5-6. Explanation of output type

(1) Stream mode

Gross weight data and Net weight data and so on keep outputting with a constant intervals.

(2) Automatic print mode

When the status of S1 and S2 output varies to OFF, the automatic print bit of output format FUN1 is set in "1" and transmitted.



Automatic print bit is "0" normally.

(3) Manual printing mode

When the HOLD signal varies from open condition to short(From OFF to ON), set the automatic printing bit to "1" for output format FUN1, and send it.



Warning

When automatic printing mode is selected, exclude the option from the target for HOLD. If you neglect, operations of setting the automatic printing bit to "1" and operation of sending it will not be executed.



Automatic printing bit is "0" normally.

9-6. Power supply voltage DC12 V(CSD701B-P66)

9-6-1. Layout of the terminal boards

There is one terminal board containing 21 point of terminals in the panel.

Layout of terminal boards when the power supply voltage is DC12 V are shown in the following figure. :

① Terminal board (21P)

Terminal No.	Descriptions	Applications	Terminal No.	Descriptions	Applications
1	A	Strain gage applied transducer	11	PEAK/TRACK or A/Z	External control input
2	B		12	RESET or A/Z OFF	
3	C		13	COM.2	Contact output
4	D		14	S1	
5	E		15	S2	
6	A-OUT +	Analog output	16	F.G	Frame ground
7	A-OUT -		17	SOURCE	DC0 V power supply
8	COM.1	External control input	18	N.C.	
9	ZERO		19	SOURCE	DC + 12 V power supply
10	HOLD		20	N.C.	
			21		Ground



The COM.1(Terminal No.8) and COM.2(Terminal No.13) are isolated.

Please refer to clause 4-2 for notes concerning connecting wires.

The power supply is DC12 V(DC10 V to DC15 V).

9-6-2. Connection with the power supply and the earth

Connections with the power supply and the earth should be made as the following figure.
Grounding should be the D class with single earth.

Power supply voltage DC12 V (Allowable variable range : DC10 V to 15 V)
Power consumption Approx.3.6 W (at DC12 V)

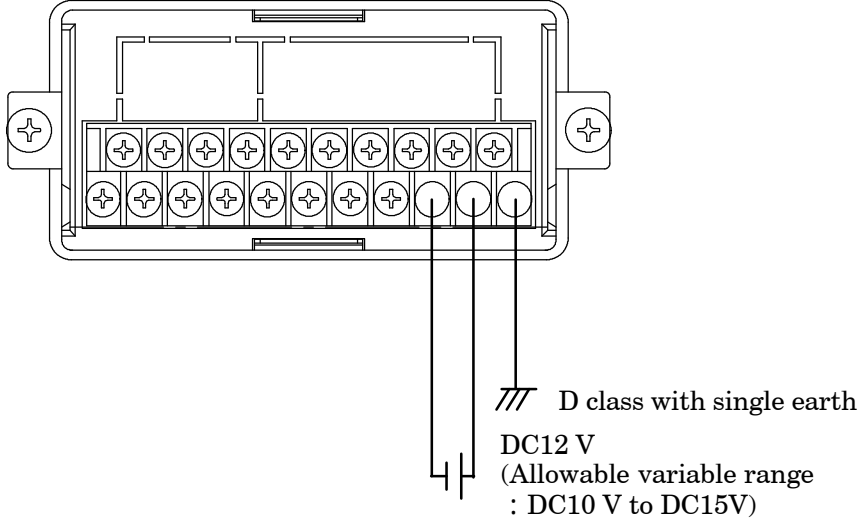

 **Warning** Connections with the power supply and the earth should be made securely according to the figures and also within the rated capacity of the instrument. If neglected, it may cause an unexpected cause of failure.

 Grounding should be the D class with single earth.
If neglected, it may cause an unexpected malfunction due to the effects of noise from other equipments.

9-7. Power supply voltage DC24 V(CSD701B-P67)

9-7-1. Layout of the terminal boards

There is one terminal board containing 21 point of terminals in the panel.

Layout of terminal boards when the power supply voltage is DC24 V are shown in the following figure. :

① Terminal board (21P)

Terminal No.	Descriptions	Applications	Terminal No.	Descriptions	Applications
1	A	Strain gage applied transducer	11	PEAK/TRACK or A/Z	External control input
2	B		12	RESET or A/Z OFF	
3	C		13	COM.2	Contact output
4	D		14	S1	
5	E		15	S2	
6	A-OUT +	Analog output	16	F.G	Frame ground
7	A-OUT -		17	SOURCE	DC0 V power supply
8	COM.1	External control input	18	N.C.	
9	ZERO		19	SOURCE	DC + 24 V power supply
10	HOLD		20	N.C.	
			21		Ground



The COM.1(Terminal No.8) and COM.2(Terminal No.13) are isolated.

Please refer to clause 4-2 for notes concerning connecting wires.

The power supply is DC24 V(DC20 V to DC30 V).

10. Trouble shooting

Please check the instrument according to the following procedures when abnormality is found in busy and operation. Moreover, please contact with MINEBEA when there is no corresponding item, and the symptom does not disappear even if the solution is done.

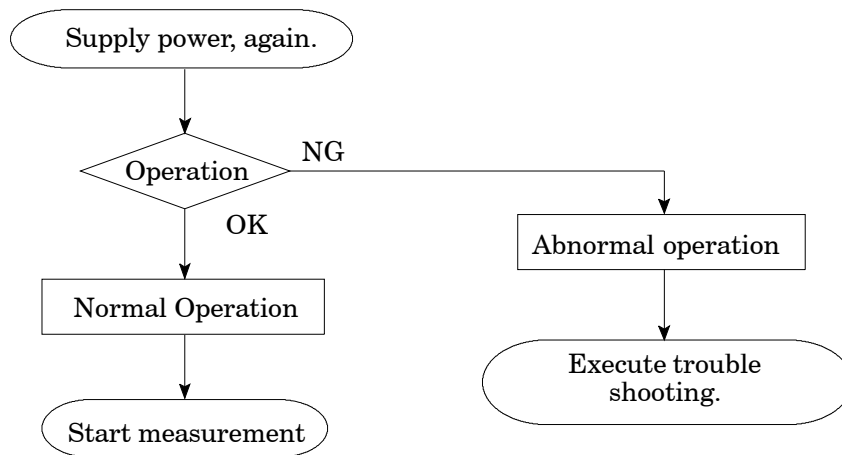

10-1. Execute trouble shooting

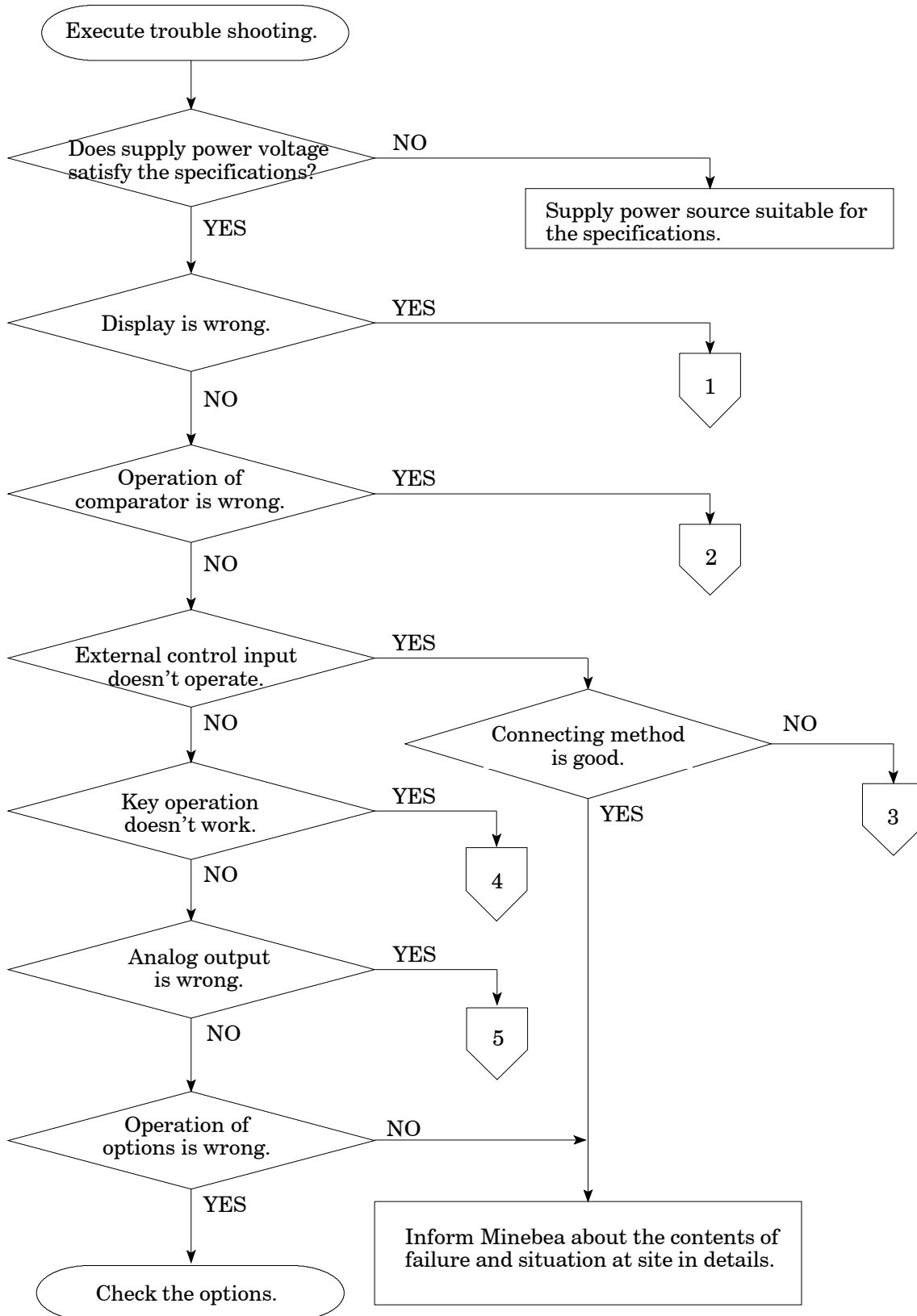

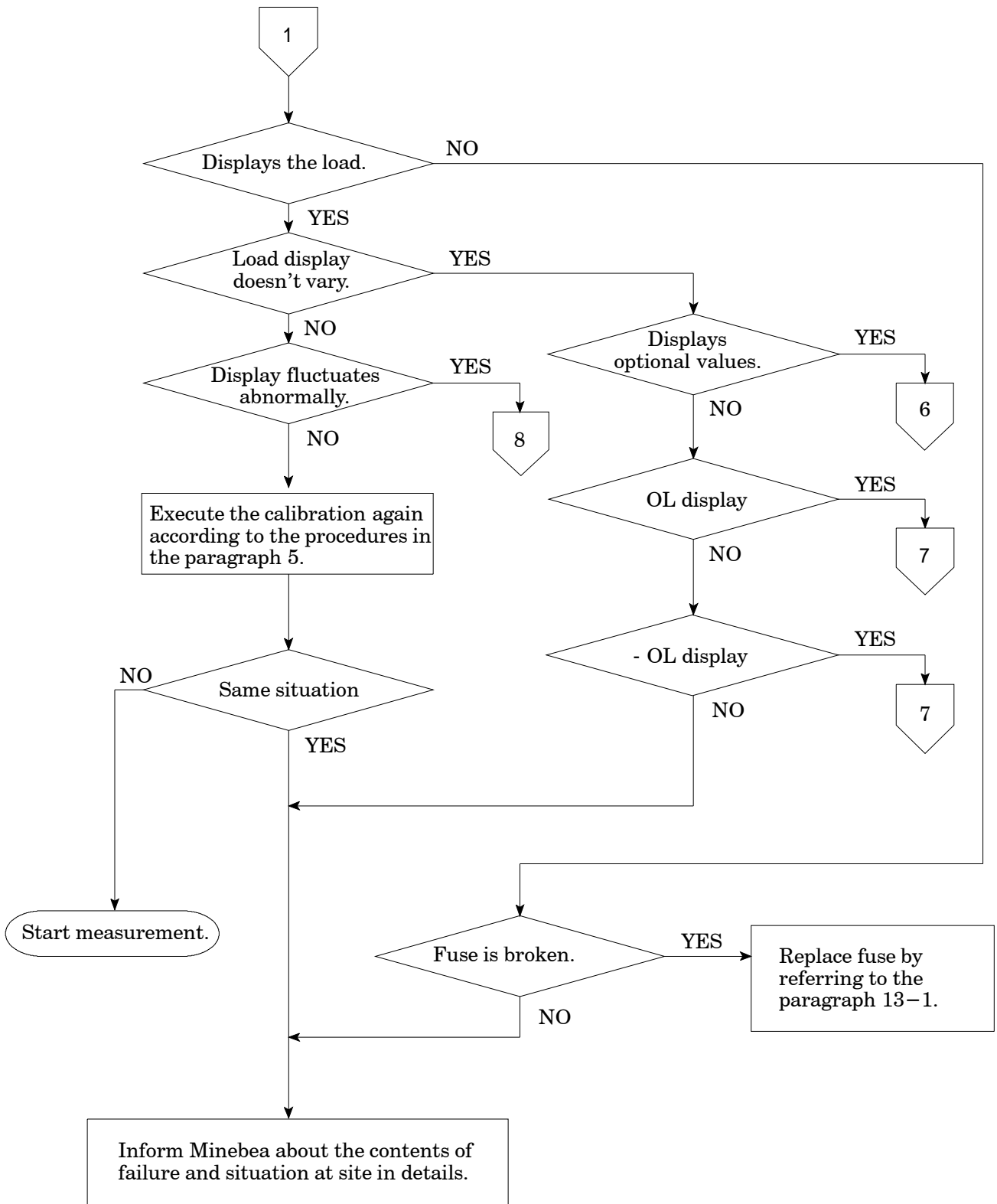

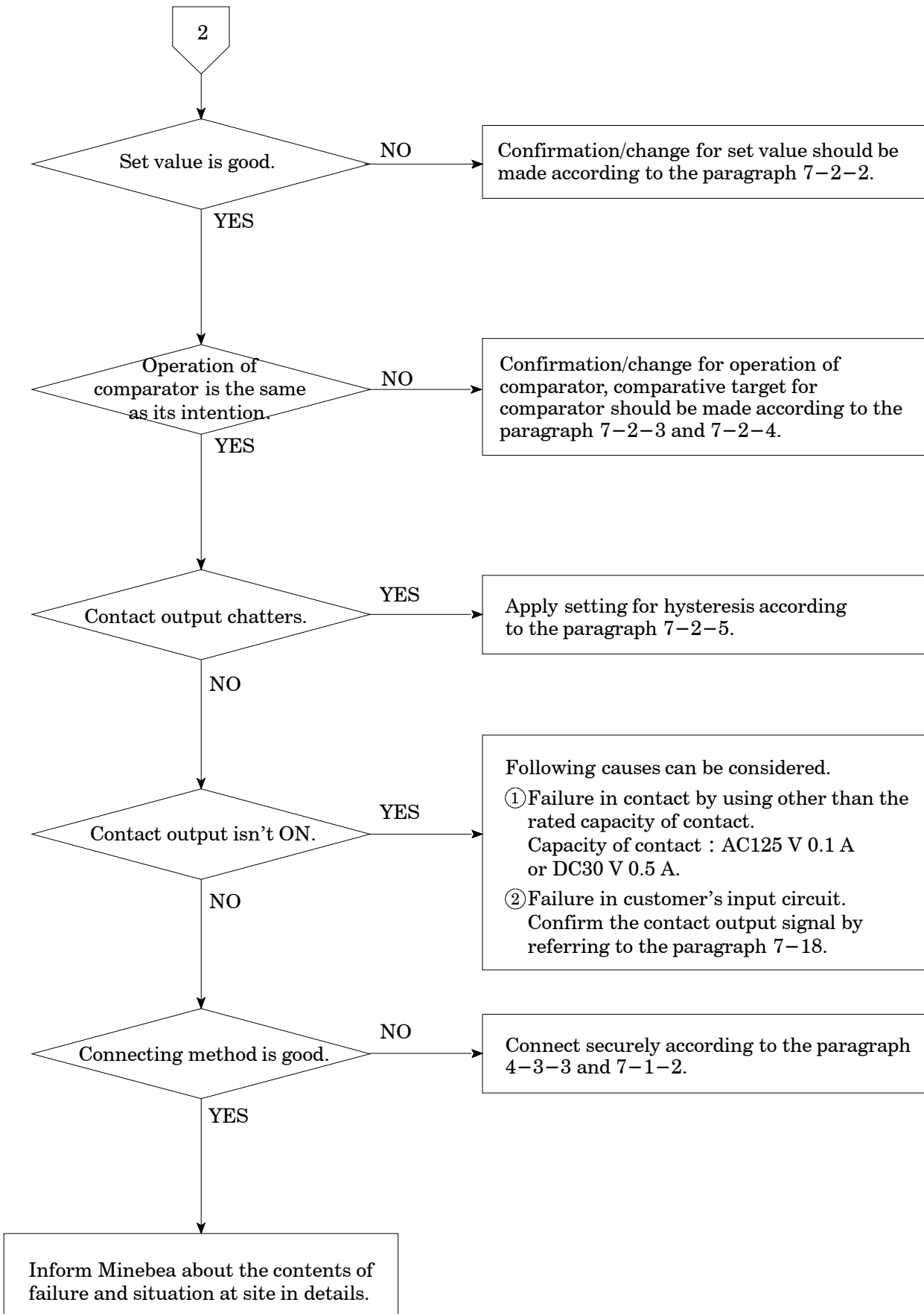

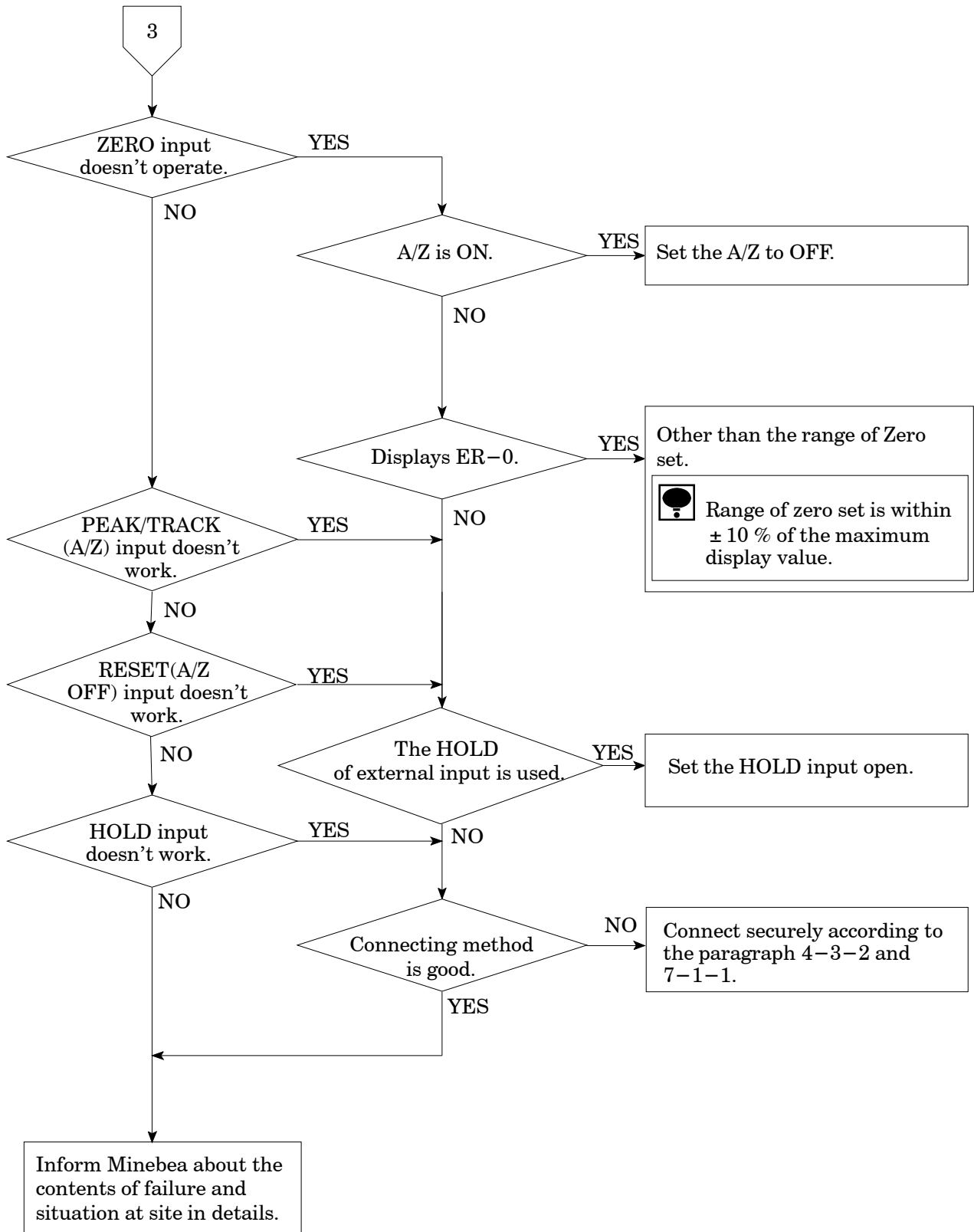

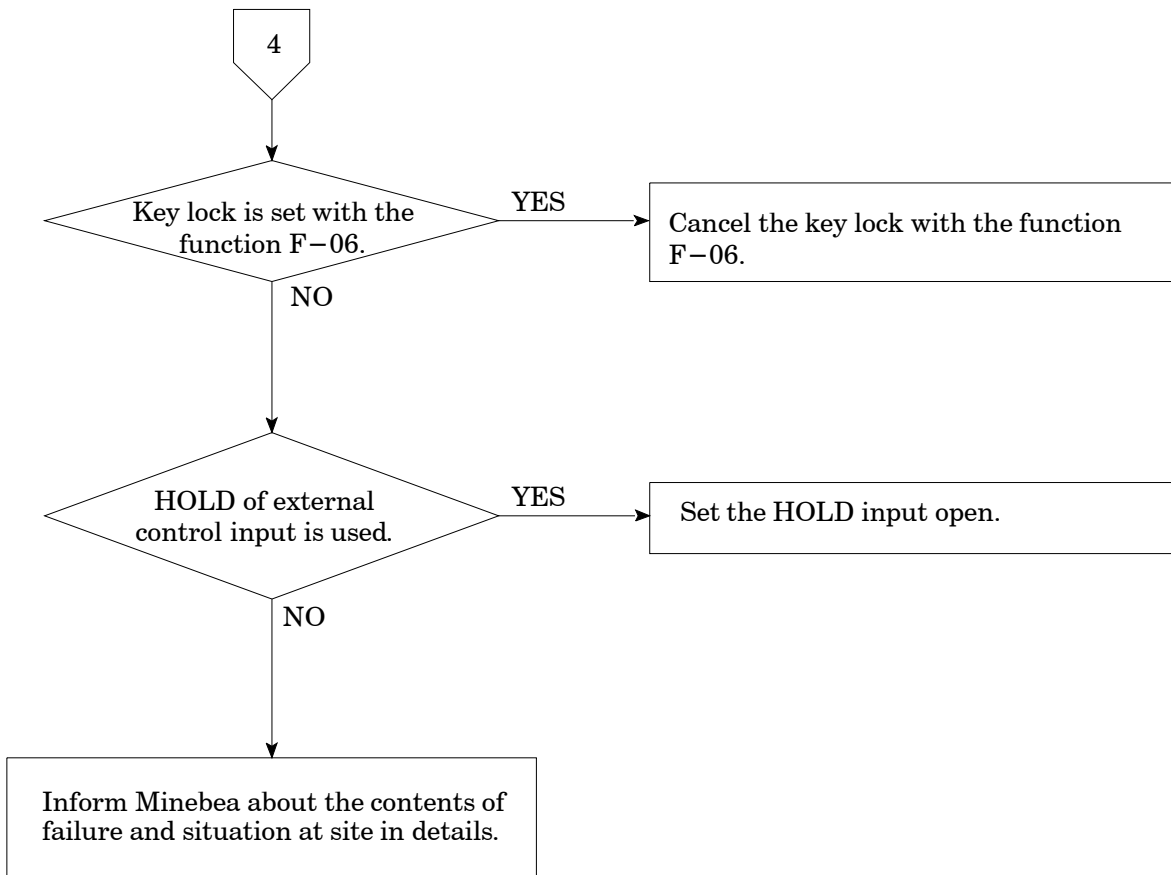

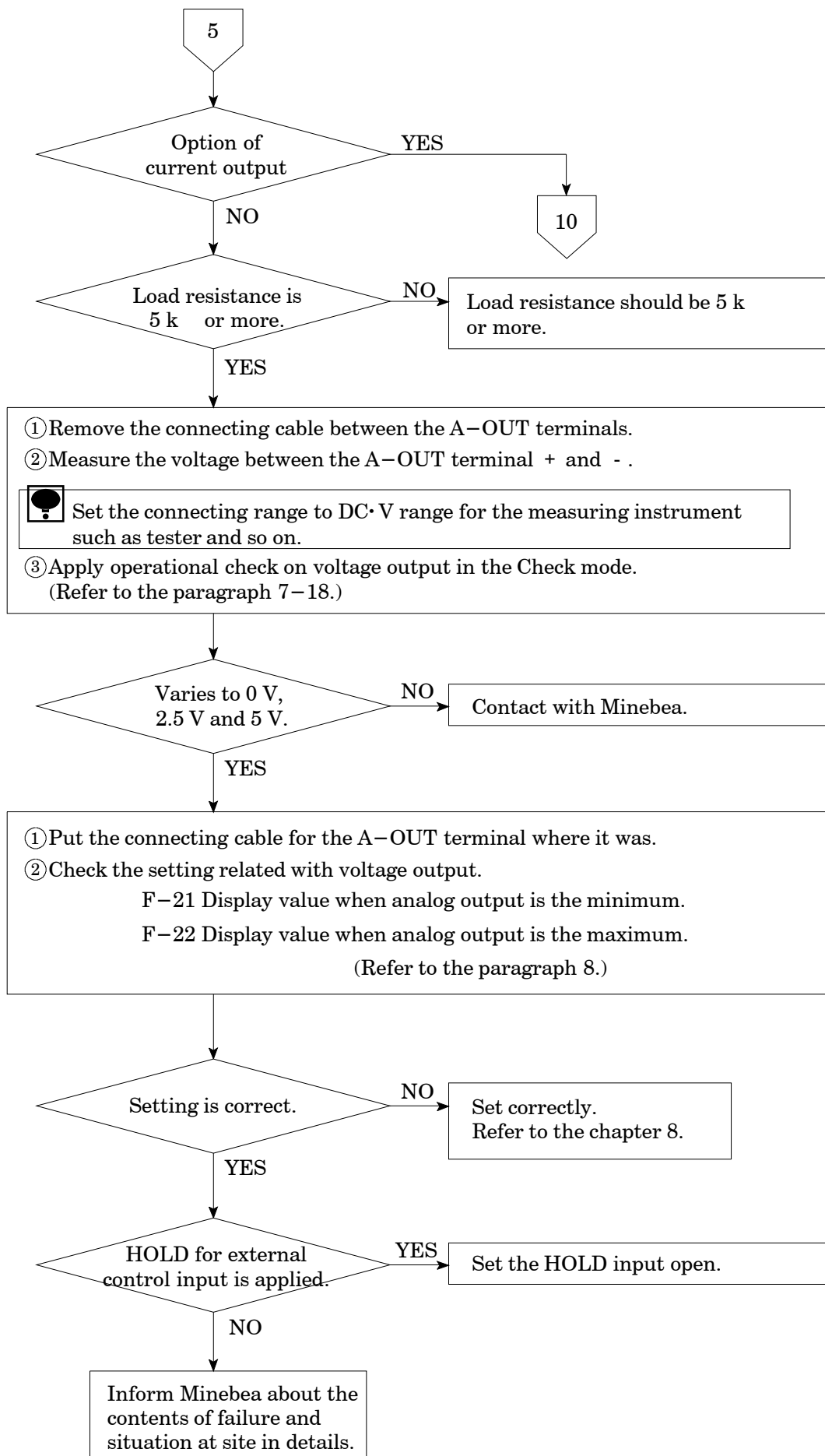

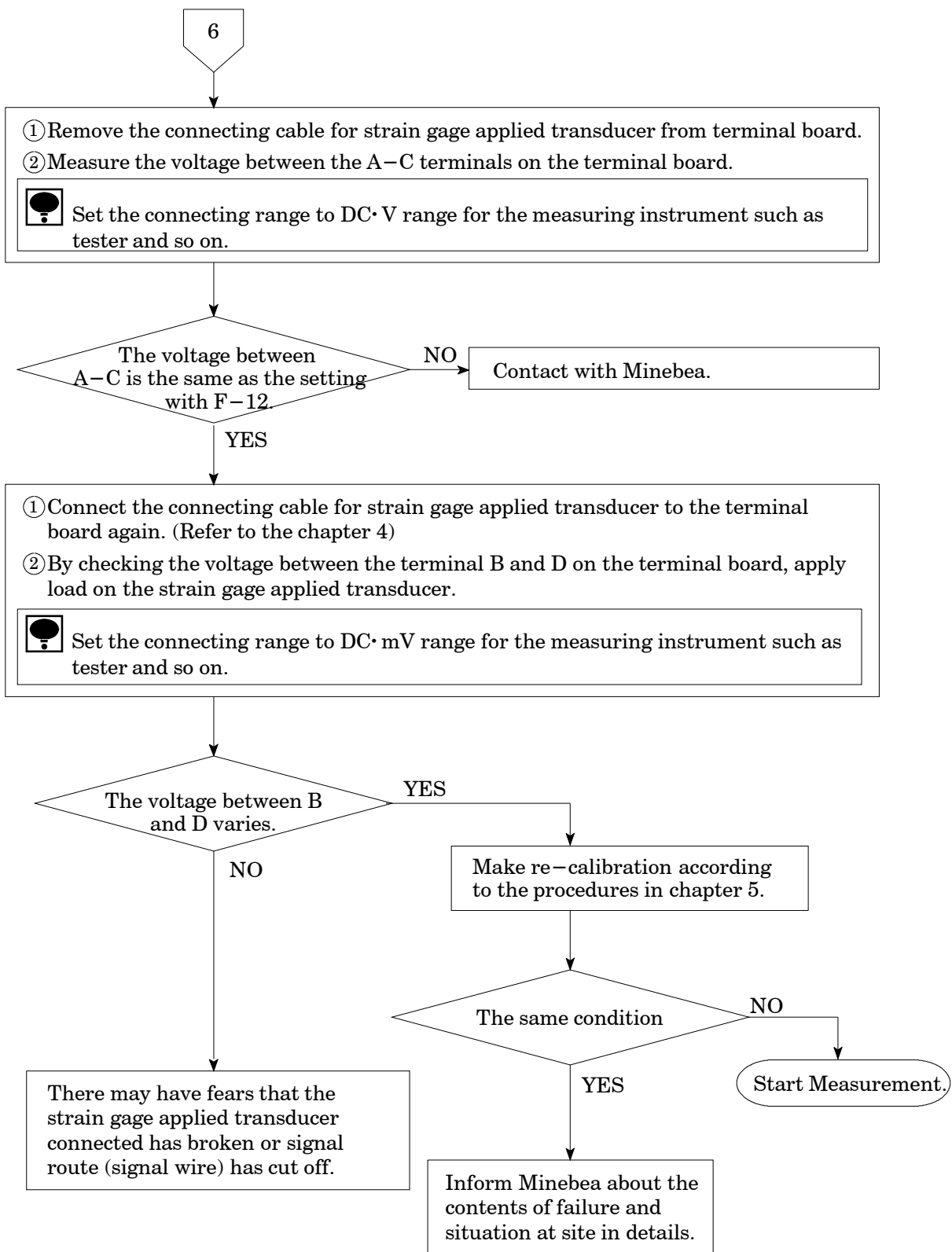

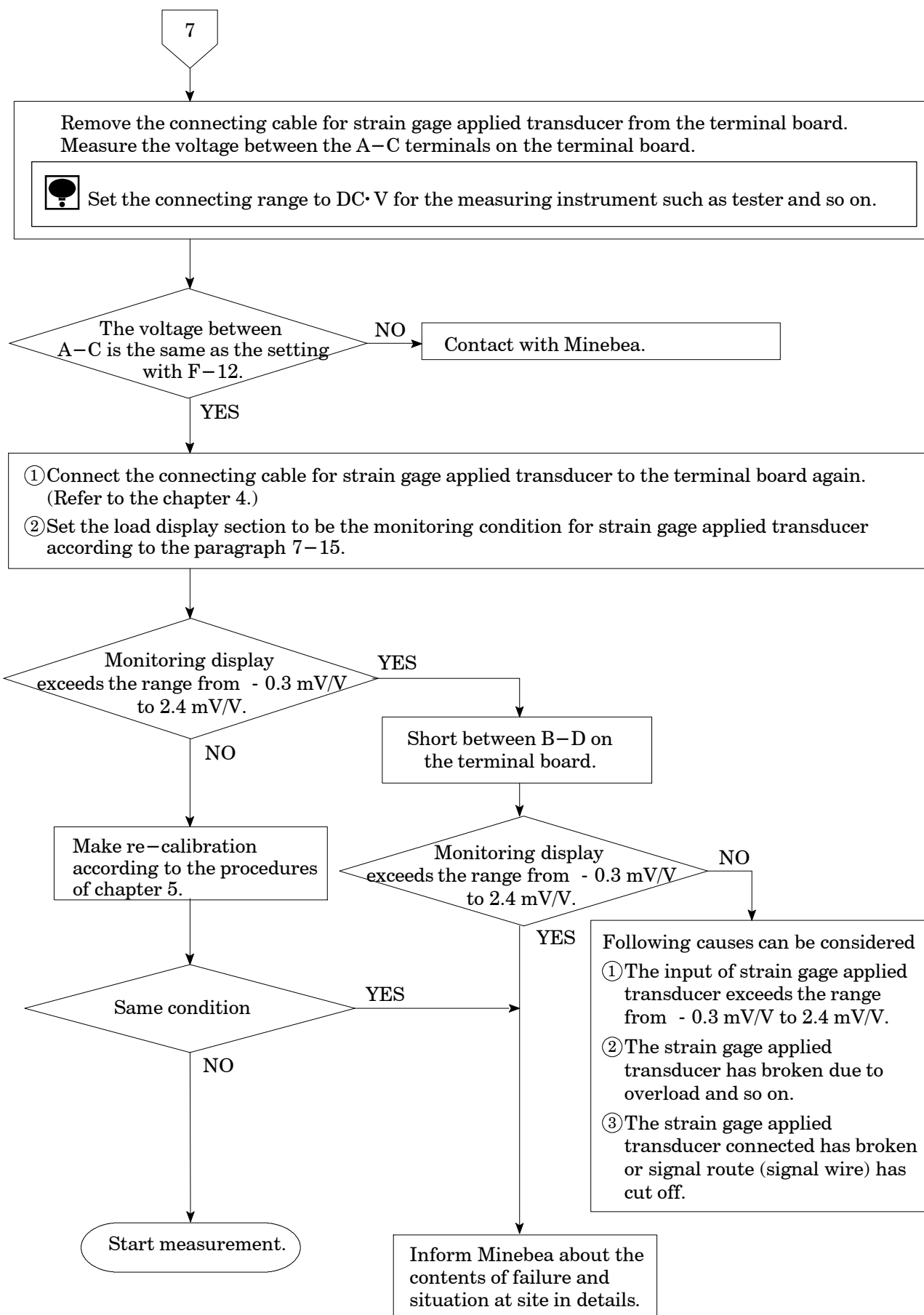

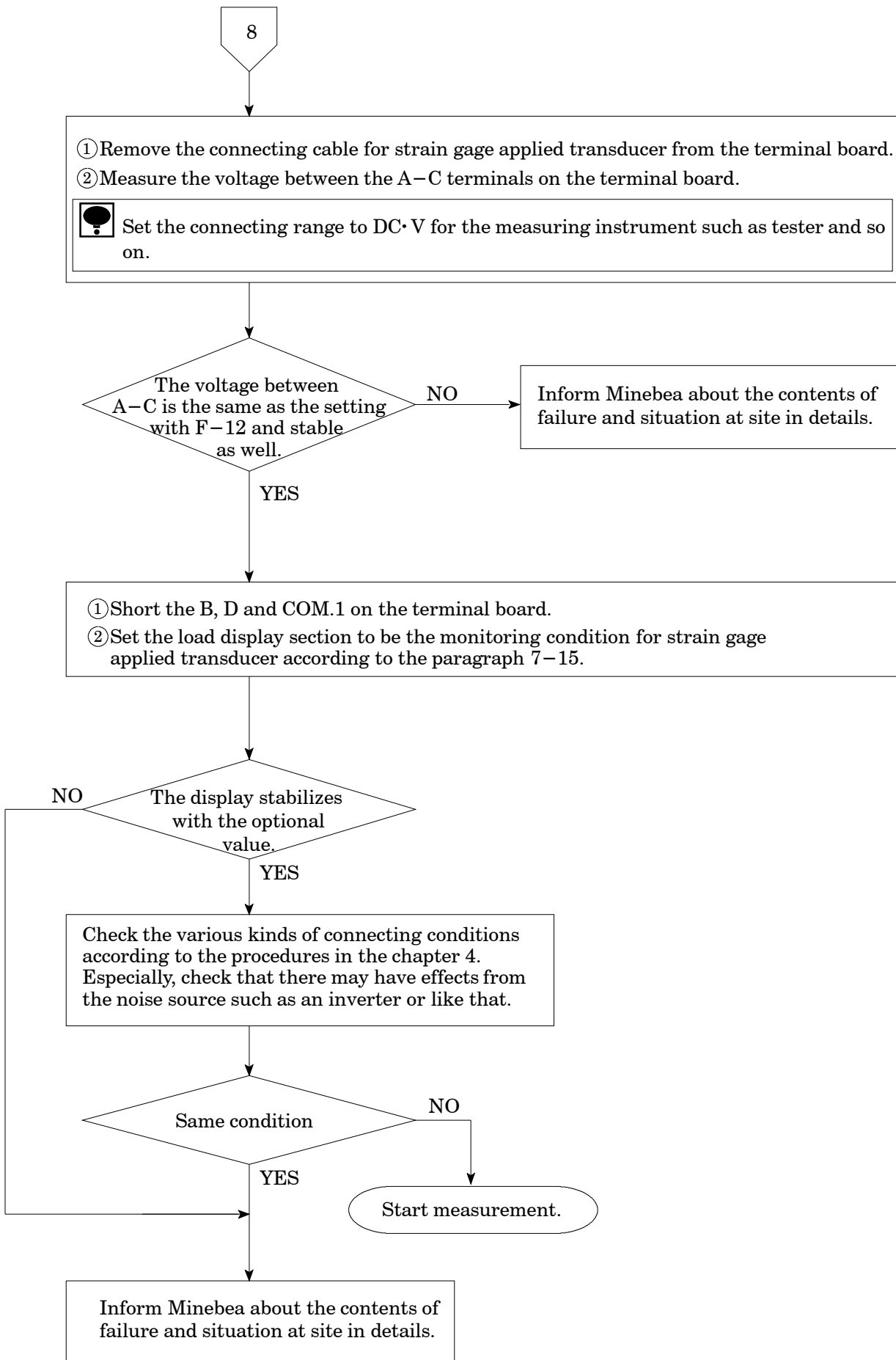

10-2. Optional check

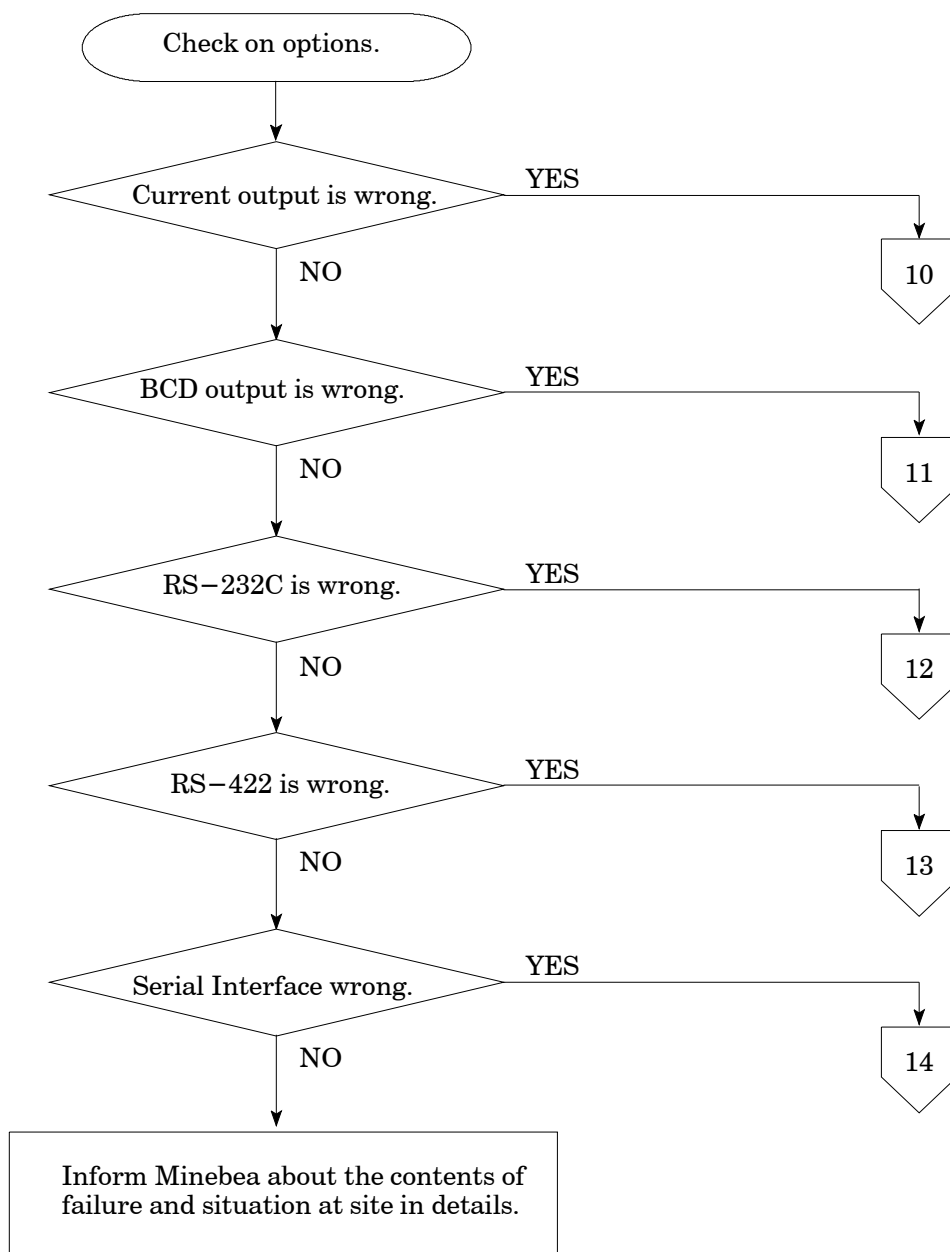

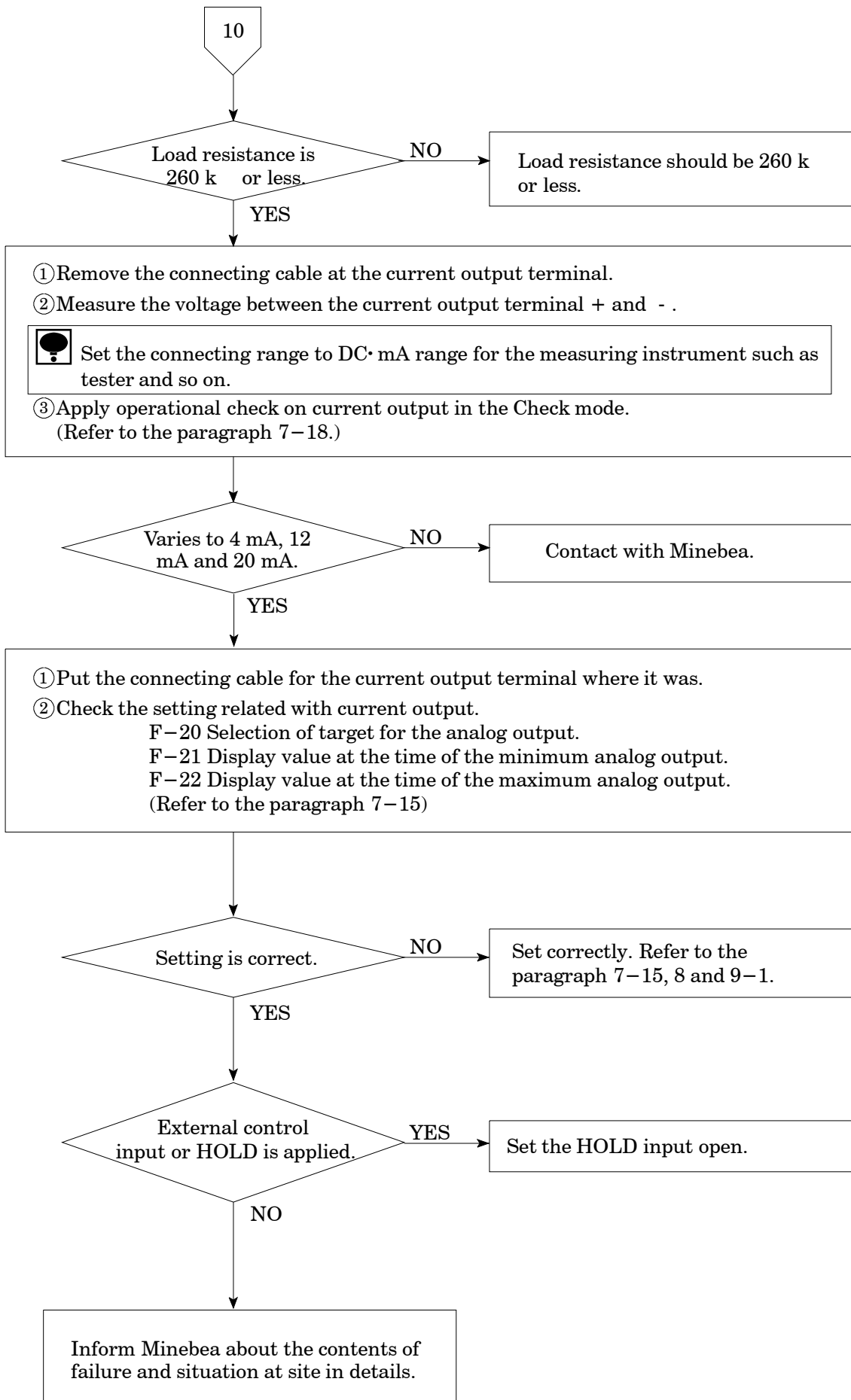

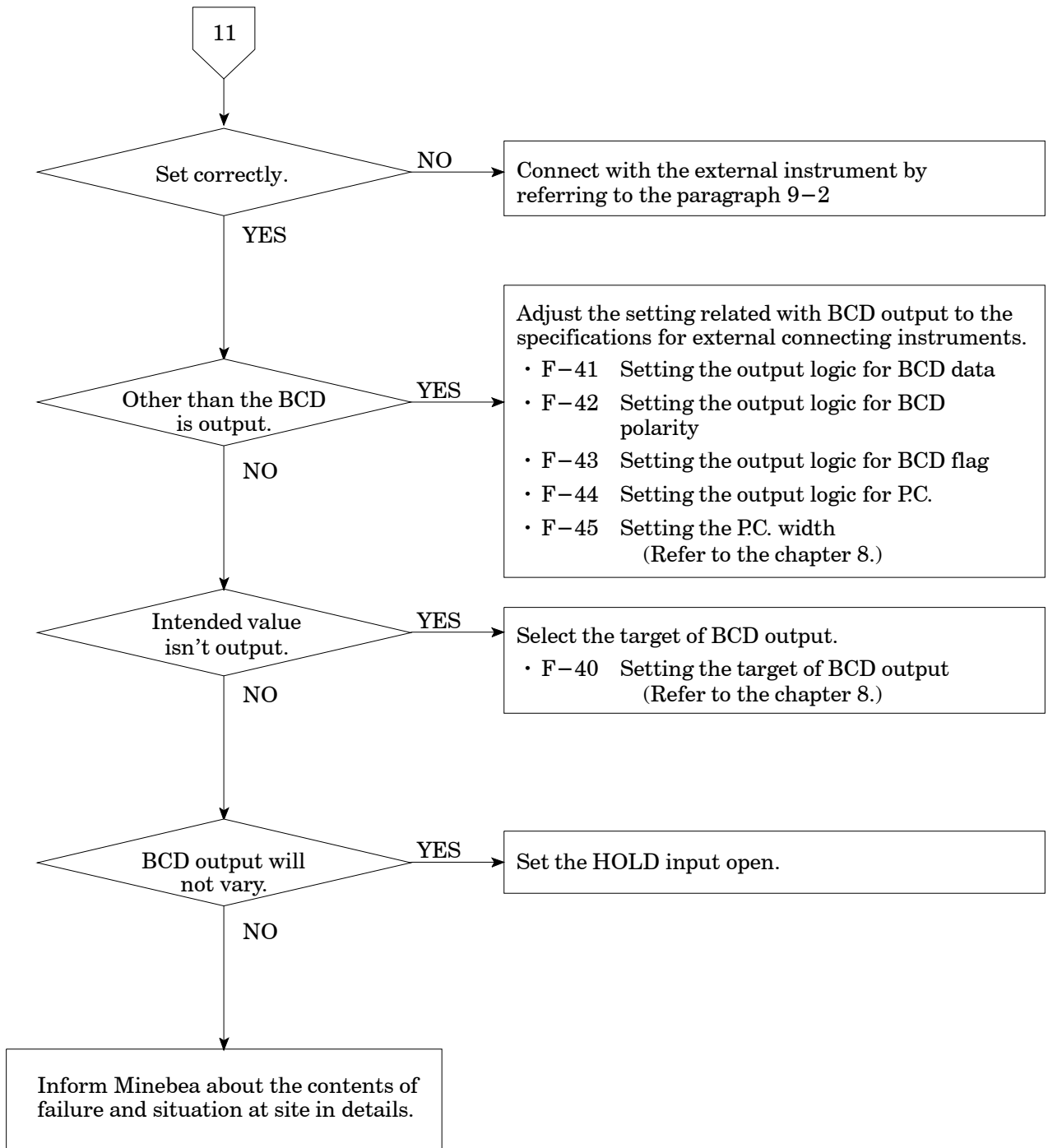

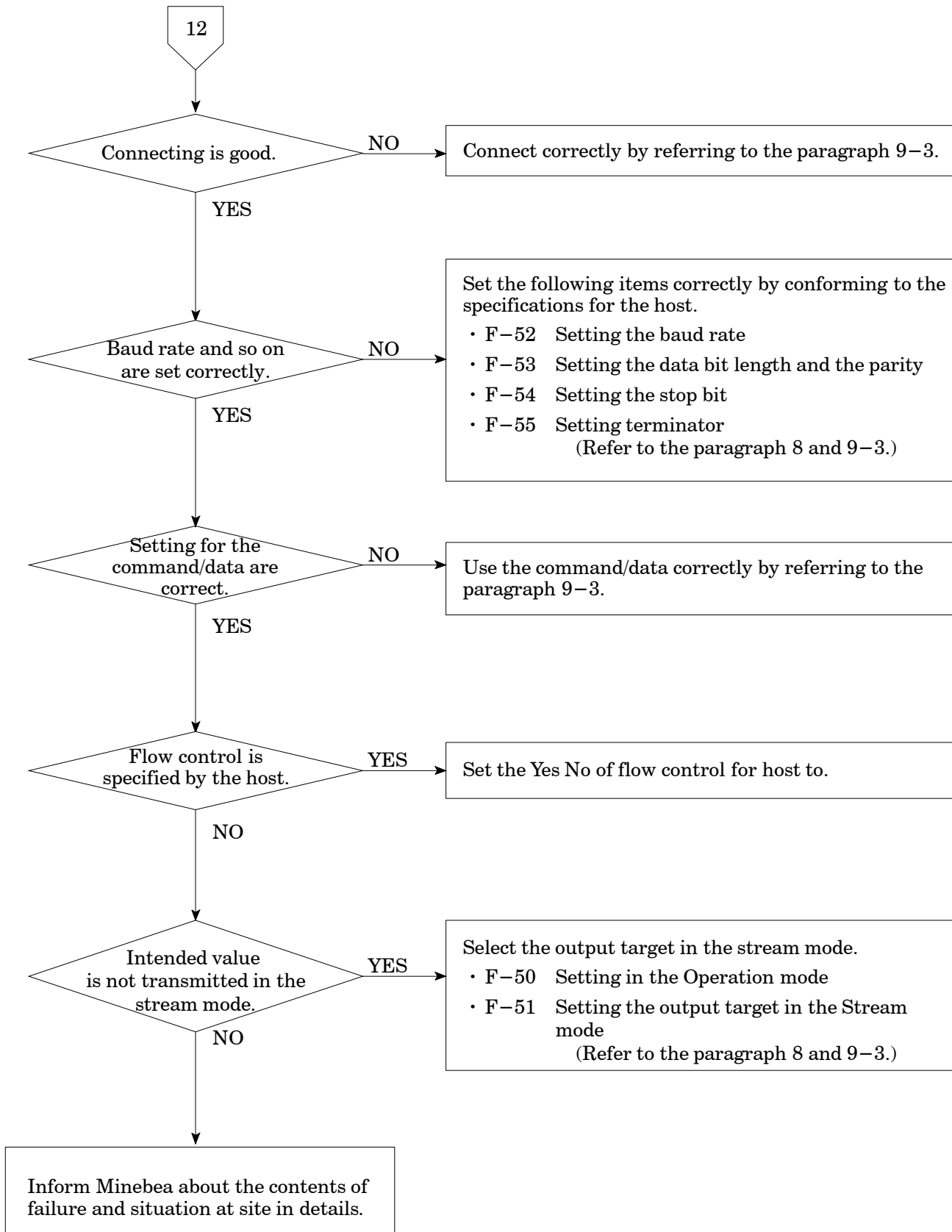

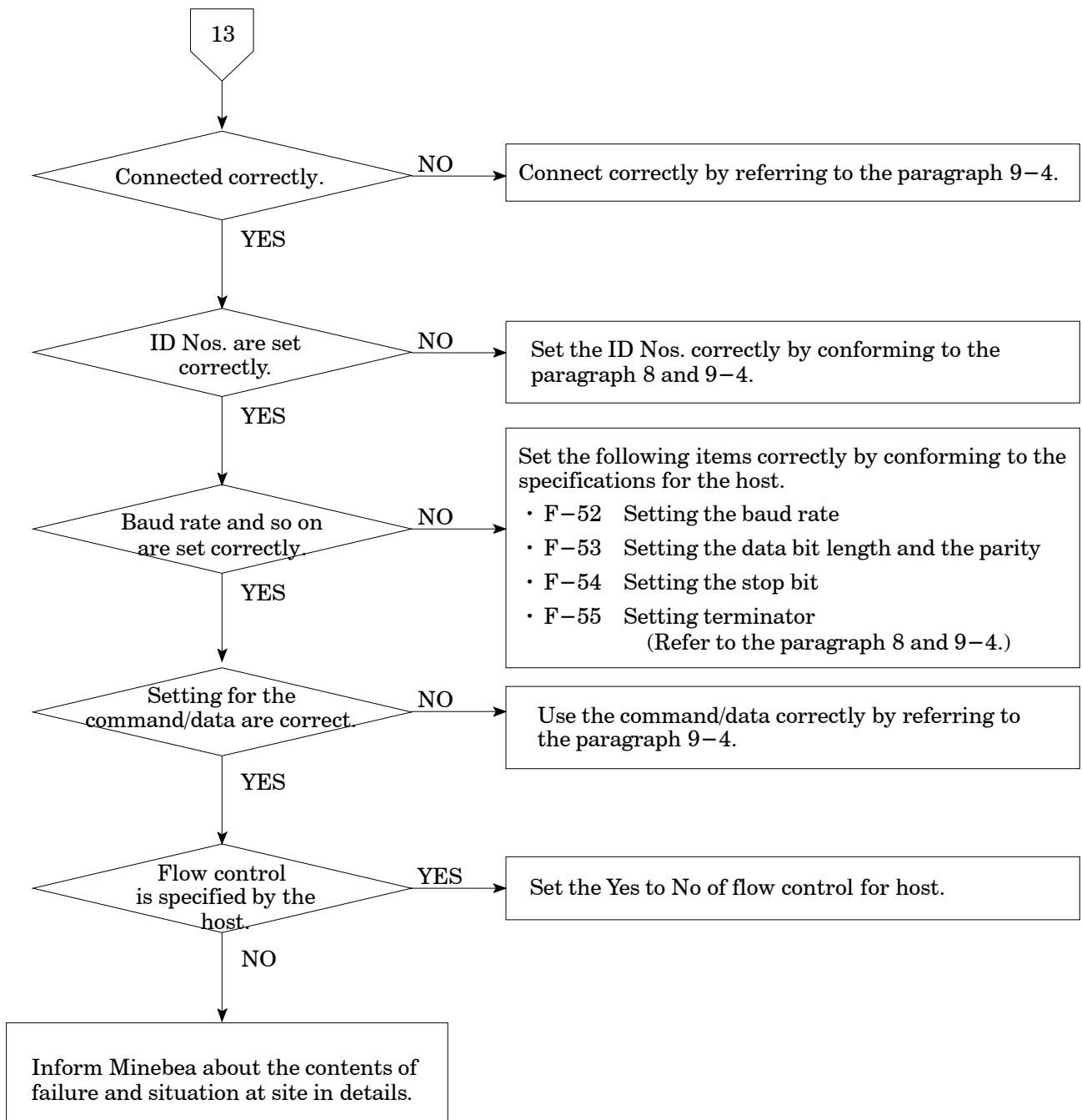

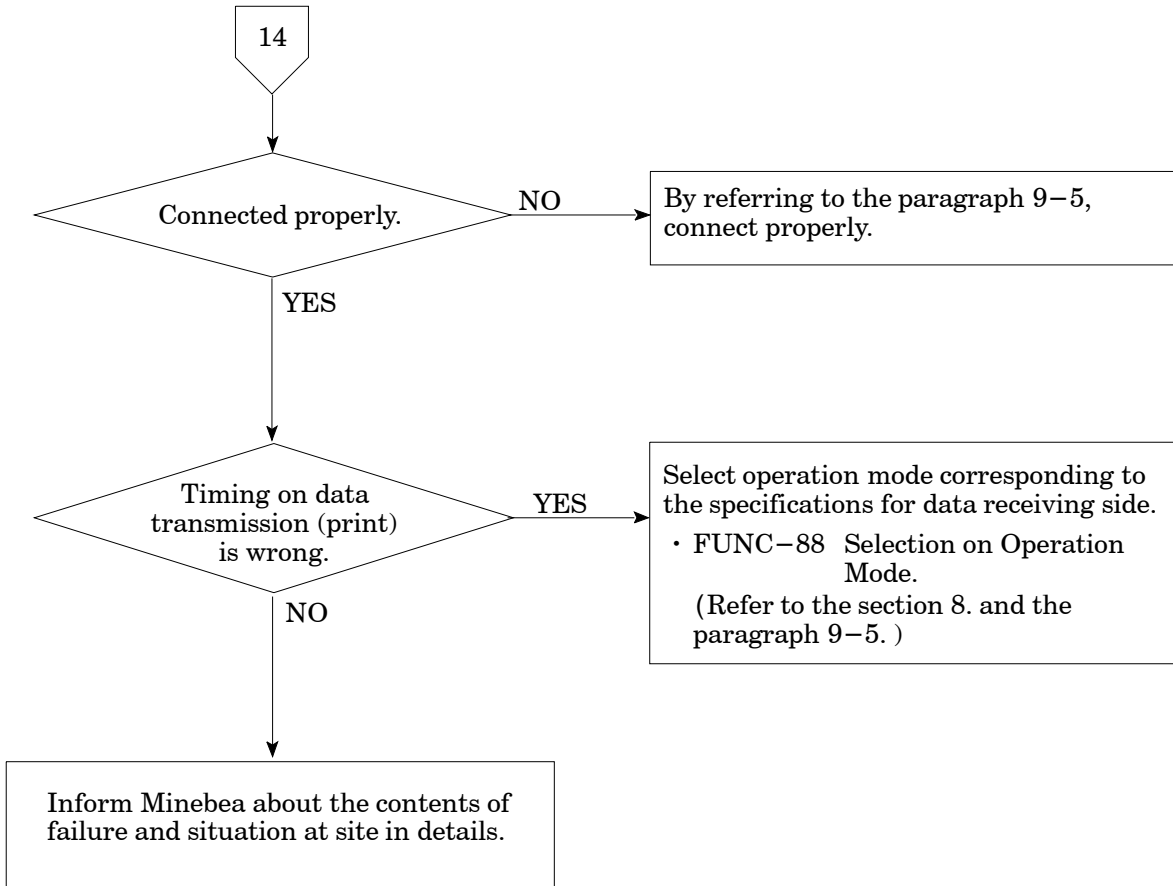

10-3. Error display

Error code	Contents of error	Remedy
ER-0	Zero set has executed with more than $\pm 10\%$ of the maximum display value.	Apply zero set after making it within $\pm 10\%$ of maximum display value.
	When CHECK is ON, zero setting is executed.	After CHECK is OFF, execute the zero setting.
ER-1	Setting mistake	Set correctly.
ER-2	Mistake in setting during calibration	Set correctly.
ER-3	A/D error	Turn off the power once and turn on it again. If the Error is still shown, contact with Minebea.
ER-4	Displays when the calibration(CCAL, ACAL, LCAL, TARE) is executed with the CHECK ON.	After setting the CHECK OFF, execute the calibration.
ER-5	At the time of fine adjustment on zero or span, it is shown when tare weight cancellation, zero set, and zero tracking and peak are ON. Displays while tare weight cancellation is ON when zero set is executed.	Set OFF while zero tracking is OFF. And set OFF while the peak is ON. Apply ZERO clear(F-98).
ER-6	When prohibiting the calibration is set, calibration or fine adjustment for analog is proceeded.	Remove the prohibition of calibration (F-97).
HOLD	Powered ON with the HOLD input is shorted.	Set the HOLD input open.
TE-L	Displays when the initial value at the time of calibration is less than -0.3 mV/V , or the total value with the initial load and the load equal to the maximum display value is less than -3.1 mV/V .	Adjust so that the initial load is within the range from -0.3 mV/V to 2.4 mV/V .
TE-H	Displays when the initial load is more than 2.4 mV/V , or the total value with the initial value and the load equal to the maximum display value exceeds 3.1 mV/V during calibration.	
SP-L	The value equal to the maximum display value at the time of calibration (LCAL) is less than 0.4 mV/V , or the difference between the initial value and the load equal to the maximum display value is less than 0.4 mV/V .	Adjust so that the value equal to the maximum display value is within the range from 0.4 mV/V to 3.1 mV/V .
SP-H	The value equal to the maximum display value at the time of calibration (LCAL) exceeds 3.1 mV/V , or the difference between the initial value and the load equal to the maximum display value exceeds 3.1 mV/V .	
ER-E	EEPROM error	Contact with Minebea.
ER-R	EEPROM error	
OL	Displays when 110% of the maximum display value is exceeded at the time of measurement or in calibration.	Set so that the load display will be within the range from -10% to 110% .
- OL	Displays when -10% of the maximum display value is exceeded at the time of measurement or in calibration.	
ER-W	RAM error	Contact with Minebea.

11. Specifications











11-1. Specifications for analog section

Bridge power supply	DC5 V \pm 0.25 V within 60 mA (Changeable to DC2.5 V)
Applicable transducers	Up to 4 pieces of strain gage applied transducers(350) can be connectable.
Input range	F.S. setting is available at the input range from 0.4 mV/V to \pm 3.1 mV/V.(When bridge power supply is DC5 V.)
Output range	DC + 5 V Load resistance is 5 k or more. F.S. setting is available in Function.
Output times	4 times/s, 20 times/s, 50 times/s or 100 times/s can be changeable. (Synchronous with display rate.)
Output resolution	Approx.1/10 000
Zero adjustment range	- 0.3 mV/V to 2.4 mV/V
Non-linearity	
Display	0.05 %F.S.
Output	0.05 %F.S.
Temperature coefficient	
Zero point	\pm 1 μ V/ (Input conversion, at the time of F.S. setting at the input from 0.5 mV/V to 3.1 mV/V)
Sensitivity	\pm 0.02 %F.S./ (Input conversion, at the time of F.S. setting at the input from 0.5 mV/V to 3.1 mV/V)
Input noise	\pm 1 μ Vp-p or less (With the default setting of digital filter and stabilized filter)
Input filter	1 Hz(At the "0" setting of the digital filter and the stabilized filter)
A/D sampling	20 times/s
CHECK	Approx.0.4 mV/V (Setting can be available at the approx. 0.2 mV/V interval within the range from approx.0.2 mV/V to 1.4 mV/V.) The extension cable should be applied to Minebea's standard cable CAB-502(4 cores) within the length of 30 m. Not applicable when the zener barrier is used.
Analog peak hold	Response speed : Corresponds to the characteristics of input filter. Accuracy : 0.1 %F.S. or less





11-2. Specifications for digital section

Load display	
Display range	- 9 999 to 99 999 (\times 2, \times 5 or \times 10 is available.)
Display increment	1 (2, 5 or 20 changeable)
Display	7 segment red LED, with 17 mm character's height
Over display	" - OL" displays at the time of minus(-) over, and "OL" displays at the time of plus (+) over.
Status display	, HOLD, CHECK, PEAK, A/Z
Judgement display	S1 and S2,
Display rate	4 times/s (20 times/s changeable.)
Decimal point display	Non, 10^1 , 10^2 , 10^3 or 10^4 changeable.

11-3. Front panel sheet key function

	Change of Function mode/ON and OFF of check value by the press of  key at the same time.
	S1 set value display/Carry on set value
	S2 set value display/Increment of set value/Zero set by the press of  key at the same time.
	Change of Track with Peak hold, Bottom hold or Peak bottom hold, /Status display, Tare weight cancellation is executed when  lights on. (Can be changed by the function.)
	Reset of peak value  During ON, the display is fixed to zero(0). /Status display, Tare weight cancellation clear is executed when  lights on. (Can be changed by the function.)
	Enter key/Shift key

11-4. External control function

ZERO	Same as the  +  key Above is effective once at the pulse input and the pulse width is 100 ms or more.
PEAK/TRACK / A/Z	Change of Track and Peak hold Tare weight cancellation is executed when  of status display lights on. (Can be changed by the function.) Open : Track Short : Peak hold
HOLD	Hold of Display, Comparative output, BCD output and Analog output
RESET / A/Z OFF	Same as the  key, reset condition can be made by short. Tare weight cancellation clear is executed when  of status display lights on. (Can be changed by the function.) Above are effective during the level input and short of more than 100 ms. When only the function A/Z and A/Z OFF, effective once at the pulse input and pulse width is 100 ms or more.

Equivalent circuit of external control input.

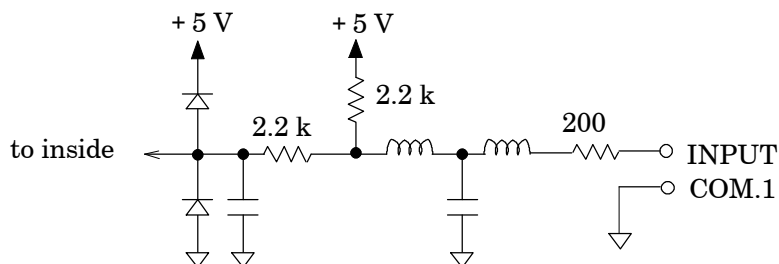

11-5. Comparator function

- Set value - 99 999 to 99 999
- Numbers of setting 2 points of S1 and S2.
- Set value for hysteresis data 0 to 99 digits
- Setting hysteresis time width 0 to 9.9 s
- Hysteresis direction Can be selected whichever “On delay” or “Off delay”.
- Conversion times for comparator
4 times/s or 20 times/s changeable.
(Synchronous with display rate.)
During the display of set value, process of measurement and also process of comparator are interrupted.

11-6. Contact output signal

- S1, S2 The contact operates when reached under/over the comparator set value.
- Contact specifications 1a contact
- | | |
|---------|---------------------------|
| AC125 V | 0.1 A (Resistance load) |
| DC30 V | 0.5 A (Resistance load) |

Equivalent circuit of contact output section

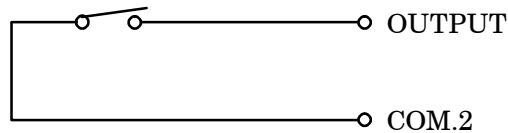

11-7. Various kinds of functions

- Zero tracking Stabilizes the variation of zero point within the fixed condition.
- Digital filter Stabilizes the data by the computing process through CPU.
- Stabilized filter Only when the load variation width is within the fixed value, this strengthens/stabilizes the digital filter.
- Change of target of HOLD With the combination of “Display”, “Comparative output”, “Analog output”, “BCD output(Option)”, target of HOLD can be made.
- Sheet key lock Prohibition of operation of optional key.
- Peak hold The maximum load value is always indicated.
- Change of target of analog output
The target of analog output can be changed either “TRACK value/Gross weight” and “PEAK/Net weight”.

11-8. General specifications

- Operating temperature/humidity range
- | | |
|-------------|------------------------------------|
| Temperature | - 10 to 50 |
| Humidity | Less than 85 %RH (Non condensing.) |
- Power supply
- | | |
|------------------------|---|
| Power supply voltage | AC100 V to AC240 V
(Allowable variable range AC85 V to AC264 V) |
| Power supply frequency | 50/60 Hz |
| Power consumption | Approx. 11 VA (Without option, at AC100 V)
Approx. 14 VA at max. (With options, at AC100 V to AC240 V) |
- Outline dimensions(W × H × D) 96 mm × 48 mm × 120 mm (Excludes protruding parts.)
- Weight Approx. 0.3 kg (Without any options.)

11-9. Standard specifications at the shipment

Bridge power supply	DC5 V
Span adjustment	2 000 display at the input of 0.5 mV/V.
The minimum scale	1
Analog output	0 V to 5. 000 V at the display of 0 to 2 000 display

11-10. Accessories

Instruction manual	1 piece
Midget fuse	1 piece (2 A)
Unit seal	1 piece
Panel mounting attachment	2 pieces
Panel mounting gasket	1 piece
BCD output plug	1 piece(Attached only when optional BCD output is installed.)

11-11. Options

11-11-1. Current output

- P/N CSD701B-P07
- Specifications
 - Output DC4 mA to 20 mA Load resistance at 260 or less
 - Non-linearity 0.05 %F.S.
 - Resolution Approx.1/10 000
 - Over range “ - OL” display at approx.DC0 mA and “OL” display at approx.DC24 mA.
Voltage output isn’t available when this option is installed.

11-11-2. BCD output

- P/N : CSD701B-P15
- Specifications
 - Output
 - BCD 5 digits Parallel output, with polarity(POL.) applied (Output ON with minus, and output OFF with plus.)
 - P.C.(Print command)
ON for a fixed time after conversion of BCD output is completed.
 - ERROR ON at the time of various errors are occurred.
 - OVR(over)
Above are open collector outputs. $V_{CE} = DC30 V$, $I_C = DC20 mA MAX$
Renewal of output can’t be made in other than the Measurement mode.
 - Input
 - BCD-ENABLE Compulsive OFF for the related output of BCD (Hi impedance)
The input is effective upon the short circuit at 100 ms or more.

11-11-3. RS-232C interface

- P/N CSD701B-P74
- Specifications
 - Baud rate : Select from 1 200, 2 400, 4 800, 9 600 and 19 200 bps
 - Data length : Select from 7 bits or 8 bits.
 - Parity bit : Select from Non, Even or Odd.
 - Stop bit : Select from 1 bit or 2 bits.
 - Terminator : Select from CR + LF or CR.
 - Communication method : Half-duplex

Synchronous method : Start–stop synchronous method
Communication data : ASCII code

11-11-4. RS-422 interface

- P/N CSD701B-P76
- Specifications
 - Baud rate : Select from 1 200, 2 400, 4 800, 9 600 and 19 200 bps.
 - Data length : Select from 7 bits and 8 bits.
 - Parity bit : Select from Non, Even or Odd.
 - Stop bit : Select from 1 bit or 2 bits.
 - Terminator : Select from CR + LF and CR.
 - Communication method : Half-duplex
 - Synchronous method : Start-stop synchronous method
 - Address : Select one among 0 to 31.
 - Communication data : ASCII code
 - Cable length : Approx. 1 km
 - No. of connections : 10 sets at max.
 - Termination : Built-in (Yes/No can be selected by the connection with terminal board.) With input/output monitor LED.
 - Change of RS-422/485 : Can be set in Function.

11-11-5. Serial interface

- P/N CSD701B-P77
- Specifications
 - 2-wire method serial interface
 - Baud rate : 600 bps
 - Data bit length : 8 bit
 - Parity bit : Odd
 - Stop bit : 1 bit
 - Communication data : Binary code, BCD
 - The communication stops, except for the measurement mode.

11-11-6. Power supply voltage

- P/N CSD701B-P66 (DC12 V)
 - Power supply DC12 V (DC10 V to DC15 V)
 - Power consumption Approx.3.6 W (at DC12 V)
- P/N CSD701B-P67 (DC24 V)
 - Power supply DC24 V (DC20 V to DC30 V)
 - Power consumption Approx.3.6 W (at DC24 V)

11-12. Outline dimensions

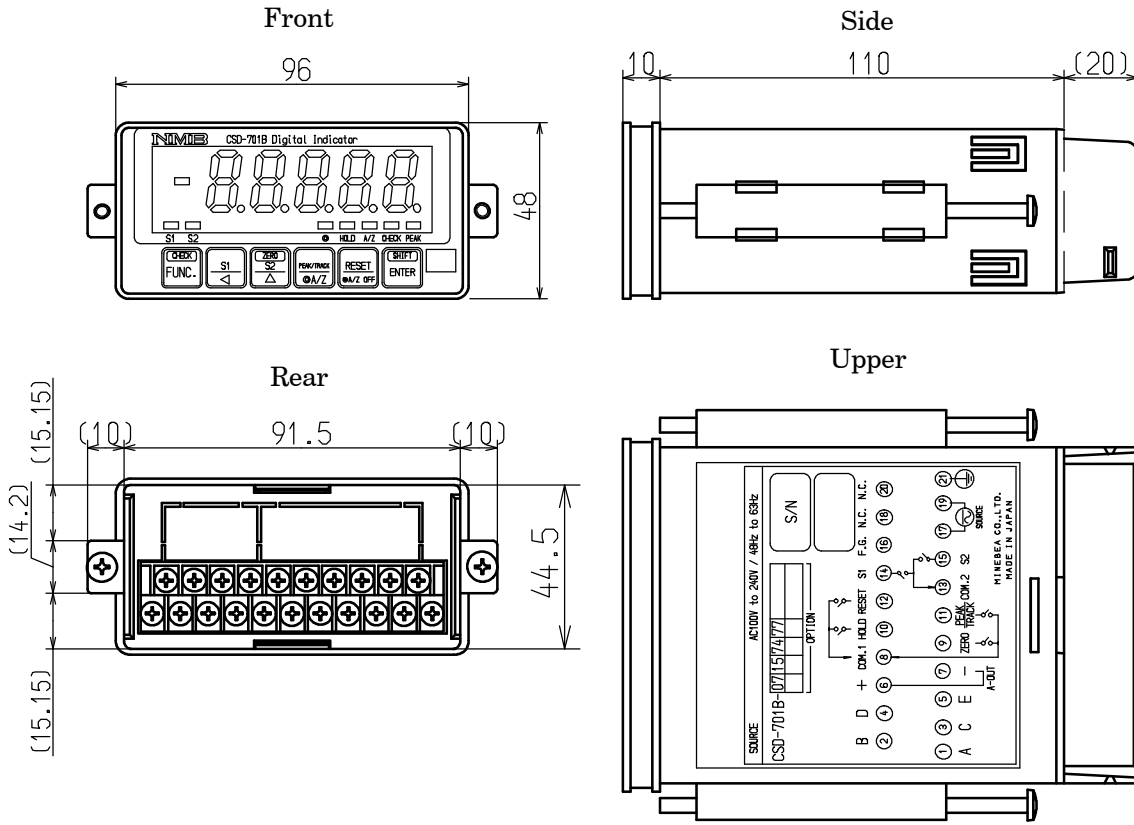

Panel cut size

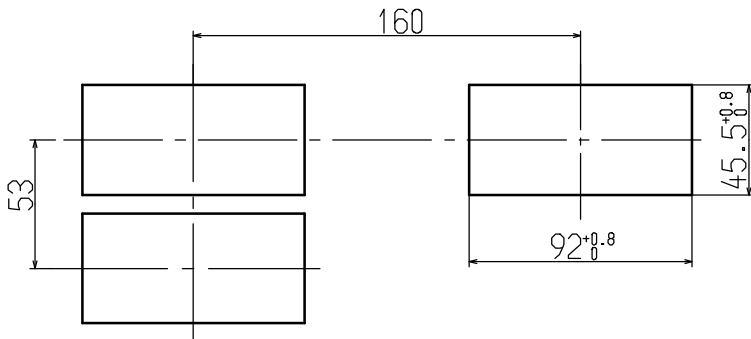

Unit : mm

12. Warranty

12-1. Warranty

- The instrument is covered by a warranty for a period of one year from the date of delivery.
- As for repairs and/or after service is required during the period of warranty, contact with Minebea's sales office or sales agent from which you have purchased.

12-2. Repair

Before asking repairs, make checks once again that the connection, setting and adjustment for the instrument have finished properly by referring to 9. Trouble shooting.

Especially, make checks whether the connections of sensors are disconnected or cut off.

After that, still there may be founds some defects in the instrument, contact with Minebea's sales office or sales agency from which you have purchased.

13. Appendix

13-1. Replacement of fuse

 **Warning** When installation method for the fuse is wrong and/or the capacity of installed fuse is inadequate, it causes an unexpected fault of the instrument.

- ① Turn OFF the power supply for the instrument.
- ② Hook A section of the case is opened in the direction of the arrow, and a rear panel is removed in the direction of the arrow.

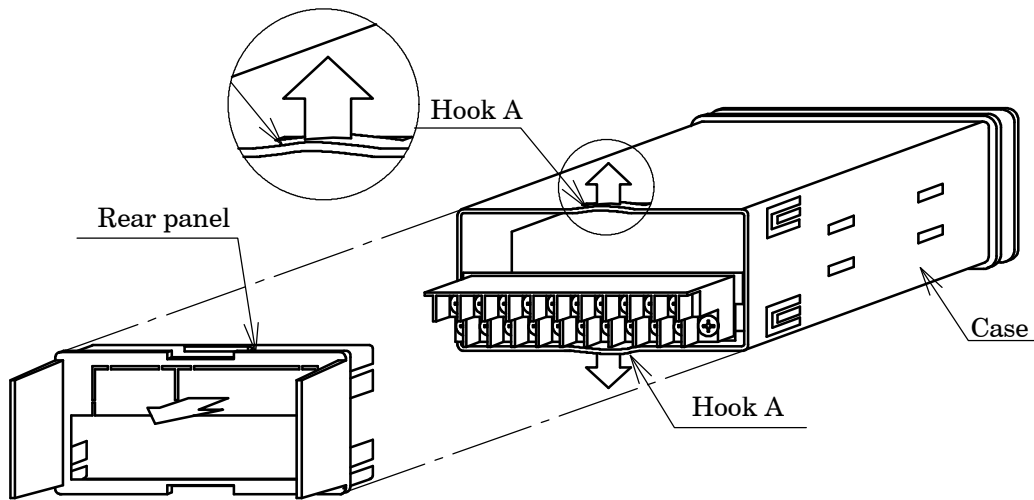

- ③ Hook B of the case is opened in the direction of the arrow, and the assembly board is drawn out in the direction of the arrow.

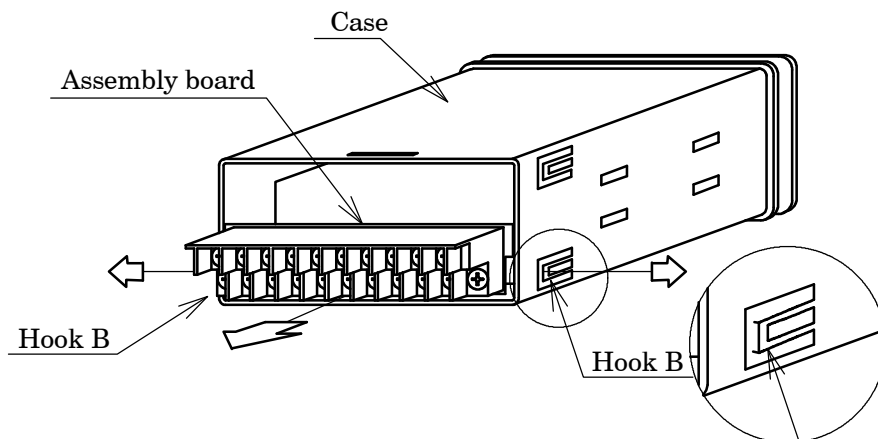

- ④ Replace the fuse installed on the POWER CARD.

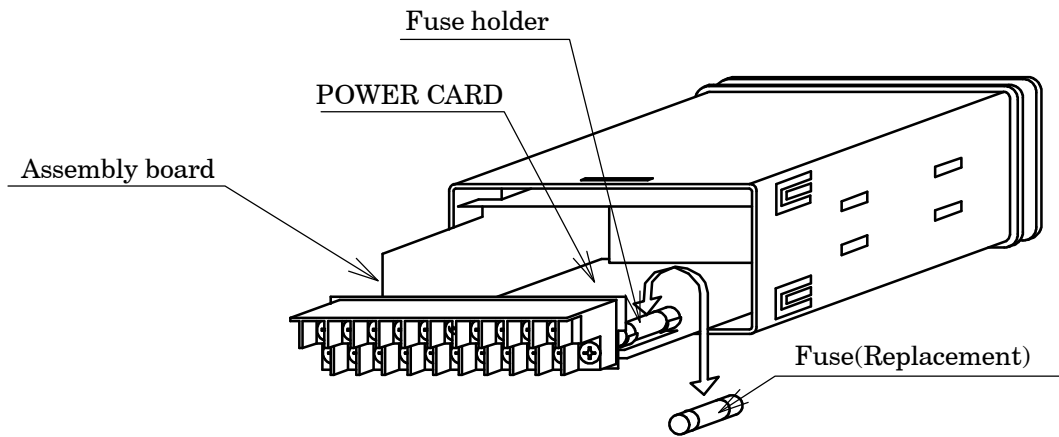

- ⑤ After the fuse is exchanged, the assembly board is inserted up to the place caught to hook B of the case.

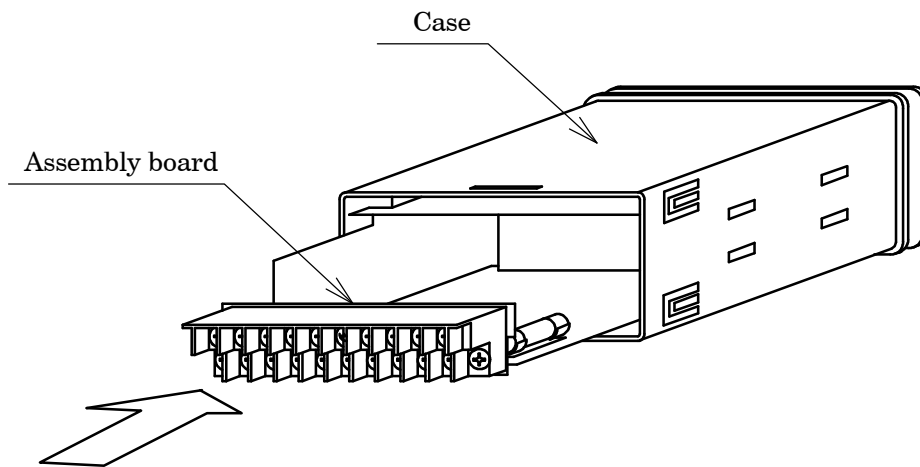

- ⑥ Please insert a rear panel up to the place caught to hook A of the case.

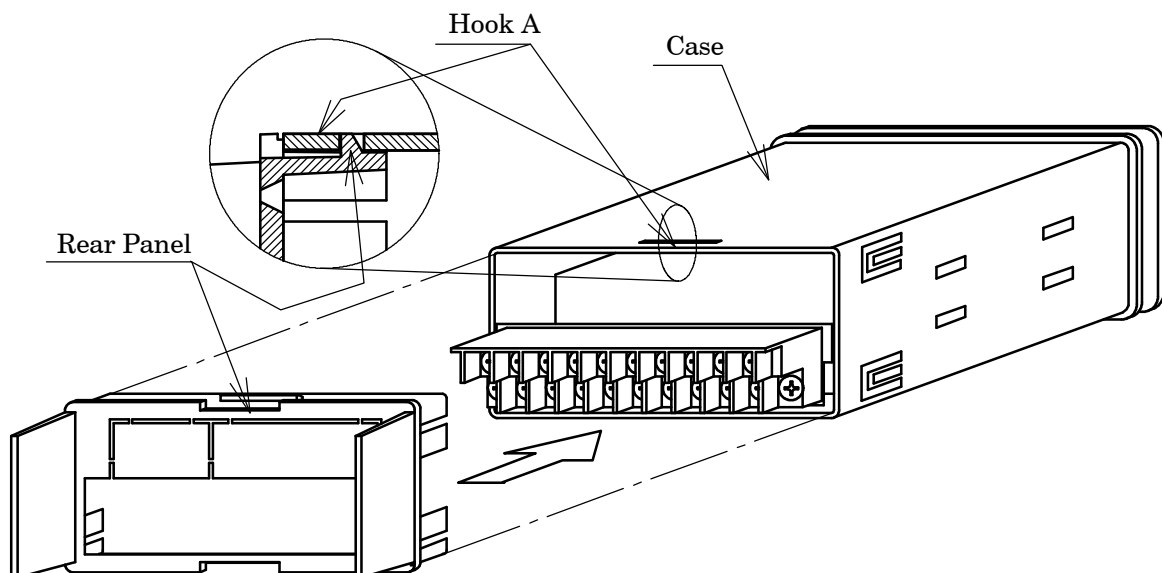

Warning

When the rear panel is not attached closely, you can't feel the click touch and also there may have the possibility that key operation is not made.

13-2. Character's pattern for display

The followings are the table to show the display pattern used at 7 segments display on the instrument.

0		D		Q	
1		E		R	
2		F		S	
3		G		T	
4		H		U	
5		I		V	
6		J		W	
7		K		X	
8		L		Y	
9		M		Z	
A		N		?	
B		O		!	
C		P		-	

13-3. Setting table for functions

Make use of them in case that the customer has changed setting for the function.

Function No.	Initial value	Customer's setting	Function No.	Initial value	Customer's setting
F-01	00000		F-42	00000	
F-03	00000		F-43	00000	
F-04	00004		F-44	00000	
F-06	00000		F-45	00000	
F-08	00000		F-50	00001	
F-09	00020		F-51	00000	
F-10	01111		F-52	00003	
F-11	00004		F-53	00021	
F-12	00000		F-54	00000	
F-15	00002		F-55	00001	
F-16	00020		F-56	00000	
F-17	00020		F-57	00000	
F-20	00000		F-70	00000	
F-21	00000		F-71	00001	
F-22	02000		F-88	00000	
F-30	00110		F-90	-	
F-31	00000		F-91	-	
F-32	00000		F-92	-	
F-34	00001		F-93	-	
F-35	00000		F-94	-	
F-36	00000		F-97	00000	
F-40	00000		F-98	-	
F-41	00000		F-99	-	

Memo

- The contents of this manual may subject to change without notice.

HEAD QUARTER : **MINEBEA CO., LTD.**

4106-73 Miyota, Miyota-machi, Kitasakugun, Nagano-ken 389-0293, Japan

☎0267-32-2200 FAX.0267-31-1350

Measuring Components Business Unit

FUJISAWA PLANT 1-1-1, Katase, Fujisawa-shi Kanagawa-ken, 251-8531 Japan

☎0466-22-7151 FAX.0466-22-1701

KARUIZAWA PLANT 4106-73 Miyota, Miyota-machi, Kitasakugun, Nagano-ken 389-0293, Japan

☎0267-31-1309 FAX.0267-31-1350

HOME PAGE ADDRESS **<http://www.minebea-mcd.com>**